

ASSEMBLY INSTRUCTIONS
COASTER FINE FURNITURE

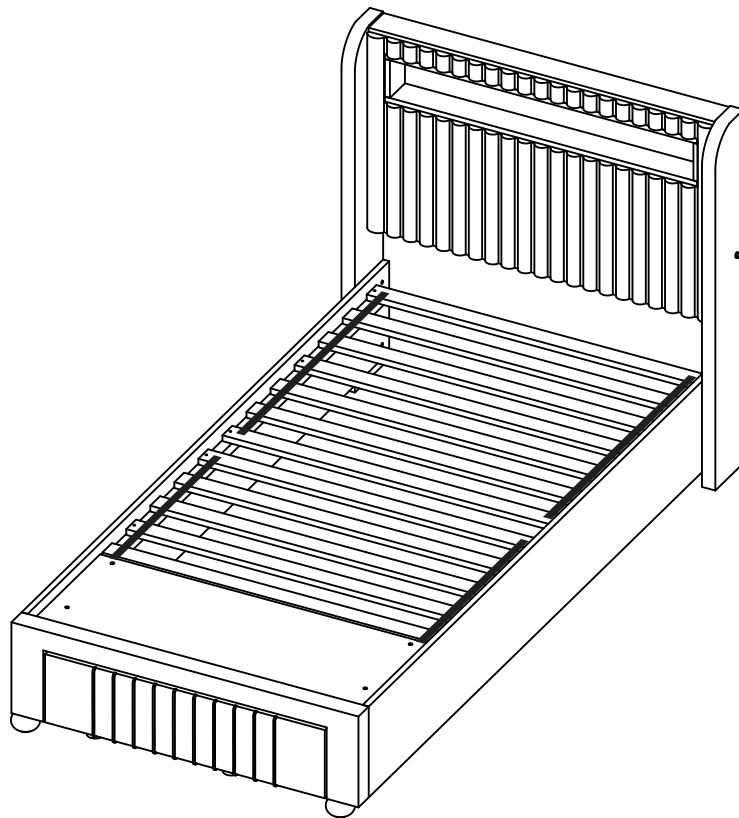

Fine Furniture for every stage of life

460550T(B1-B4)
Twin Storage Bed

ITEM: 460550T(B1-B4)



ASSEMBLY INSTRUCTIONS

ASSEMBLY TIPS :

1. Remove hardware from box and sort by size.
2. Please check to see that all hardware and parts are present prior to start of assembly.
3. Please follow attached instructions in the same sequence as numbered to assure fast & easy assembly.



WARNING !

1. Don't attempt to repair or modify parts that are broken or defective. Please contact the store immediately.
2. This product is for home use only and not intended for commercial establishments.



ASSEMBLY TIME

35 MINUTES

PARTS IDENTIFICATION

B1 (BOX 1)

A HEADBOARD PANEL

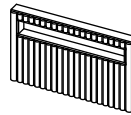

1PC

B CONCEAL PANEL

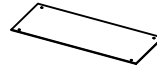

1PC

C ADAPTER



1PC

B2 (BOX 2)

D LEFT WING



1PC

E RIGHT WING



1PC

B3 (BOX 3)

F FOOTBOARD

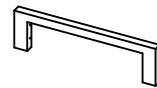

1PC

G BUN FOOT



2PCS

H ROLL SLATS (7PCS)



2SETS

I LEFT BED RAIL

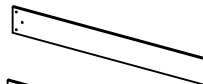

1PC

J RIGHT BED RAIL



1PC

B4 (BOX 4)

K FOOTBOARD DRAWER

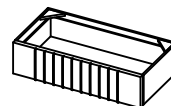

1PC

L DRAWER LEG



4PCS

NOTE:

Phillips head screw driver is required in the assembly process; however, manufacturer does not provide this item.

ITEM: 460550T(B1-B4)



ASSEMBLY INSTRUCTIONS

ASSEMBLY TIPS :

1. Remove hardware from box and sort by size.
2. Please check to see that all hardware and parts are present prior to start of assembly.
3. Please follow attached instructions in the same sequence as numbered to assure fast & easy assembly.











WARNING !

1. Don't attempt to repair or modify parts that are broken or defective. Please contact the store immediately.
2. This product is for home use only and not intended for commercial establishments.

HARDWARE IDENTIFICATION

Z-B3 (BOX 3) - HARDWARE PACK IS LOCATED IN 460550T(B3)

1	ALLEN WRENCH (Φ4 X 95mm- ZINC)		1PC
2	SHORT BOLT (Φ6 X 30mm - RBW)		4PCS
3	MEDIUM BOLT (Φ6 X 45mm - RBW)		8PCS
4	LONG BOLT (Φ6 X 60mm - RBW)		6PCS
5	FLAT HEAD SCREW (Φ4 X 32mm - RBW)		16PCS
6	LOCK WASHER (Φ6 - RBW)		16PCS
7	MEDIUM FLAT WASHER (Φ7 X 19mm X 2.0 - RBW)		16PCS
8	BIG FLAT WASHER (3/8 x 25 x 1.0 - RBW)		6PCS
9	PLASTIC DOWEL (Φ8 X 30MM)		6PCS

Z-B4 (BOX 4) - HARDWARE PACK IS LOCATED IN 460550T(B4)

10	MEDIUM BOLT (Φ6 X 45mm - RBW)		4PCS
11	LOCK WASHER (Φ6 - RBW)		4PCS
12	MEDIUM FLAT WASHER (Φ7 X 19mm X 2.0 - RBW)		4PCS

NOTE:

Phillips head screw driver is required in the assembly process; however, manufacturer does not provide this item.

ITEM: **460550T(B1-B4)**



ASSEMBLY INSTRUCTIONS

STEP 1

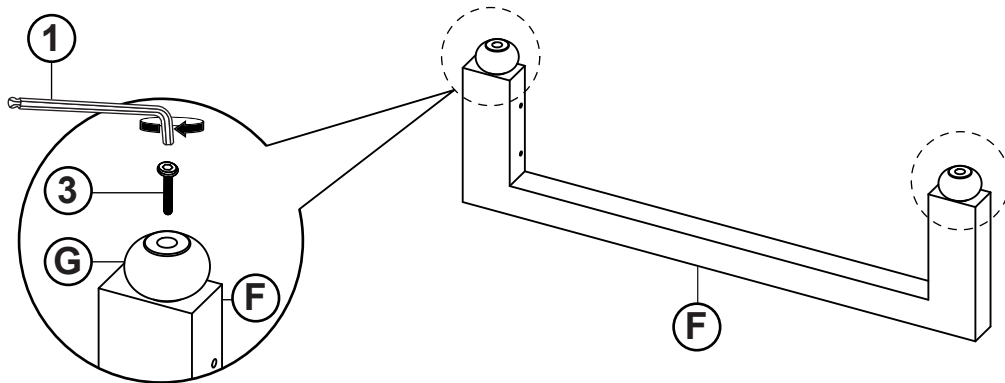

STEP 2

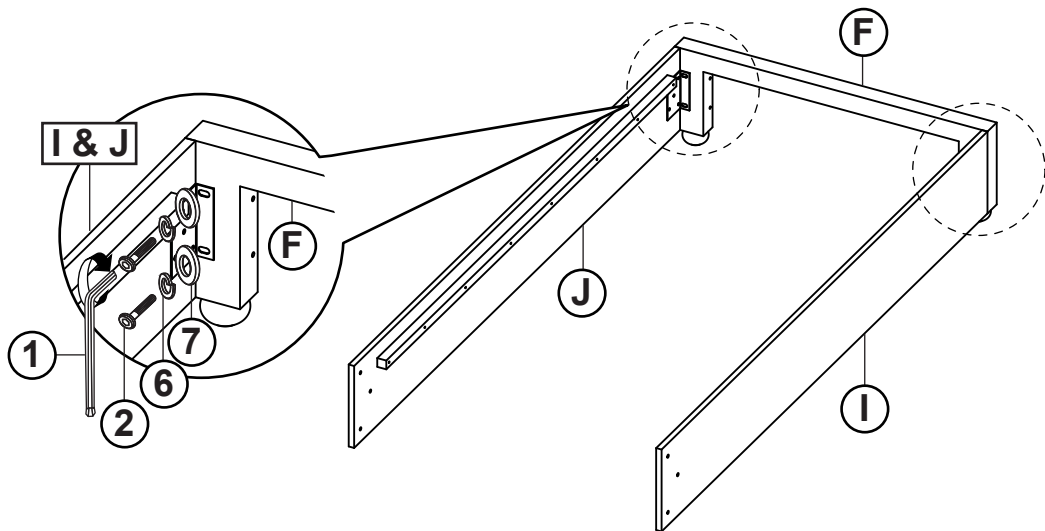

STEP 3

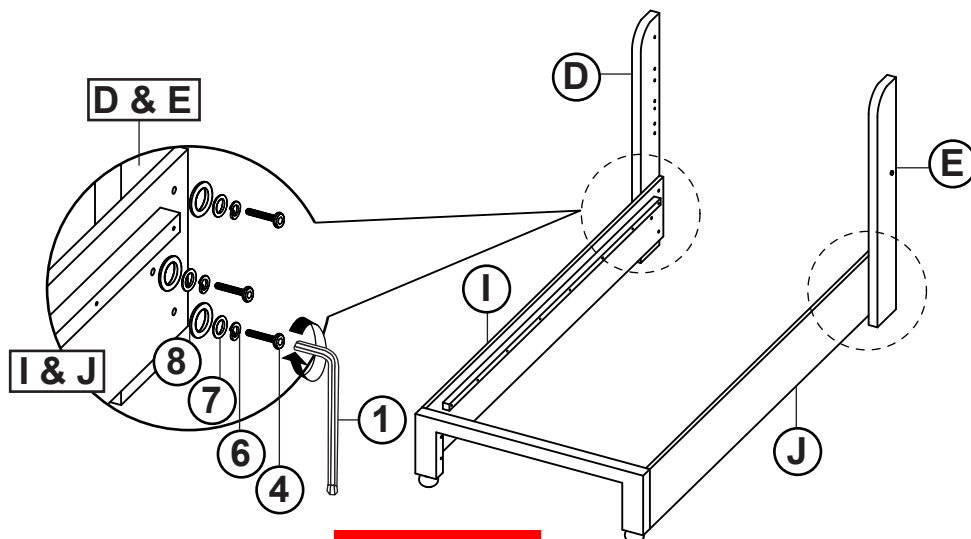

ITEM: **460550T(B1-B4)**



ASSEMBLY INSTRUCTIONS

STEP 4

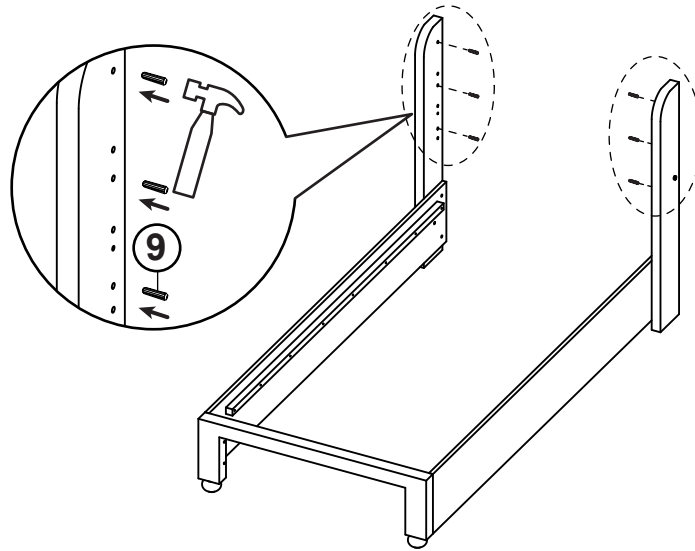

STEP 5

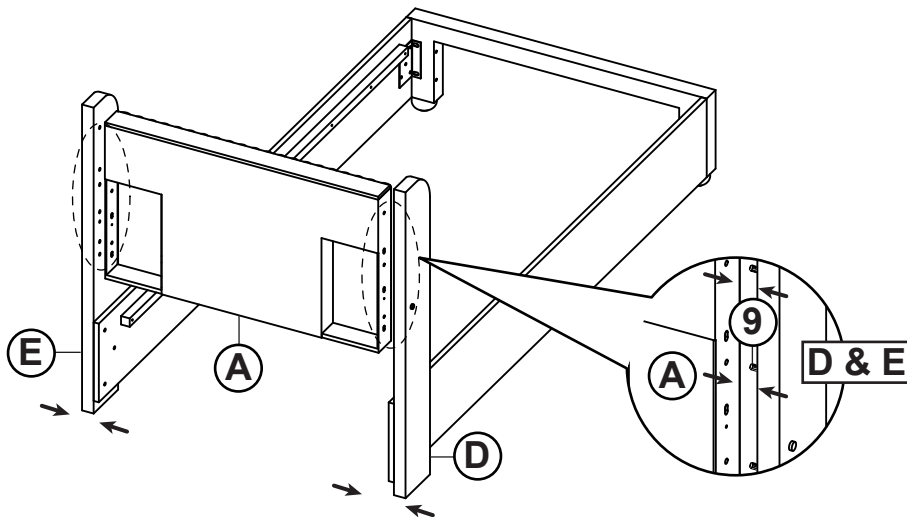

STEP 6

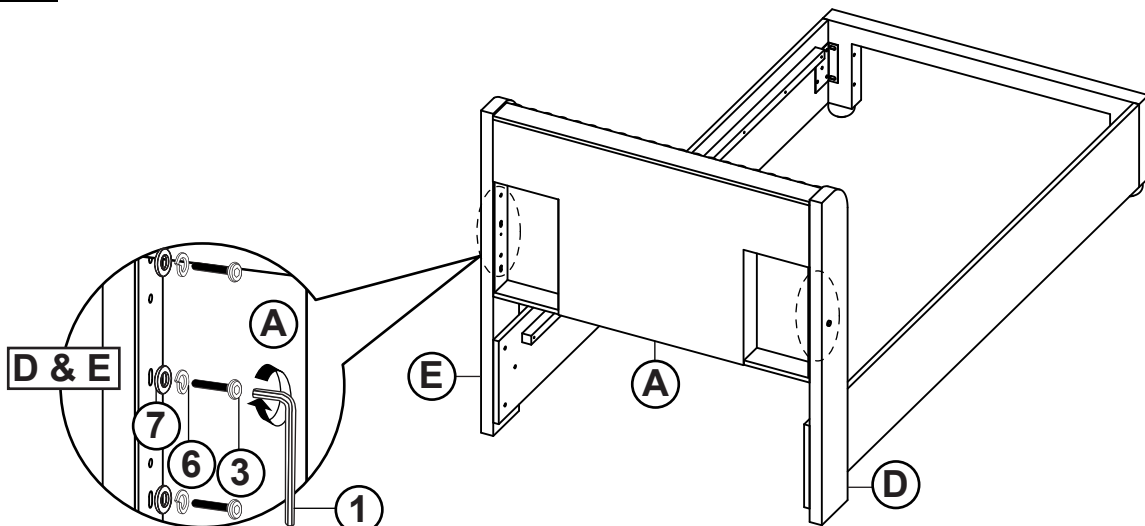

ITEM: **460550T(B1-B4)**



ASSEMBLY INSTRUCTIONS

STEP 7

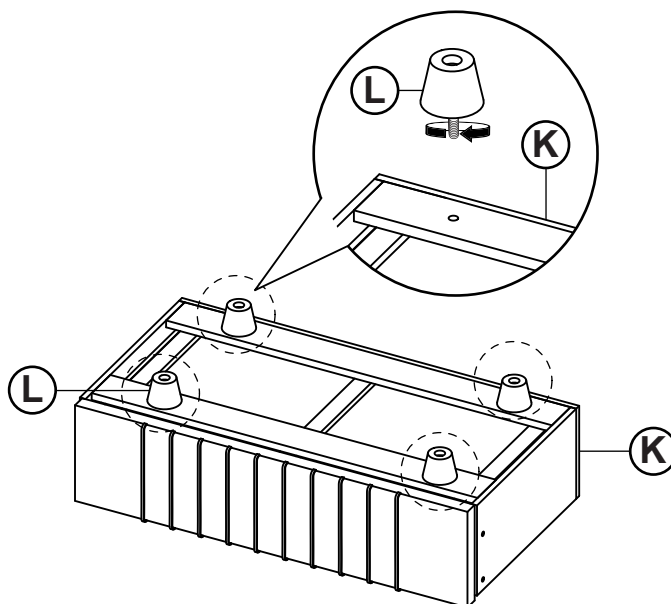

STEP 8

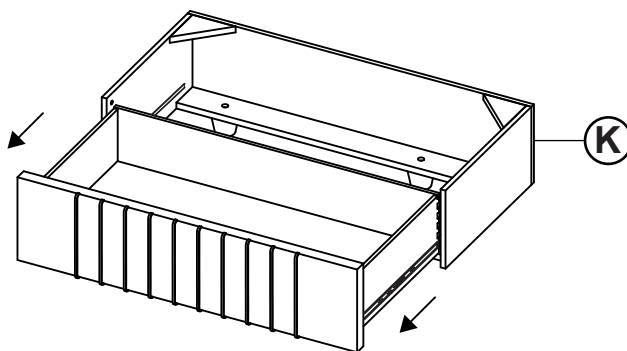

STEP 9

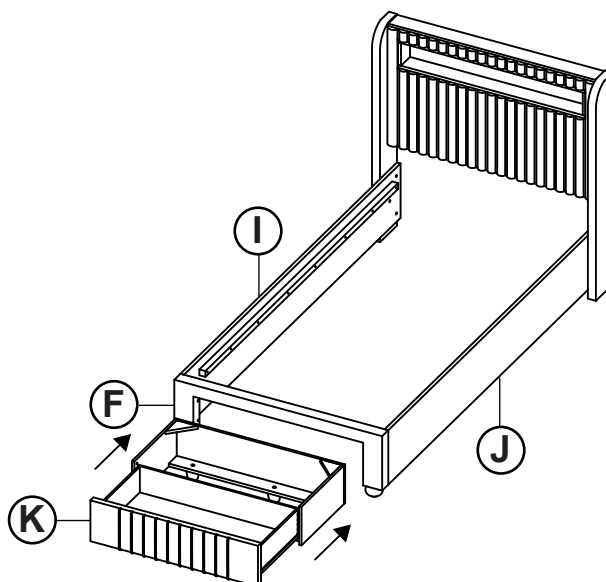

ITEM: 460550T(B1-B4)



ASSEMBLY INSTRUCTIONS

STEP 10

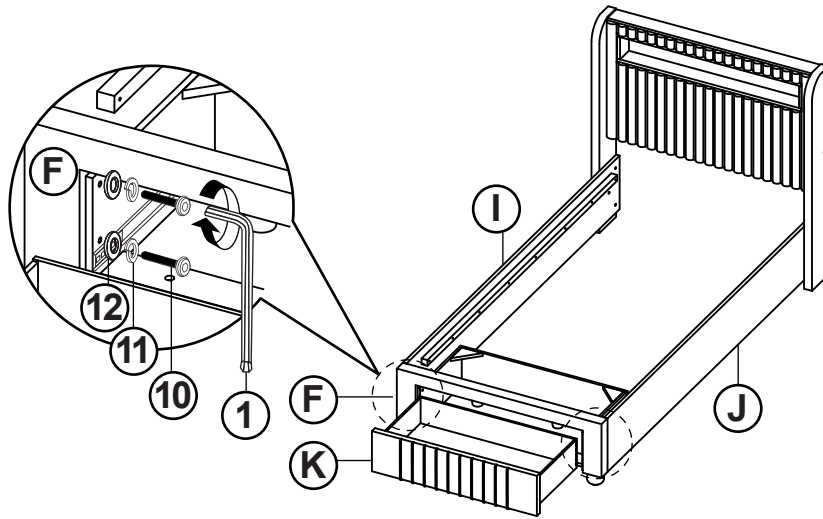

STEP 11

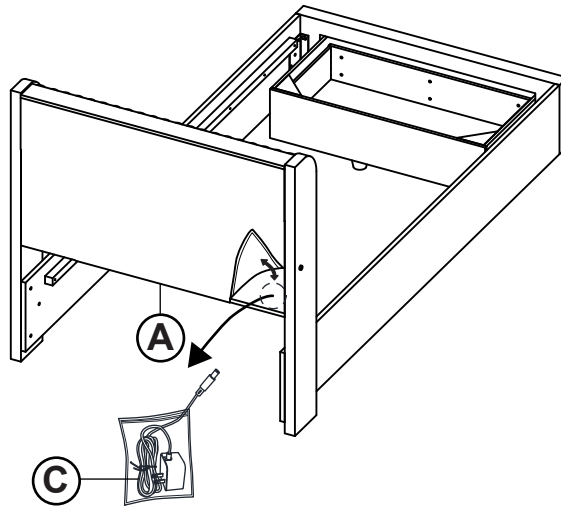

STEP 12

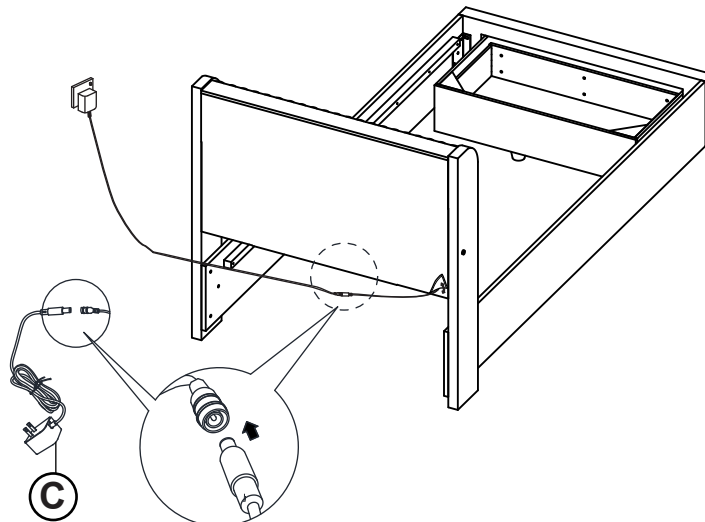

ITEM: 460550T(B1-B4)



ASSEMBLY INSTRUCTIONS

STEP 13

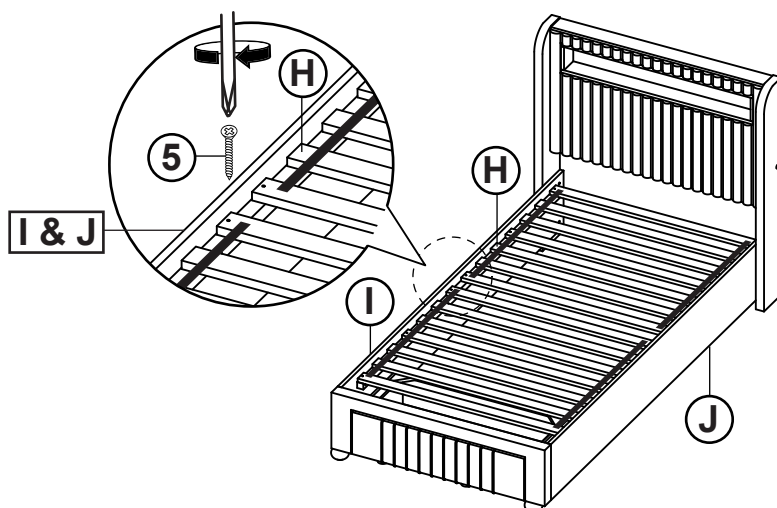

STEP 14

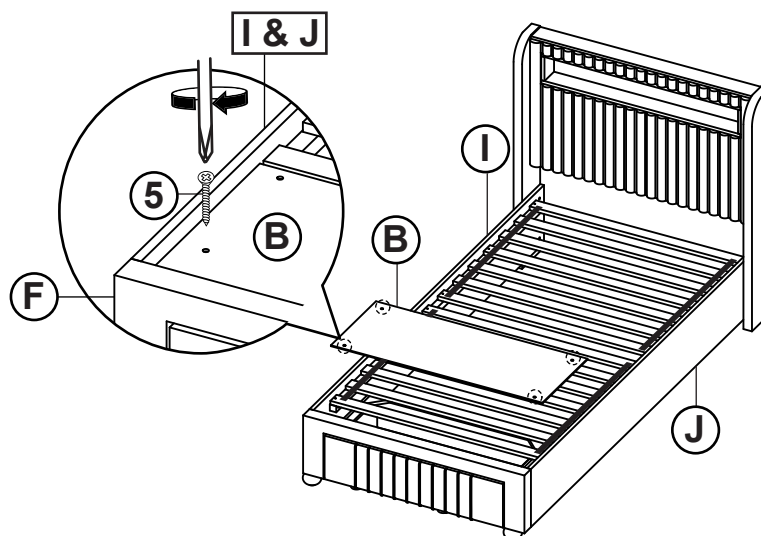

STEP 15 **COMPLETE**

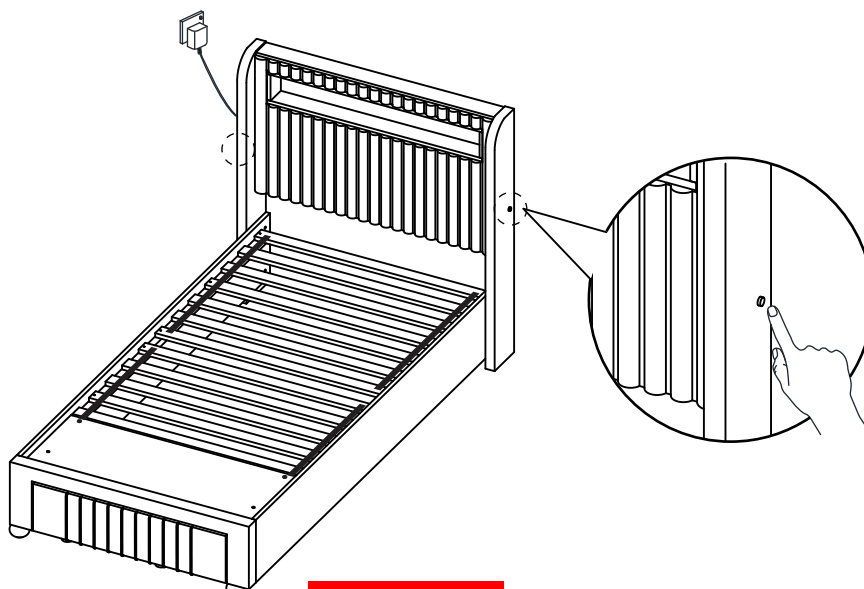

ITEM: **460550T(B1-B4)**



Inner Size : 39.25"W x 76.00"D

Inner Size of Drawer : 30.50"W x 14.50"D x 5.25"H x 0.50"T

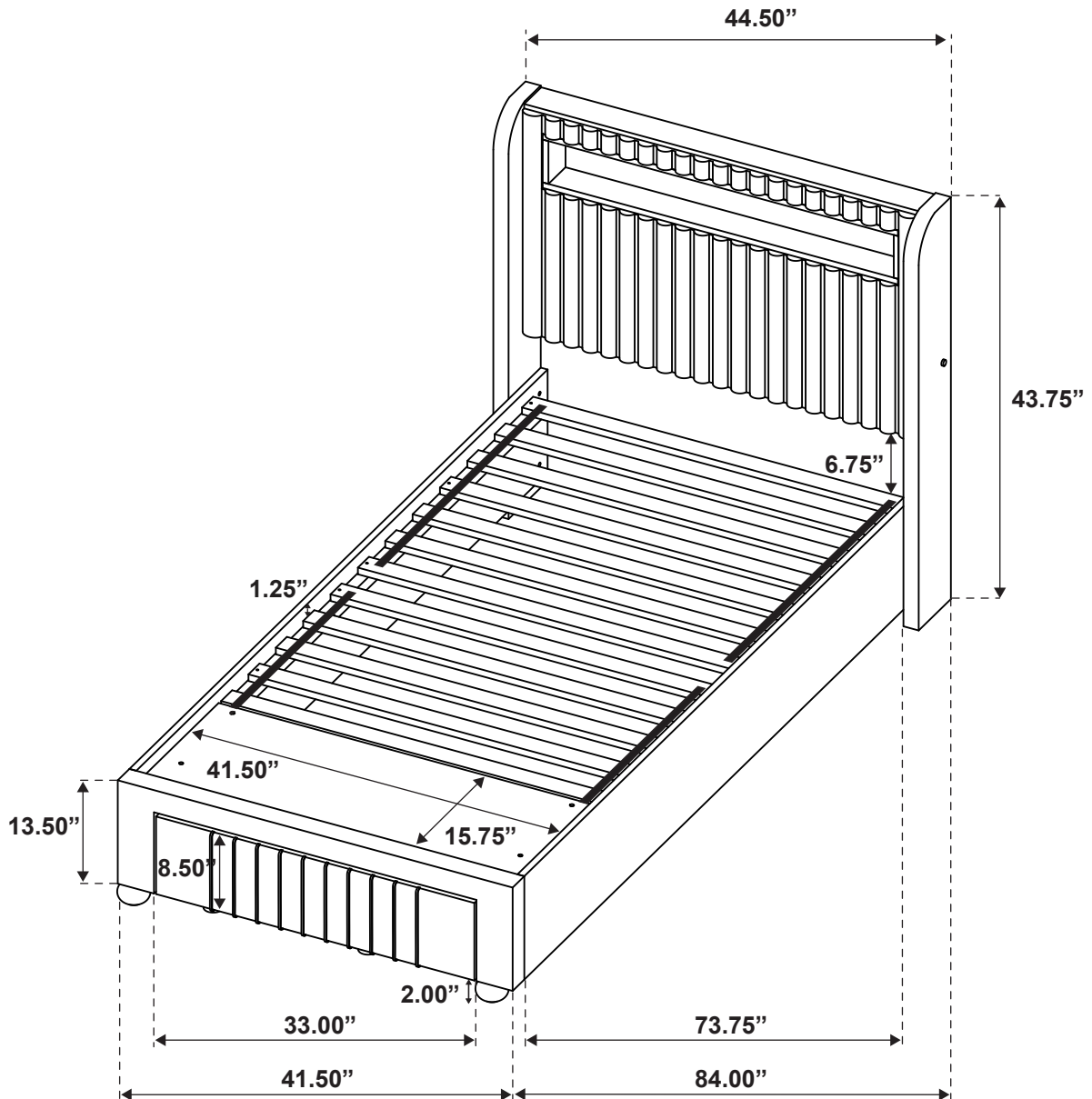

Note: Dimension tolerance $\pm 5\%$