

*ASSEMBLY INSTRUCTIONS*  
*COASTER FINE FURNITURE*



*Fine Furniture for every stage of life*

708158  
**COFFEE TABLE**

ITEM: 708158



# ASSEMBLY INSTRUCTIONS

## ASSEMBLY TIPS:

1. Remove hardware from box and sort by size.
2. Please check to see that all hardware and parts are present prior to start of assembly.
3. Please follow attached instructions in the same sequence as numbered to assure fast & easy assembly.



### WARNING!

1. Don't attempt to repair or modify parts that are broken or defective. Please contact the store immediately.
2. This product is for home use only and not intended for commercial establishments.

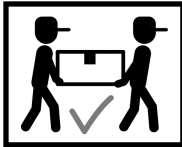

ASSEMBLY TIME 35 MINUTES

## PARTS IDENTIFICATION

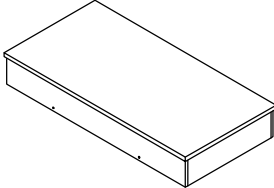
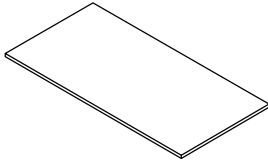
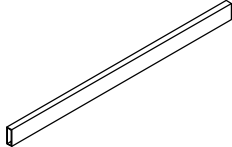
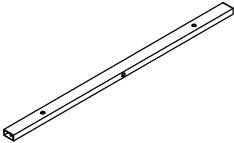
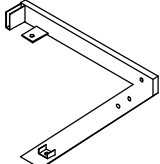
A	TOP		1PC
B	SHELF		1PC
C	TOP CROSSBAR		2PCS
D	BOTTOM CROSSBAR		2PCS
E	LEG 1		2PCS

ITEM:708158

# ASSEMBLY INSTRUCTIONS

## PARTS IDENTIFICATION



F

LEG 2

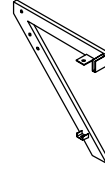

2PCS

G

BOTTOM SUPPORT CROSSBAR

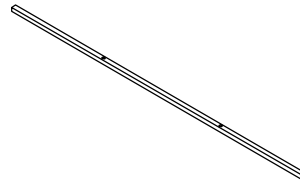

1PC

H

TOP SUPPORT CROSSBAR

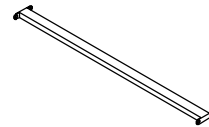

2PCS

ITEM:708158



# ASSEMBLY INSTRUCTIONS

## Z HARDWARE IDENTIFICATION

1 SHORT BOLT  
(1/4" x 12mm SR) 24PCS



2 MEDIUM BOLT  
(1/4" x 22mm SR) 8PCS



3 CAP 4PCS

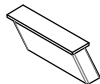

4 LONG BOLT  
(1/4" x 47mm SR) 2PCS



5 SCREW  
(4 x 25mm SR) 2PCS

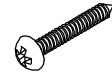

6 WASHER 4PCS



7 ALLEN WRENCH  
(4mm) 1PC

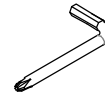

## STEP 1

Do not tighten until each step is completed or instructed.

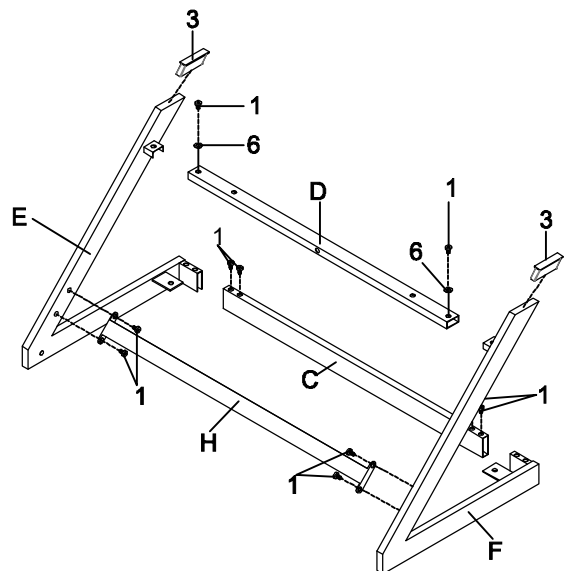
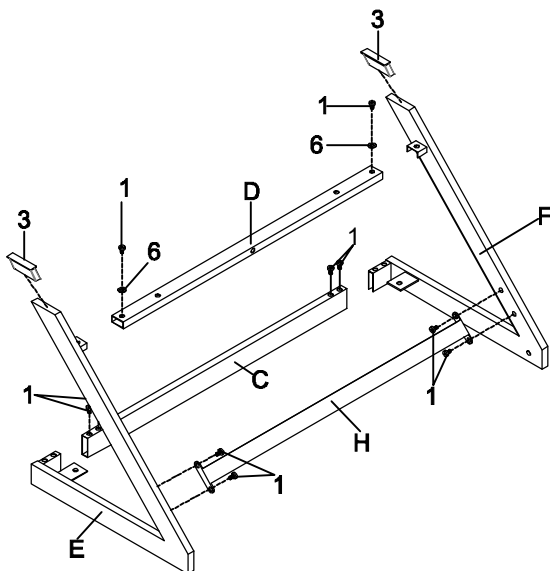

ITEM: 708158

# ASSEMBLY INSTRUCTIONS

## STEP 2

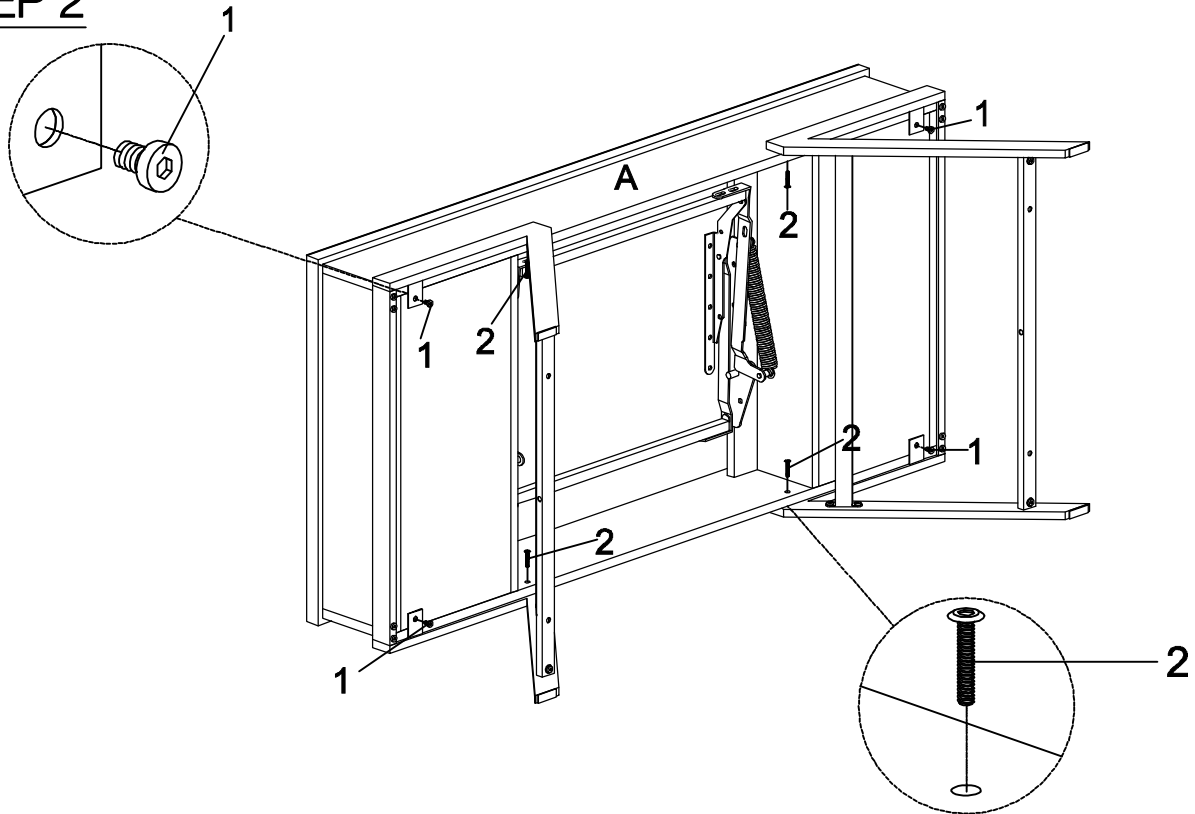

## STEP 3

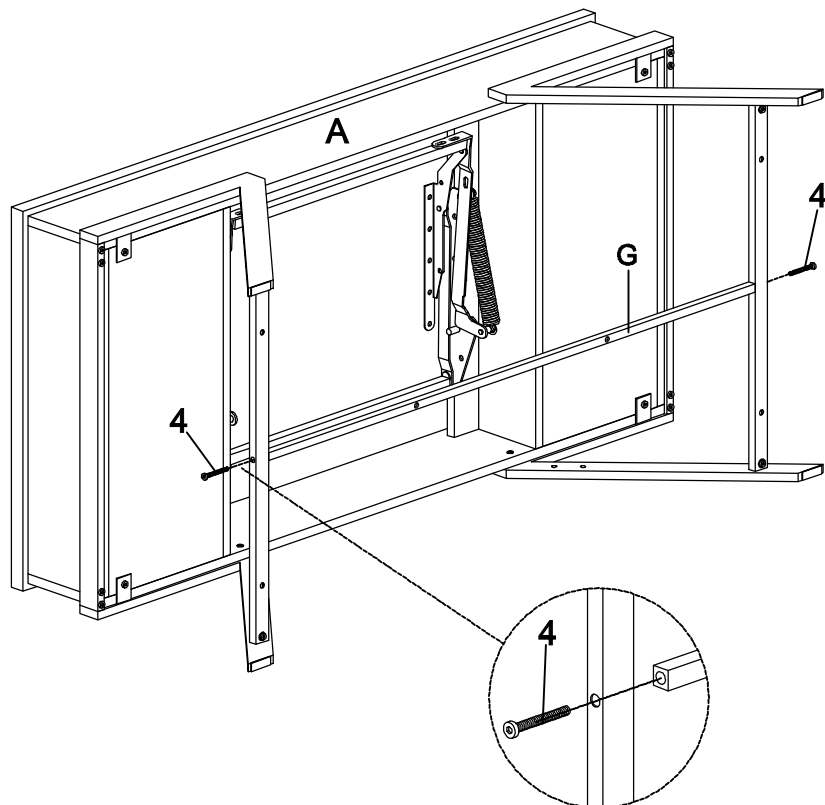

ITEM: 708158

# ASSEMBLY INSTRUCTIONS

## STEP 4

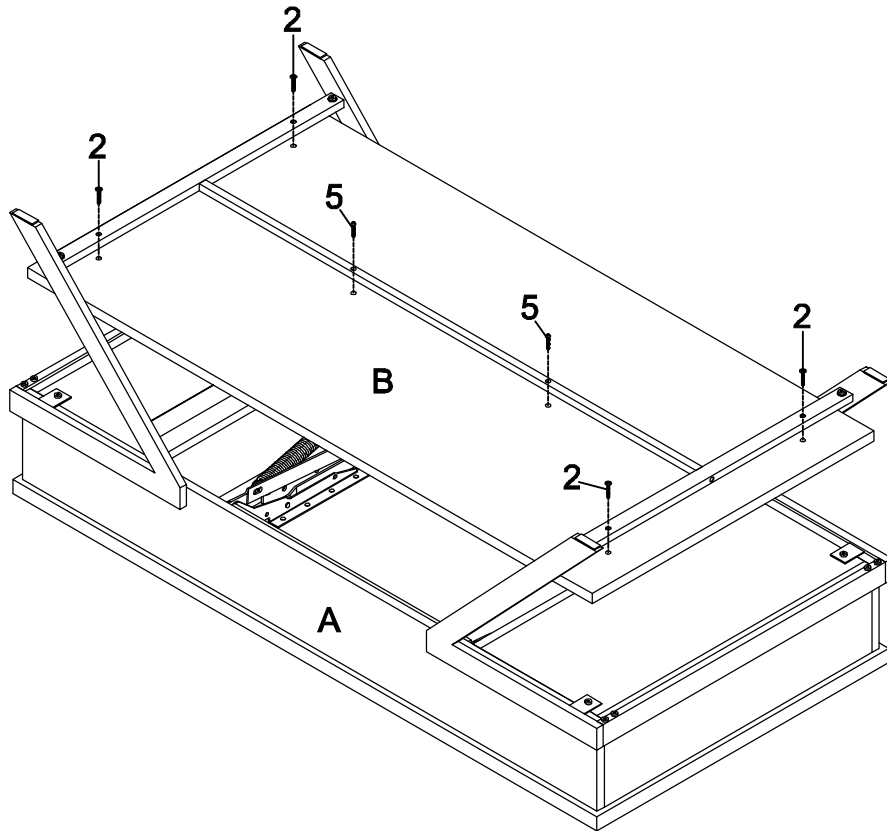

## STEP 5

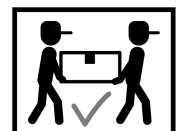
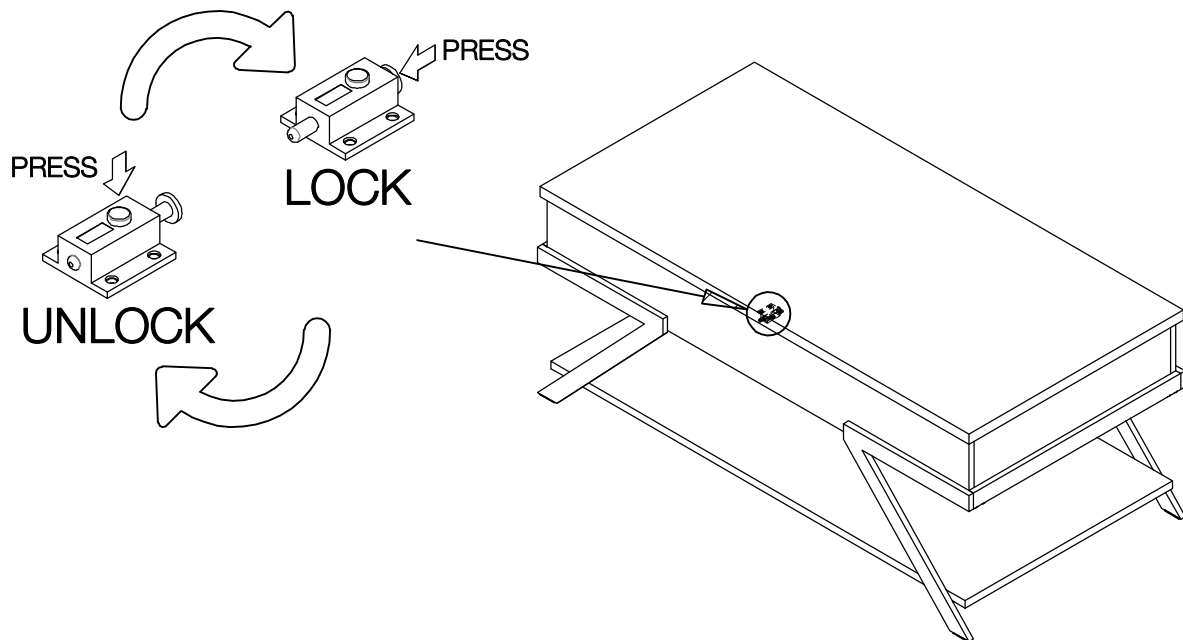

# ITEM: 708158 ASSEMBLY INSTRUCTIONS



**Product Size : 1207 X 597 X 495~737 H (MM)**  
**Product Size : 47.5" X 23.5" X 19.5"~29"**

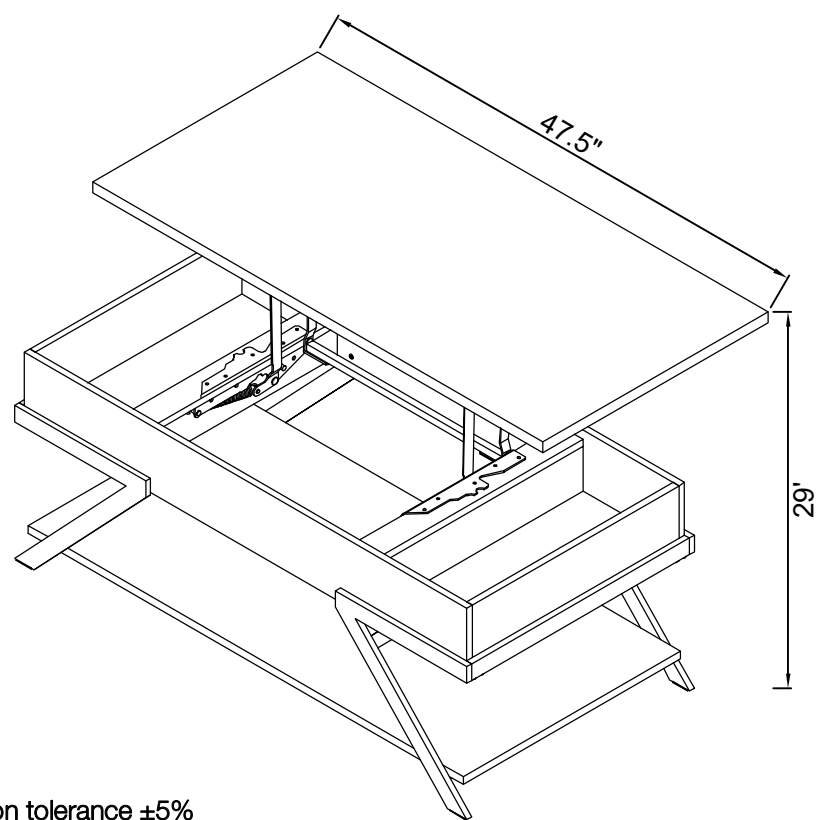
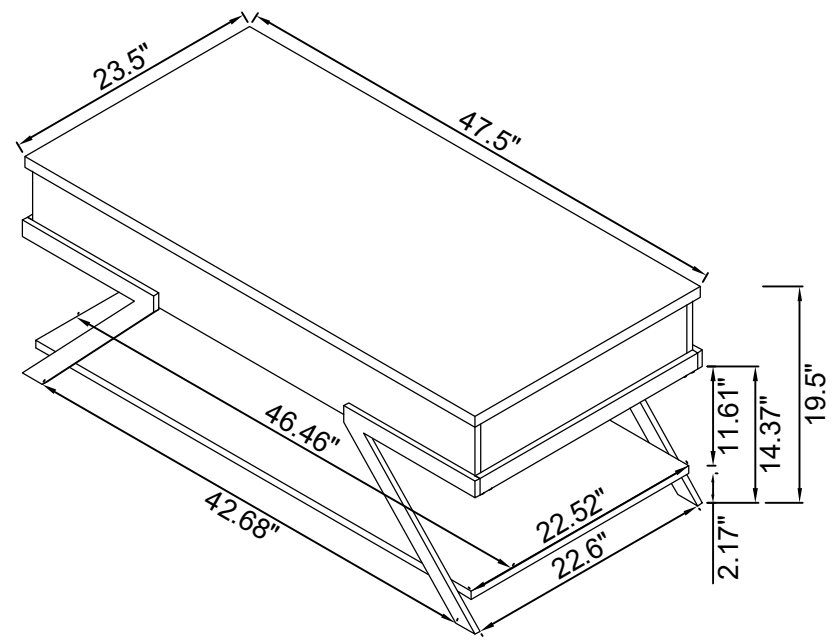

Note : Dimension tolerance  $\pm 5\%$