



ASSEMBLY INSTRUCTIONS COASTER FINE FURNITURE



Fine Furniture for every stage of life

202411F (B1&B2)
Full Bed

REVISION 0 : 04/24/2012
REVISION 1 : 11/29/2017
REVISION 2 : 09/20/2018
REVISION 3 : 11/29/2019
REVISION 4 : 08/01/2024

ITEM: 202411F (B1&B2)



ASSEMBLY INSTRUCTIONS

ASSEMBLY TIPS:

1. Remove hardware from box and sort by size.
2. Please check to see that all hardware and parts are present prior to start of assembly.
3. Please follow attached instructions in the same sequence as numbered to assure fast & easy assembly.



WARNING!

1. Don't attempt to repair or modify parts that are broken or defective. Please contact the store immediately.
2. This product is for home use only and not intended for commercial establishments.









ASSEMBLY TIME

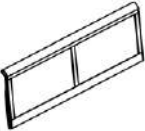

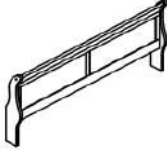
20 MINUTES

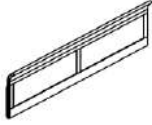
PARTS IDENTIFICATION

B1 (BOX 1)

| | | | | | | | |
|----|---------------------------|---|-----|-----|---|--|-----|
| AN | HEADBOARD PANEL |  | 1PC | HBN | 202411F(B1) *FROM BOX 1 HEADBOARD COMPLETE |  | 1PC |
| BN | LEFT HEADBOARD LEG |  | 1PC | FBN | 202411F(B1) *FROM BOX 1 FOOTBOARD |  | 1PC |
| CN | RIGHT HEADBOARD LEG |  | 1PC | | | | |
| DN | FOOTBOARD PANEL |  | 1PC | | | | |
| EN | LEFT FOOTBOARD LEG |  | 1PC | | | | |
| FN | RIGHT FOOTBOARD LEG |  | 1PC | | | | |

B2 (BOX 2)

| | | | |
|----|--|---|------|
| GN | BED RAIL |  | 2PCS |
| HN | BED SLAT |  | 4PCS |
| | BED SLAT IN SUPPORT WITH LEVELER |  | 4PCS |

NOTE:

Phillips head screw driver is required in the assembly process; however, manufacturer does not provide this item.

ITEM: 202411F (B1&B2)



ASSEMBLY INSTRUCTIONS

ASSEMBLY TIPS:

1. Remove hardware from box and sort by size.
2. Please check to see that all hardware and parts are present prior to start of assembly.
3. Please follow attached instructions in the same sequence as numbered to assure fast & easy assembly.









WARNING!

1. Don't attempt to repair or modify parts that are broken or defective. Please contact the store immediately.
2. This product is for home use only and not intended for commercial establishments.

HARDWARE IDENTIFICATION

Z-B1 (BOX 1) - HARDWARE PACK IS LOCATED IN 202411F(B1)

| | | | |
|---|---|---|-------|
| 1 | BOLT (M6 x 35mm - BLK) |  | 12PCS |
| 2 | LOCK WASHER (M6 - BLK) |  | 12PCS |
| 3 | SMALL FLAT WASHER (M6 x 13mm - BLK) |  | 4PCS |
| 4 | BIG FLAT WASHER (M6 x 19mm - BLK) |  | 8PCS |
| 5 | ALLEN WRENCH (M4 x 65mm - BLK) |  | 1PC |
| 6 | WOOD PLUG (14.50mm - CHY) |  | 4PCS |
| 7 | PAN HEAD SCREW (M4 x 30mm - BLK) |  | 8PCS |

NOTE:

Phillips head screw driver is required in the assembly process; however, manufacturer does not provide this item.

ITEM: 202411F (B1&B2)

ASSEMBLY INSTRUCTIONS

202411F (B1) - BOX 1

STEP 1

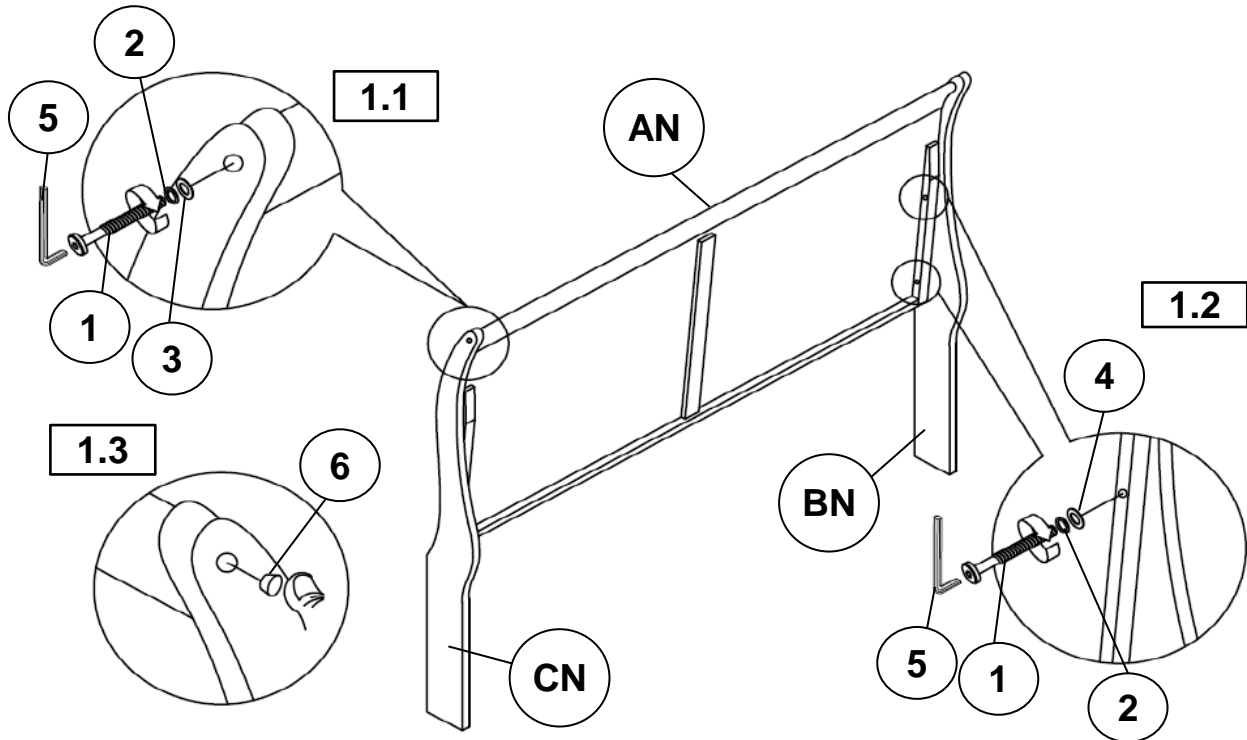

STEP 2

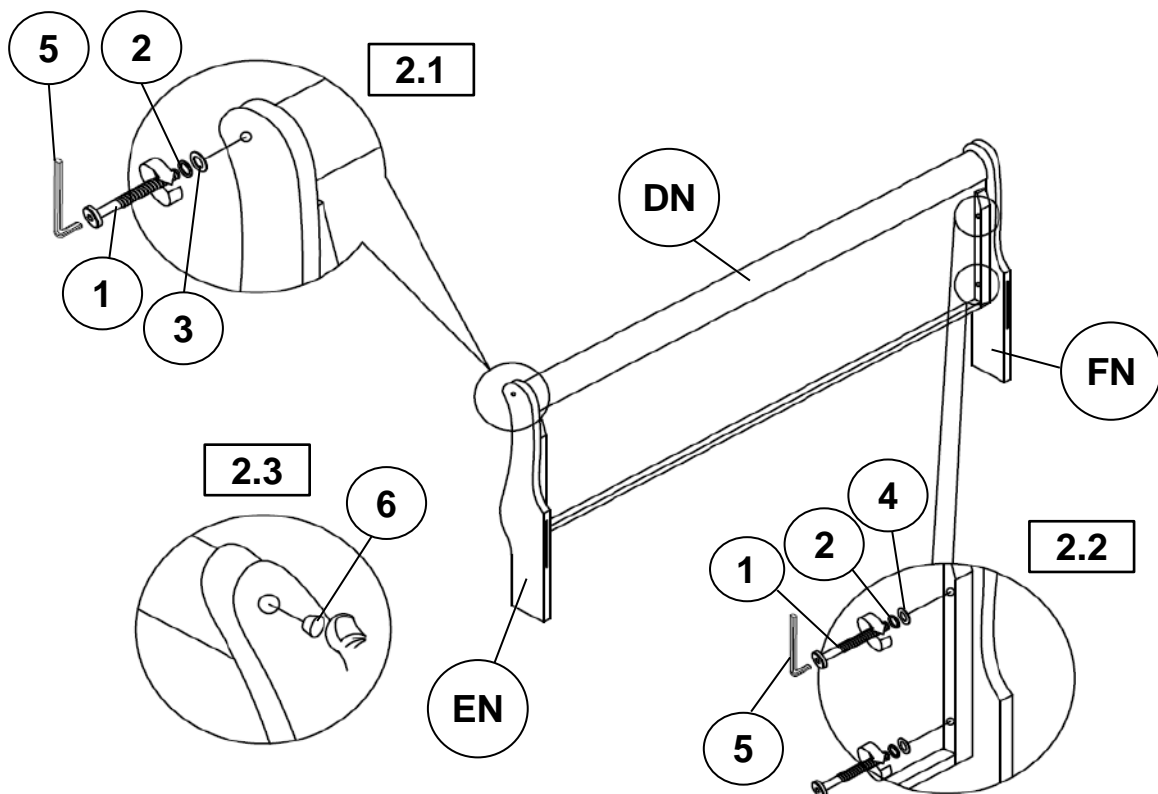

ITEM: 202411F (B1&B2)



ASSEMBLY INSTRUCTIONS

202411F (B1&B2) - BOX 1 & BOX 2

STEP 3

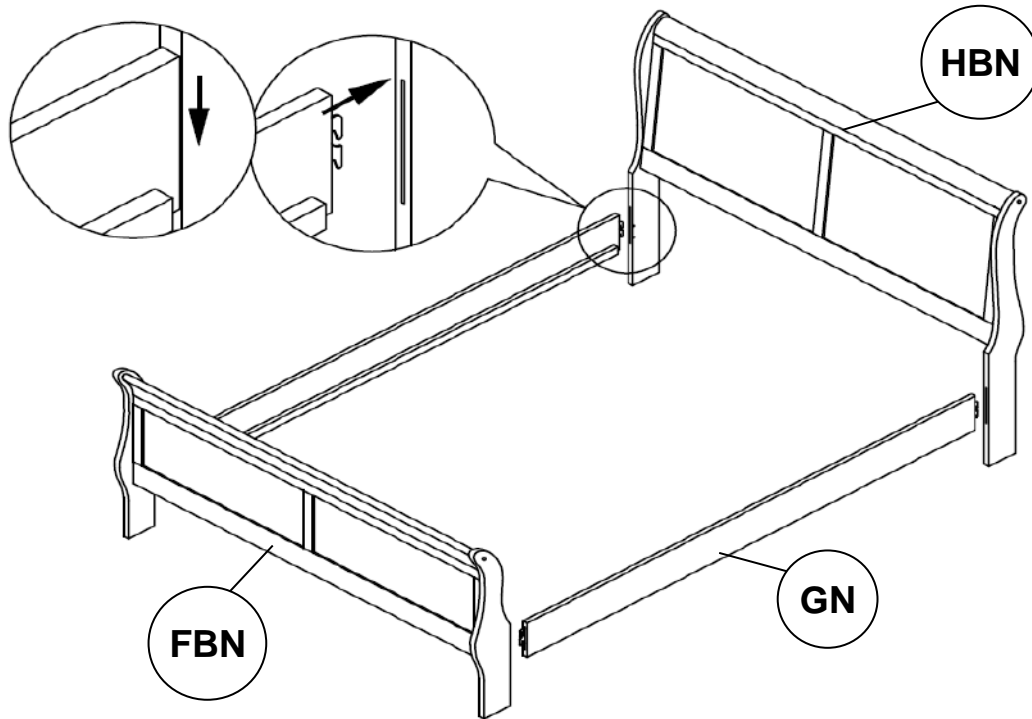

STEP 4

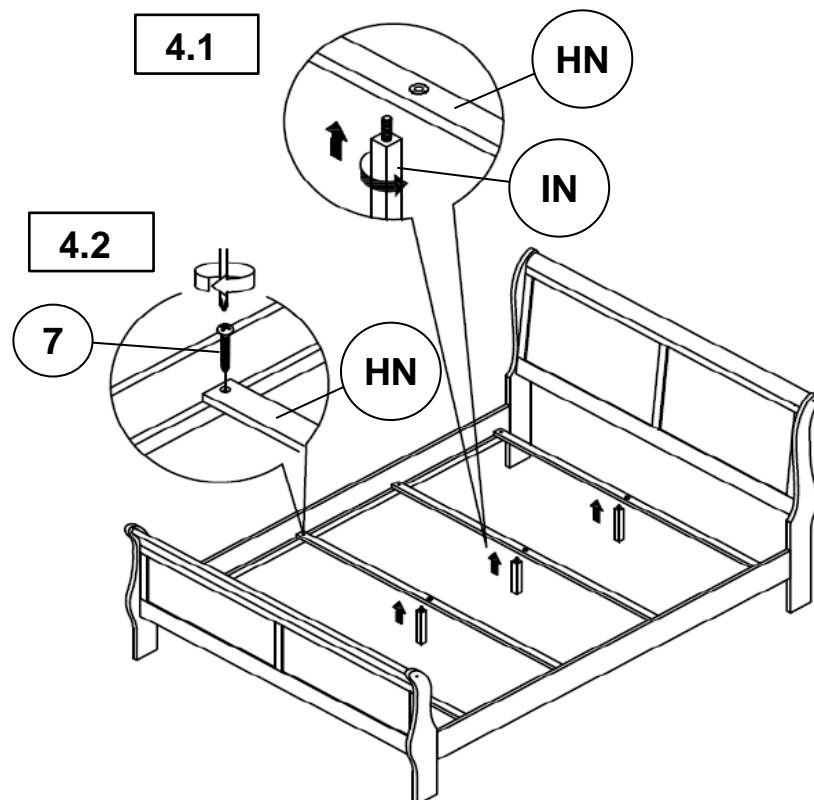

ITEM: **202411F (B1&B2)**



ASSEMBLY INSTRUCTIONS

STEP 5
COMPLETE

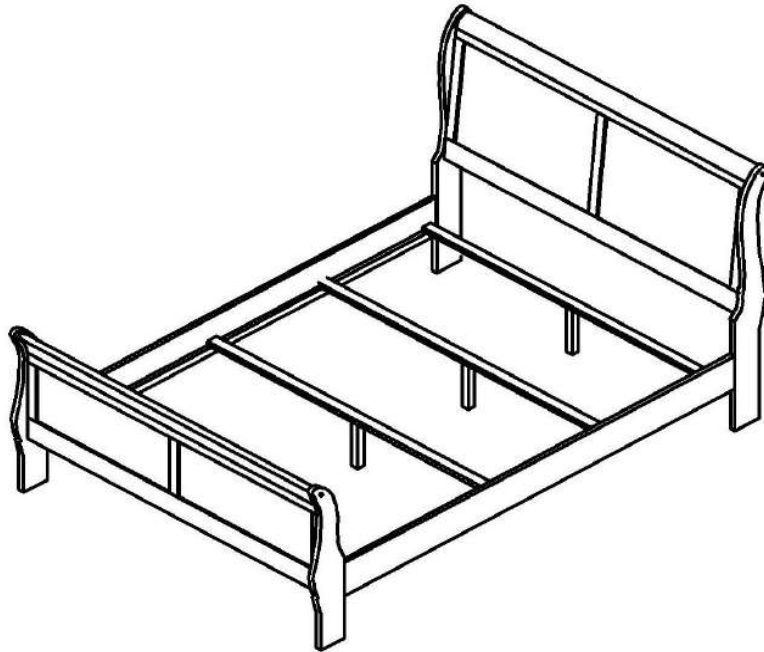

ITEM:202411F (B1&B2)



Inner Size : 54.75"W x 75.50"D

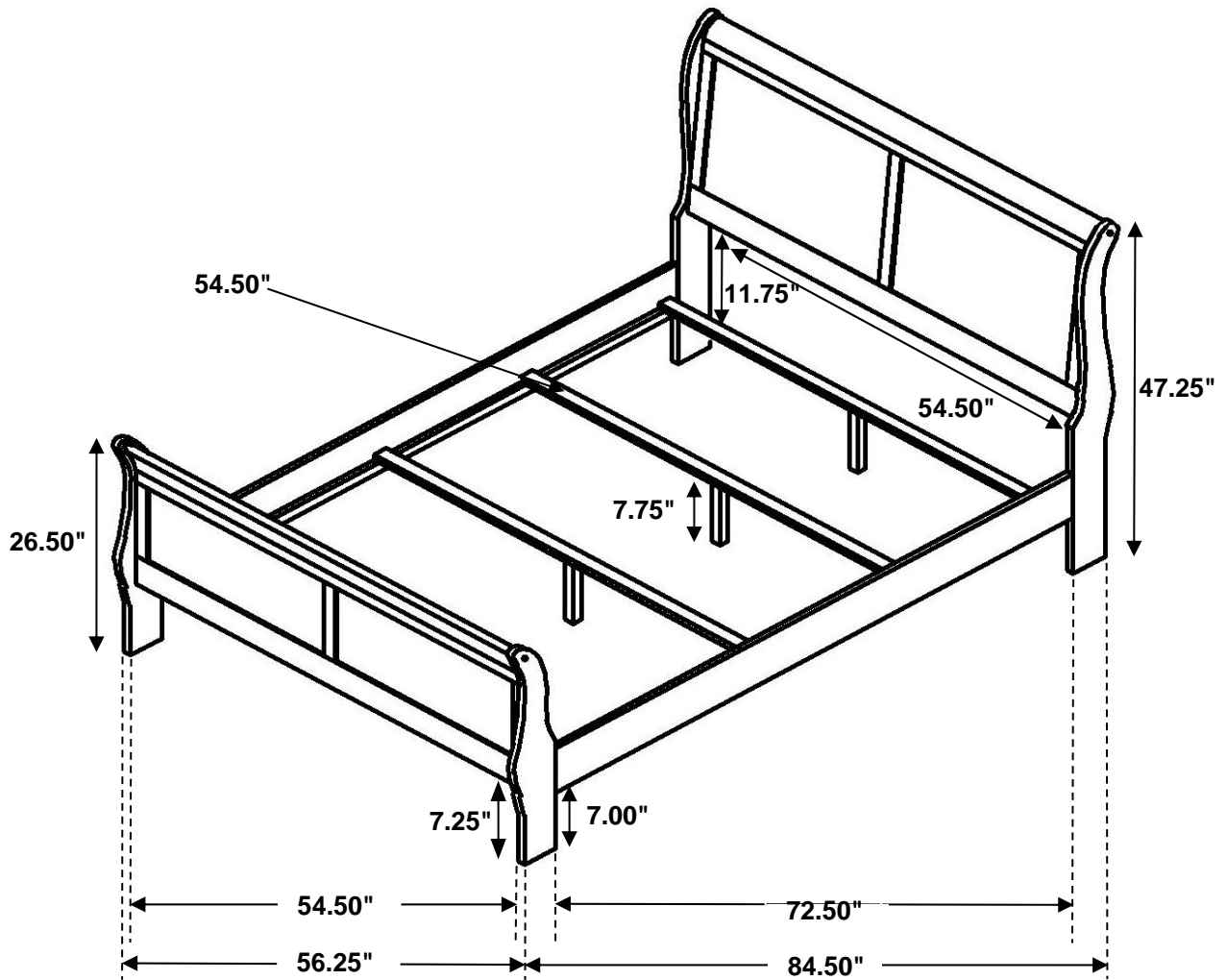

Note : Dimension tolerance $\pm 5\%$