

ASSEMBLY INSTRUCTIONS
COASTER FINE FURNITURE

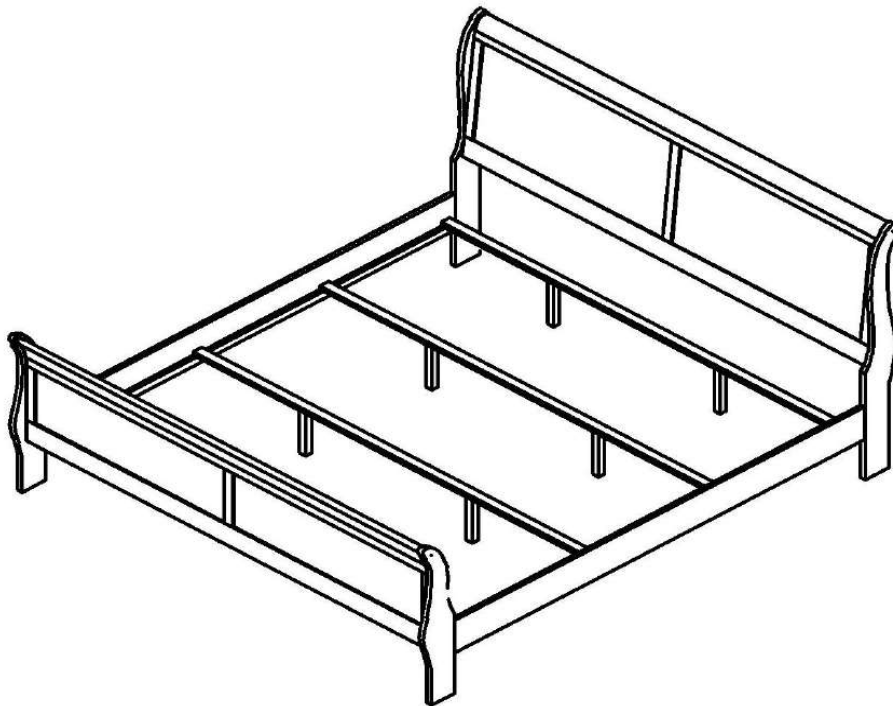

Fine Furniture for every stage of life

202411KE(B1&B2)
Eastern King Bed

REVISION 0 : 04/24/2012
REVISION 1 : 11/29/2017
REVISION 2 : 09/20/2018
REVISION 3 : 11/29/2019
REVISION 4 : 08/01/2024

ITEM: 202411KE (B1&B2)



ASSEMBLY INSTRUCTIONS

ASSEMBLY TIPS:

1. Remove hardware from box and sort by size.
2. Please check to see that all hardware and parts are present prior to start of assembly.
3. Please follow attached instructions in the same sequence as numbered to assure fast & easy assembly.



WARNING!

1. Don't attempt to repair or modify parts that are broken or defective. Please contact the store immediately.
2. This product is for home use only and not intended for commercial establishments.









ASSEMBLY TIME

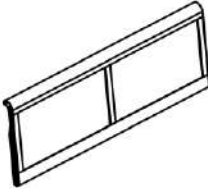
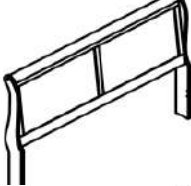

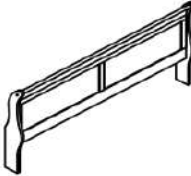
20 MINUTES

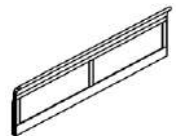
PARTS IDENTIFICATION

B1 (BOX 1)

AN	HEADBOARD PANEL		1PC	HBN	202411KE(B1) *FROM BOX 1 HEADBOARD COMPLETE		1PC
BN	LEFT HEADBOARD LEG		1PC	FBN	202411KE(B1) *FROM BOX 1 FOOTBOARD		1PC
CN	RIGHT HEADBOARD LEG		1PC				
DN	FOOTBOARD PANEL		1PC				
EN	LEFT FOOTBOARD LEG		1PC				
FN	RIGHT FOOTBOARD LEG		1PC				

B2 (BOX 2)

GN	BED RAIL		2PCS
HN	BED SLAT		4PCS
IN	BED SLAT IN SUPPORT WITH LEVELER		8PCS

NOTE:

Phillips head screw driver is required in the assembly process; however, manufacturer does not provide this item.

ITEM: 202411KE (B1&B2)



ASSEMBLY INSTRUCTIONS

ASSEMBLY TIPS:

1. Remove hardware from box and sort by size.
2. Please check to see that all hardware and parts are present prior to start of assembly.
3. Please follow attached instructions in the same sequence as numbered to assure fast & easy assembly.









WARNING!

1. Don't attempt to repair or modify parts that are broken or defective. Please contact the store immediately.
2. This product is for home use only and not intended for commercial establishments.

HARDWARE IDENTIFICATION

Z-B1 (BOX 1) - HARDWARE PACK IS LOCATED IN 202411KE(B1)

1	BOLT (M6 x 35mm - BLK)		12PCS
2	LOCK WASHER (M6 - BLK)		12PCS
3	SMALL FLAT WASHER (M6 x 13mm - BLK)		4PCS
4	BIG FLAT WASHER (M6 x 19mm - BLK)		8PCS
5	ALLEN WRENCH (M4 x 65mm - BLK)		1PC
6	WOOD PLUG (14.50mm - CHY)		4PCS
7	PAN HEAD SCREW (M4 x 30mm - BLK)		8PCS

NOTE:

Phillips head screw driver is required in the assembly process; however, manufacturer does not provide this item.

ITEM: 202411KE (B1&B2)

ASSEMBLY INSTRUCTIONS

202411KE(B1) - BOX 1

STEP 1

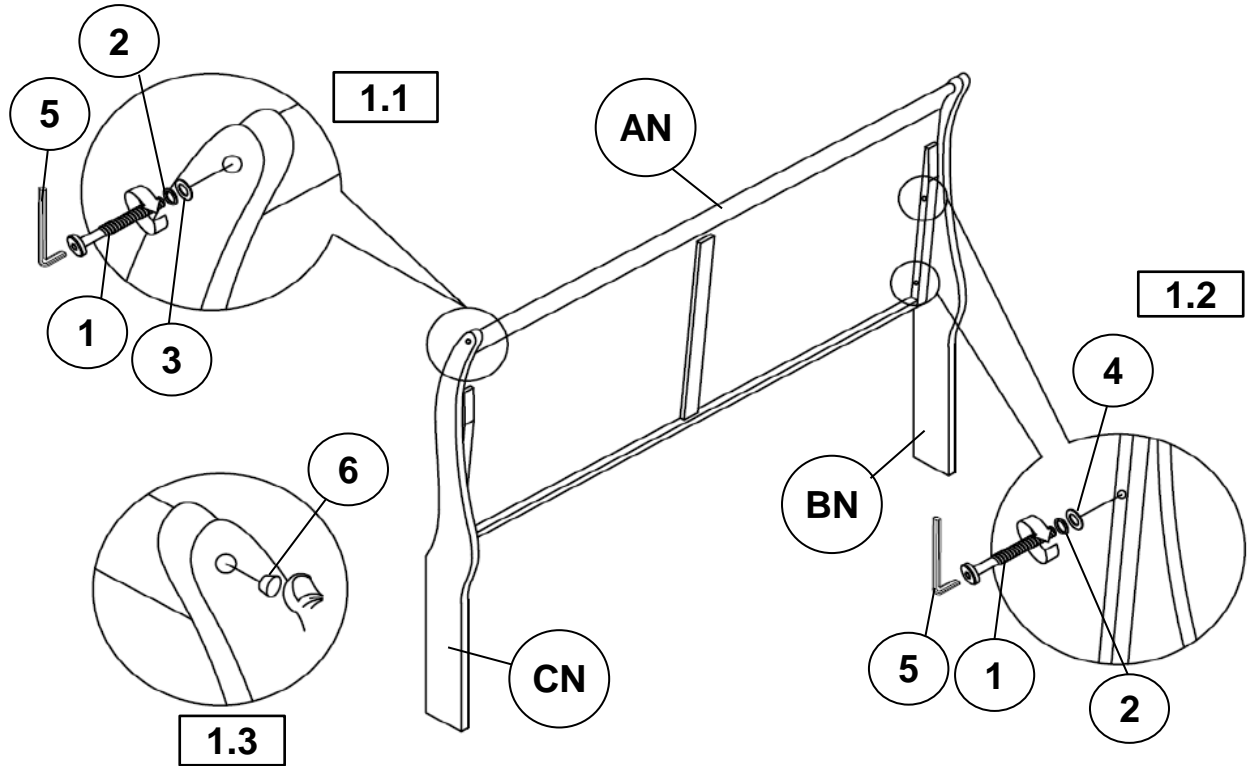

STEP 2

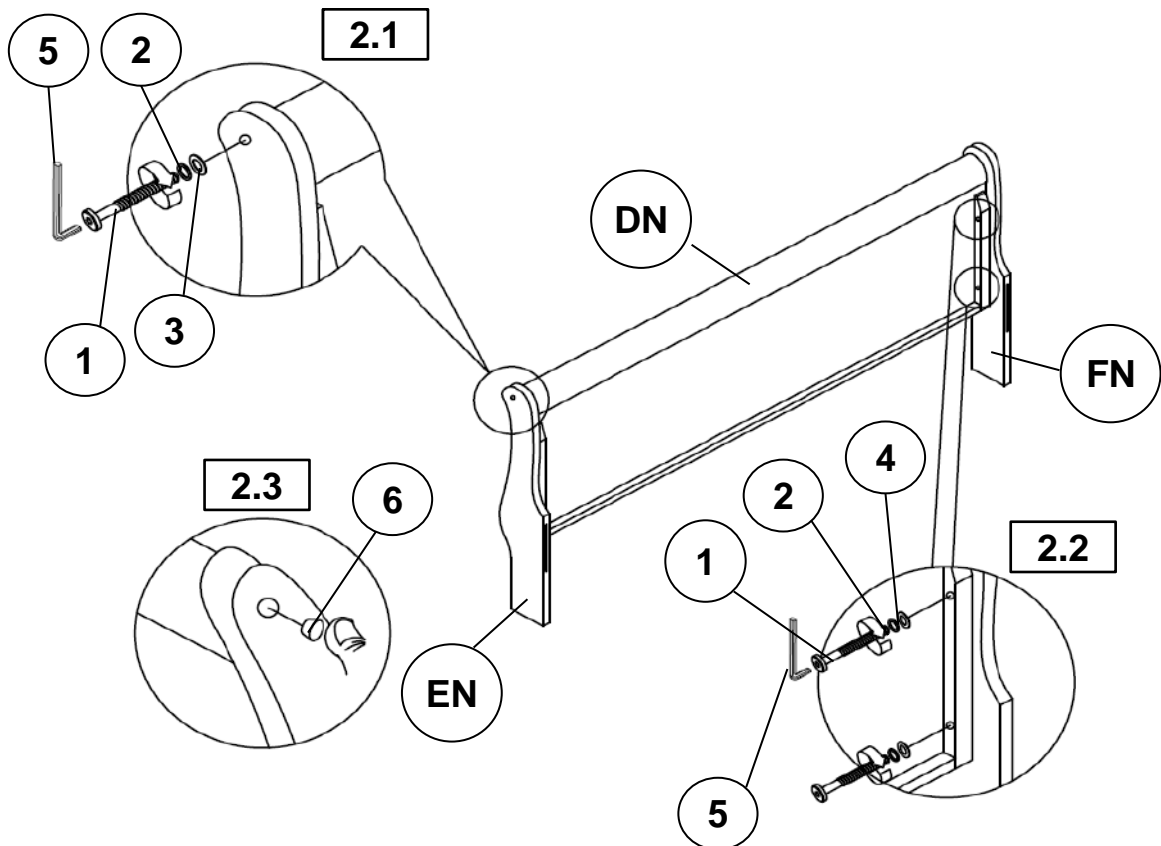

ITEM: 202411KE (B1&B2)



ASSEMBLY INSTRUCTIONS

202411KE(B1&B2) - BOX 1 & BOX 2

STEP 3

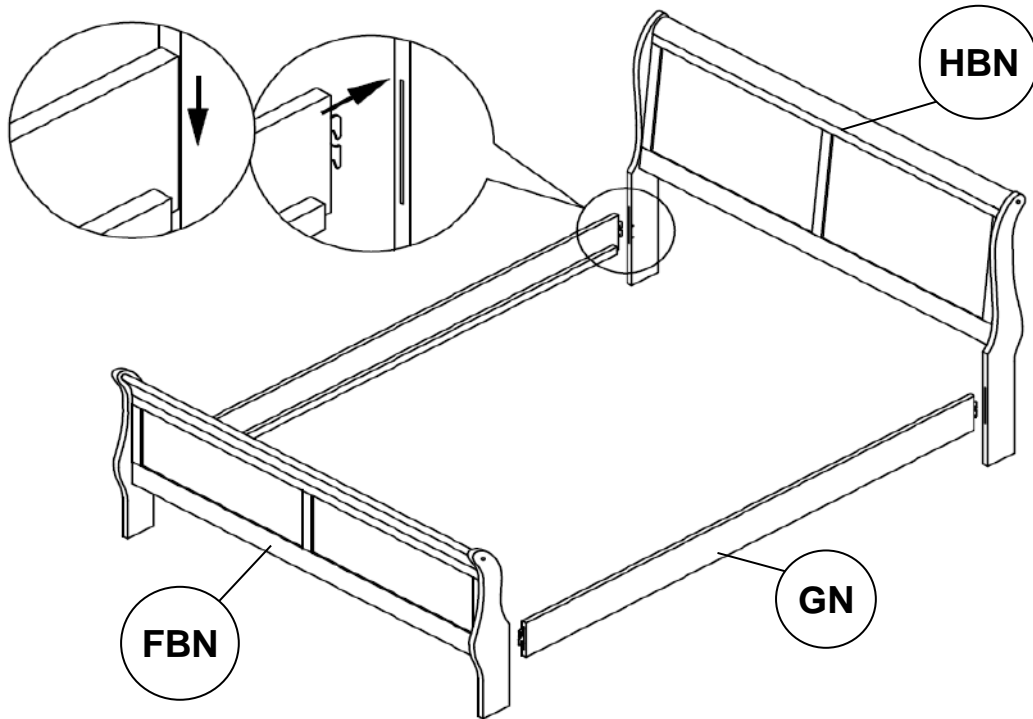

STEP 4

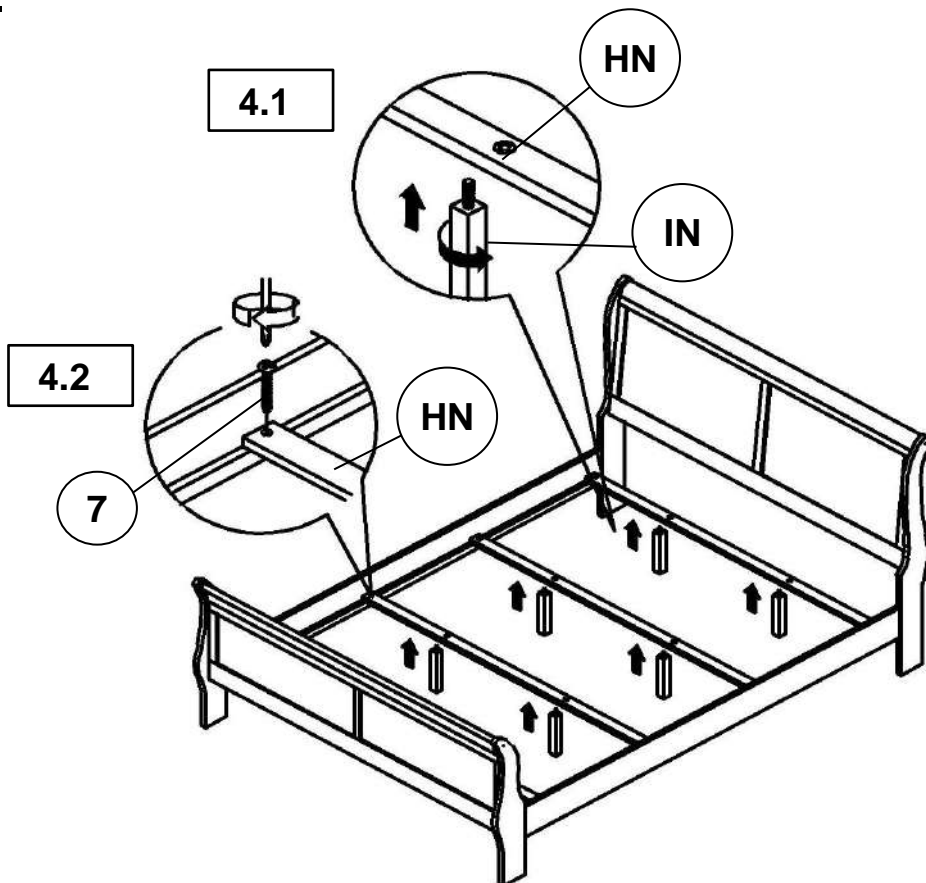

ITEM: **202411KE (B1&B2)**



ASSEMBLY INSTRUCTIONS

STEP 5
COMPLETE

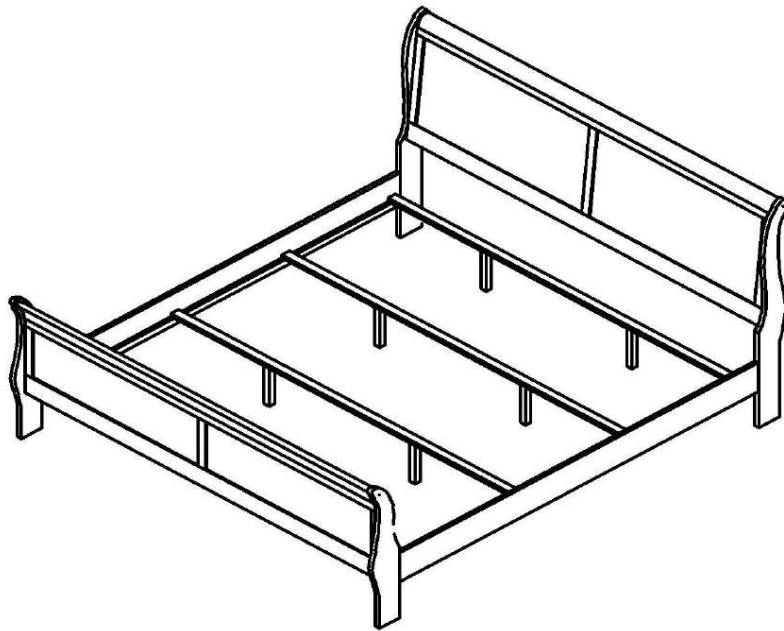

ITEM: 202411KE (B1&B2)



Inner Size : 76.25"W x 80.50"D

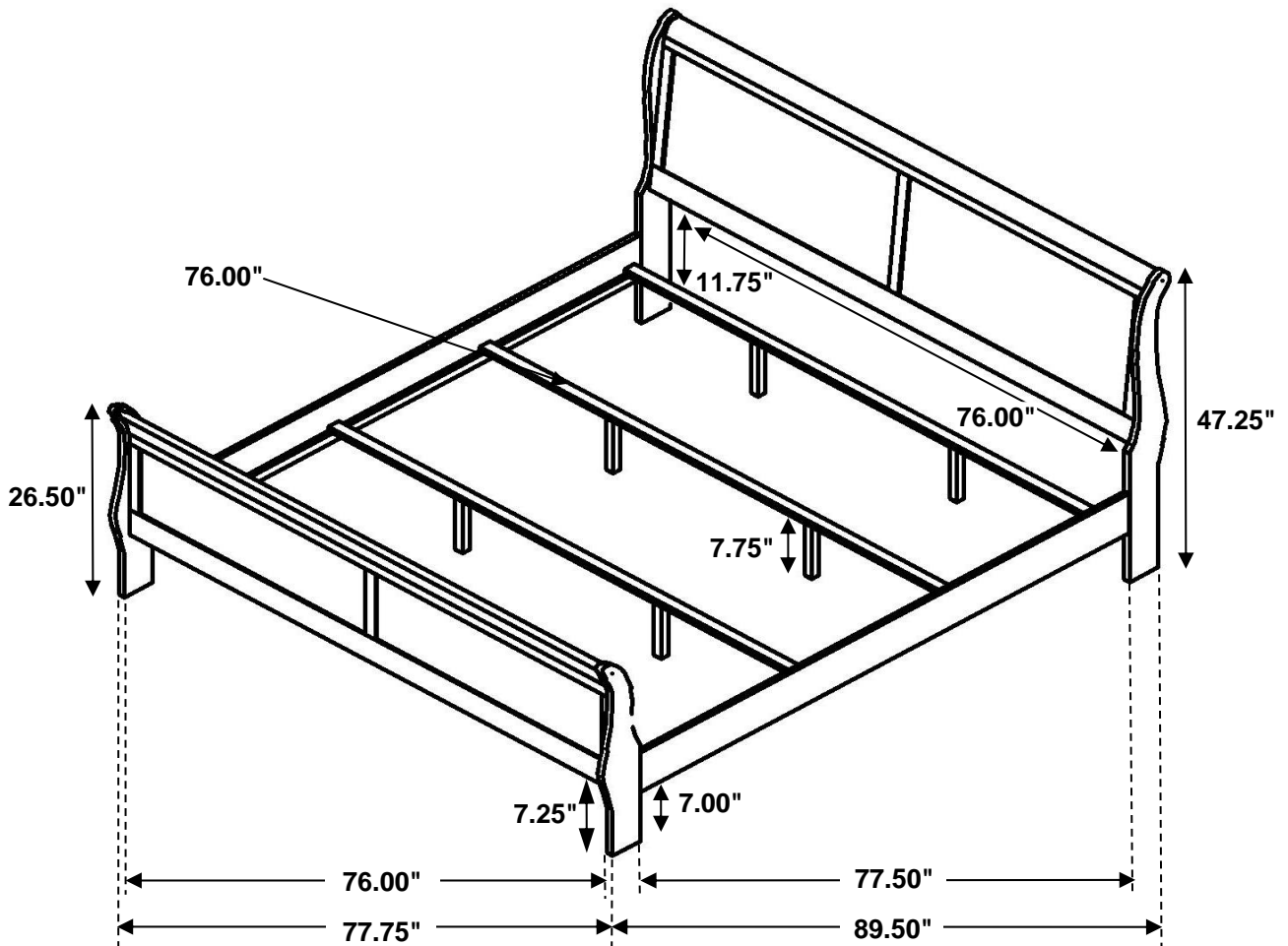

Note : Dimension tolerance $\pm 5\%$