

**ASSEMBLY INSTRUCTIONS**  
**COASTER FINE FURNITURE**



*Fine Furniture for every stage of life*

**202411T (B1&B2)**  
**Twin Bed**

REVISION 0 : 04/24/2012  
REVISION 1 : 11/29/2017  
REVISION 2 : 09/20/2018  
REVISION 3 : 11/29/2019  
REVISION 4 : 08/01/2024

# ITEM: 202411T (B1&B2)



## ASSEMBLY INSTRUCTIONS

### ASSEMBLY TIPS:

1. Remove hardware from box and sort by size.
2. Please check to see that all hardware and parts are present prior to start of assembly.
3. Please follow attached instructions in the same sequence as numbered to assure fast & easy assembly.



### WARNING!

1. Don't attempt to repair or modify parts that are broken or defective. Please contact the store immediately.
2. This product is for home use only and not intended for commercial establishments.









ASSEMBLY TIME

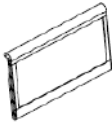

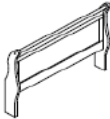
20 MINUTES

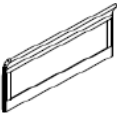
## PARTS IDENTIFICATION

### B1 ( BOX 1 )

AN	HEADBOARD PANEL		1PC	HBN	202411T(B1) *FROM BOX 1 HEADBOARD COMPLETE		1PC
BN	LEFT HEADBOARD LEG		1PC	FBN	202411T(B1) *FROM BOX 1 FOOTBOARD		1PC
CN	RIGHT HEADBOARD LEG		1PC				
DN	FOOTBOARD PANEL		1PC				
EN	LEFT FOOTBOARD LEG		1PC				
FN	RIGHT FOOTBOARD LEG		1PC				

### B2 ( BOX 2 )

GN	BED RAIL		2PCS
HN	BED SLAT		4PCS
	BED SLAT IN SUPPORT WITH LEVELER		4PCS

### NOTE:

Phillips head screw driver is required in the assembly process; however, manufacturer does not provide this item.

# ITEM: 202411T (B1&B2)



## ASSEMBLY INSTRUCTIONS

### ASSEMBLY TIPS:

1. Remove hardware from box and sort by size.
2. Please check to see that all hardware and parts are present prior to start of assembly.
3. Please follow attached instructions in the same sequence as numbered to assure fast & easy assembly.









### WARNING!

1. Don't attempt to repair or modify parts that are broken or defective. Please contact the store immediately.
2. This product is for home use only and not intended for commercial establishments.

## HARDWARE IDENTIFICATION

### Z-B1 (BOX 1) - HARDWARE PACK IS LOCATED IN 202411T(B1)

1	<b>BOLT</b> (M6 x 35mm - BLK)		12PCS
2	<b>LOCK WASHER</b> (M6 - BLK)		12PCS
3	<b>SMALL FLAT WASHER</b> (M6 x 13mm - BLK)		4PCS
4	<b>BIG FLAT WASHER</b> (M6 x 19mm - BLK)		8PCS
5	<b>ALLEN WRENCH</b> (M4 x 65mm - BLK)		1PC
6	<b>WOOD PLUG</b> (14.50mm - CHY)		4PCS
7	<b>PAN HEAD SCREW</b> (M4 x 30mm - BLK)		8PCS

### NOTE:

Phillips head screw driver is required in the assembly process; however, manufacturer does not provide this item.

# ITEM: 202411T (B1&B2)

## ASSEMBLY INSTRUCTIONS

### 202411T (B1) - BOX 1

#### STEP 1

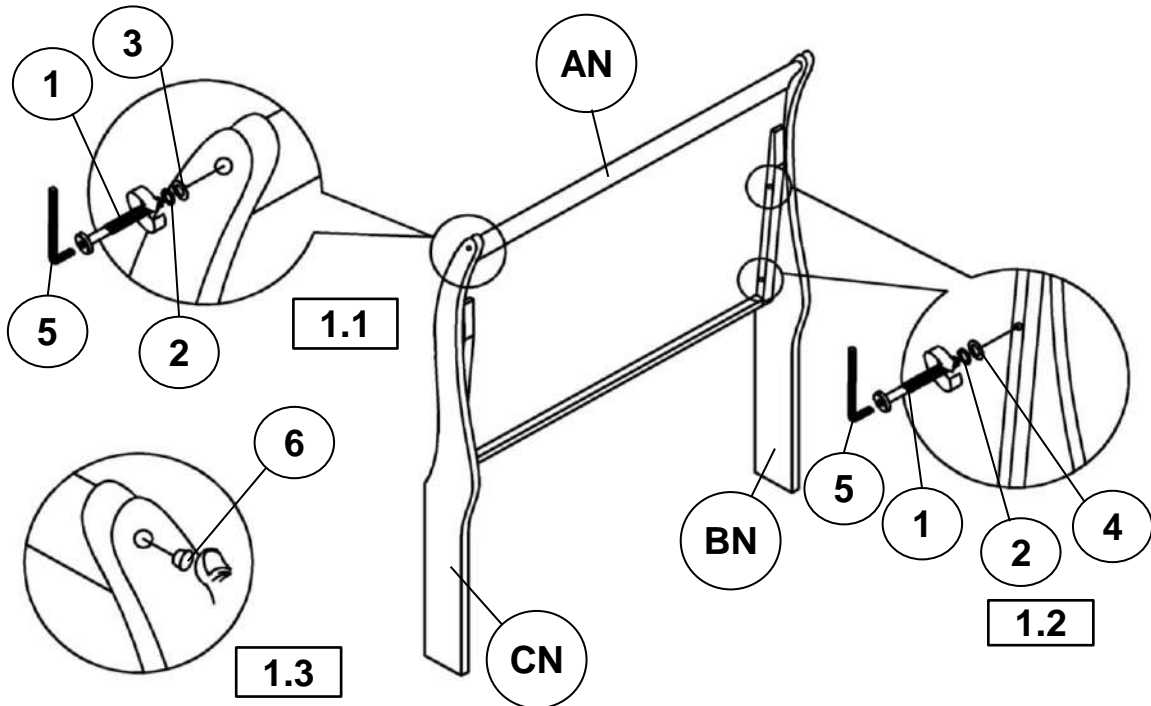

#### STEP 2

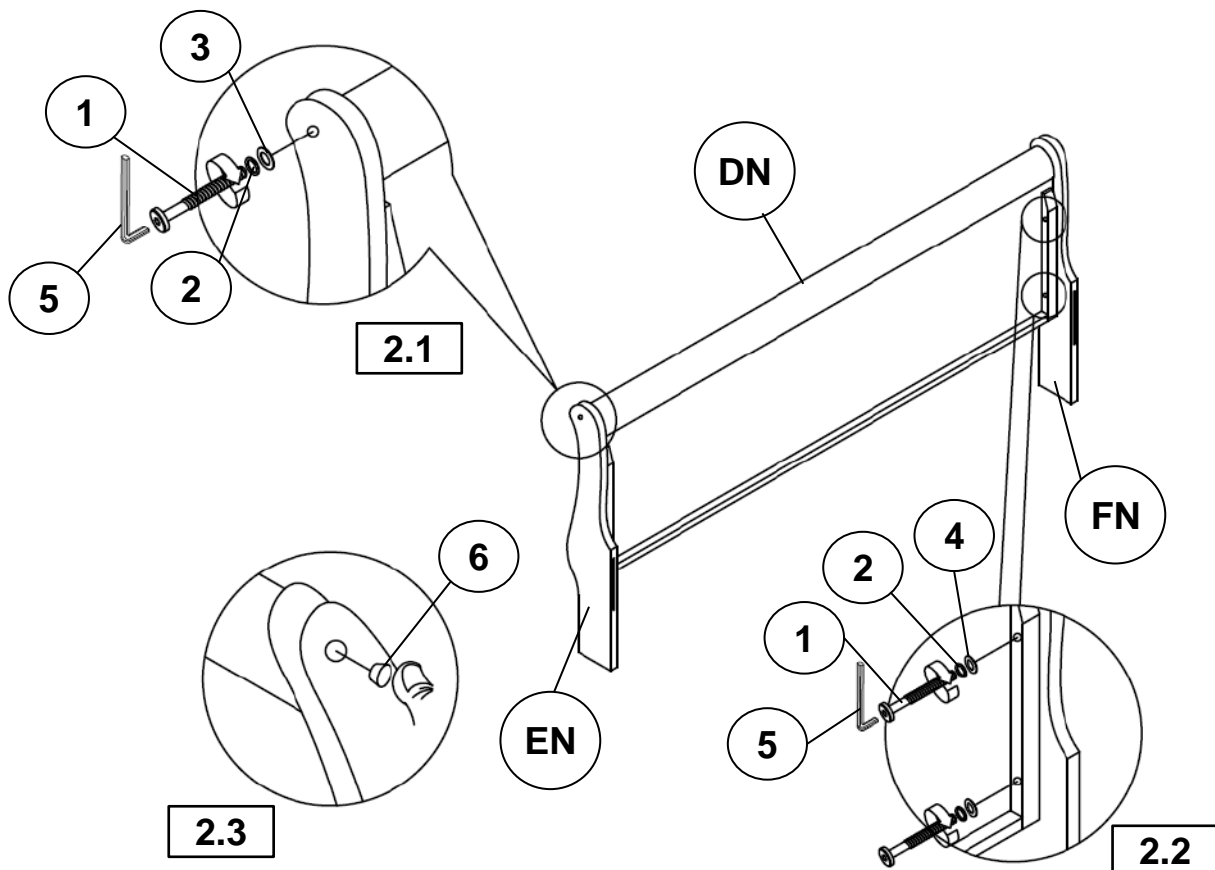

# ITEM: 202411T (B1&B2)



## ASSEMBLY INSTRUCTIONS

### 202411T (B1&B2) - BOX 1 & BOX 2

#### STEP 3

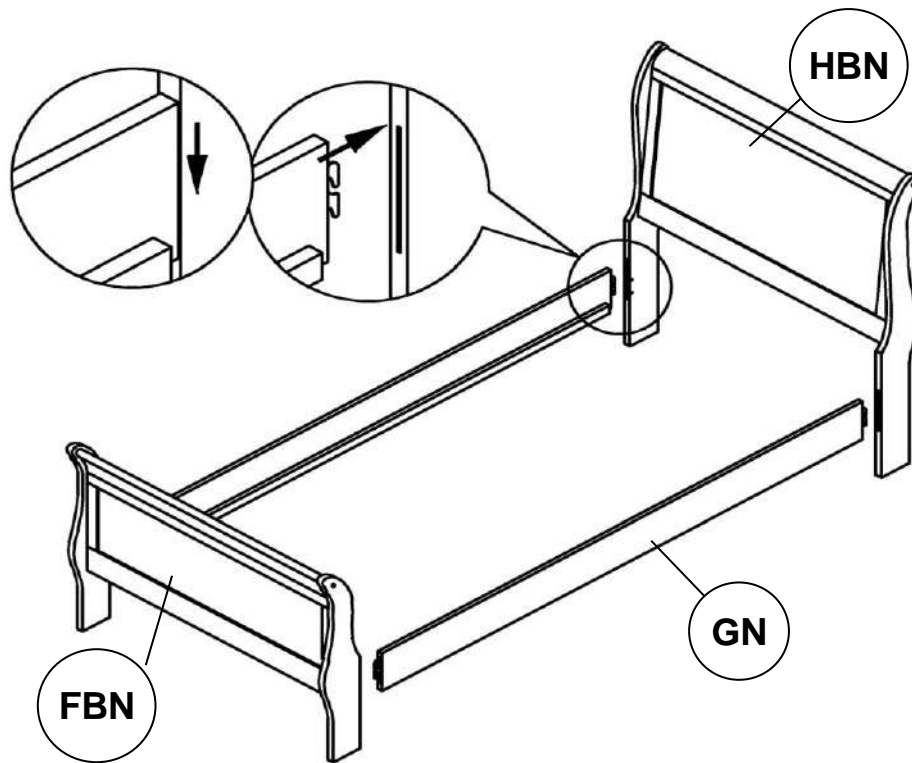

#### STEP 4

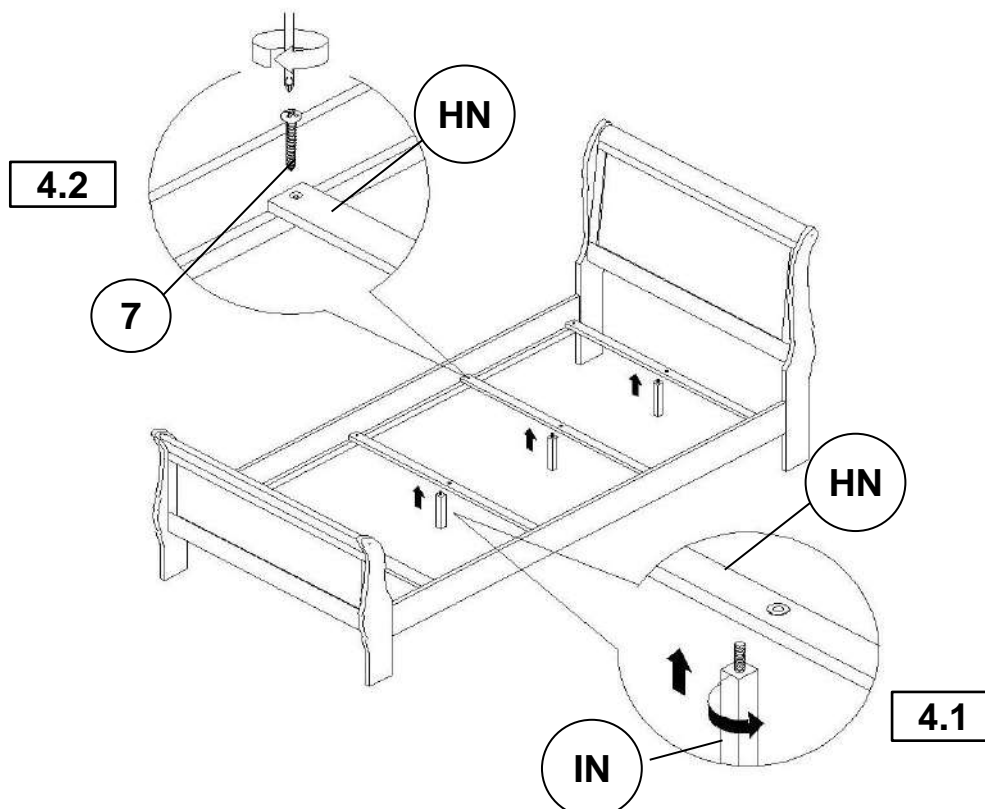

ITEM: **202411T (B1&B2)**



**ASSEMBLY INSTRUCTIONS**

**STEP 5**  
**COMPLETE**

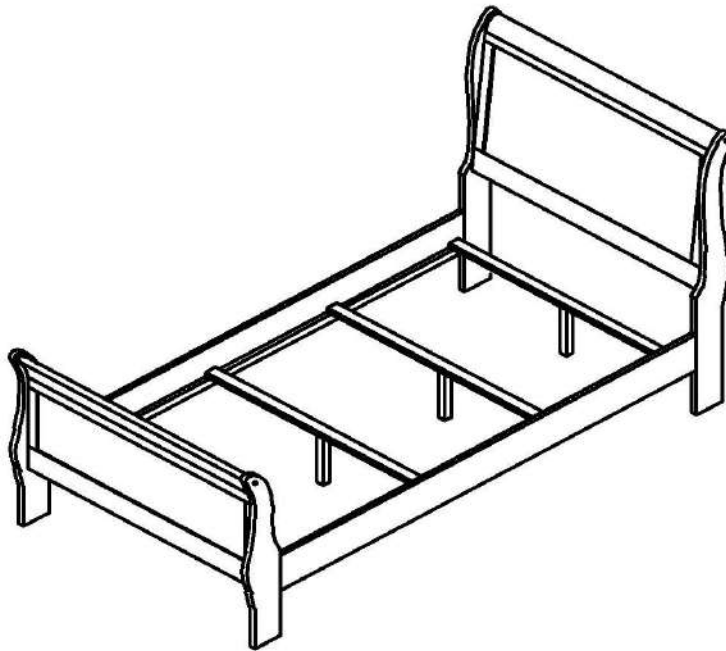

# ITEM: 202411T (B1&B2)



Inner Size : 39.75"W x 75.50"D

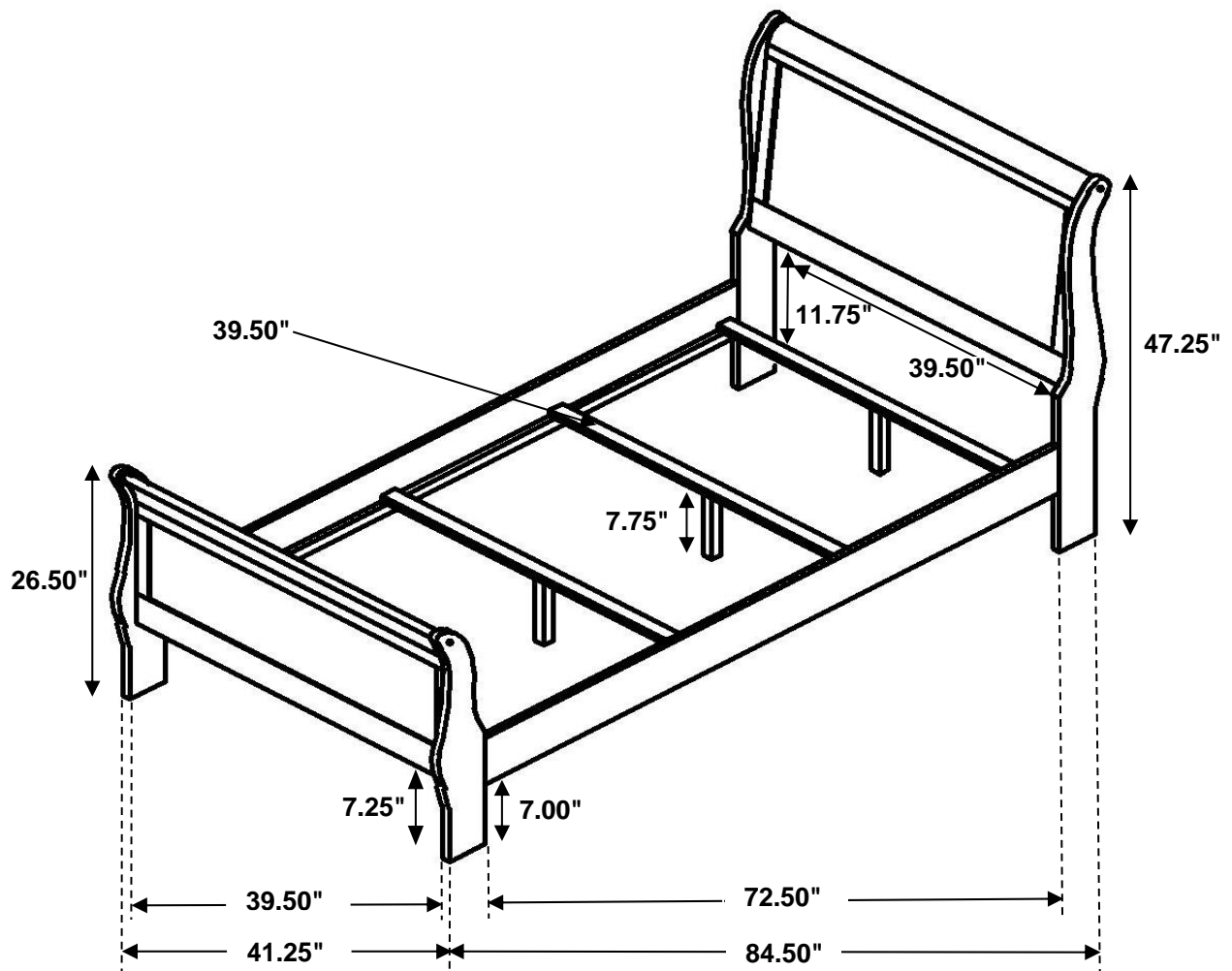

Note : Dimension tolerance  $\pm 5\%$