



ASSEMBLY INSTRUCTIONS
COASTER FINE FURNITURE



Fine Furniture for every stage of life

108091
DINING TABLE

REVISION 0 : 08/16/2024

PAGE 1 OF 7

COASTERFURNITURE.COM

ITEM:108091



ASSEMBLY INSTRUCTIONS

ASSEMBLY TIPS:

1. Remove hardware from box and sort by size.
2. Please check to see that all hardware and parts are present prior to start of assembly.
3. Please follow attached instructions in the same sequence as numbered to assure fast & easy assembly.



WARNING!

1. Don't attempt to repair or modify parts that are broken or defective. Please contact the store immediately.
2. This product is for home use only and not intended for commercial establishments.



ASSEMBLY TIME 35 MINUTES

PARTS IDENTIFICATION

B1: TOP

A GLASS TOP

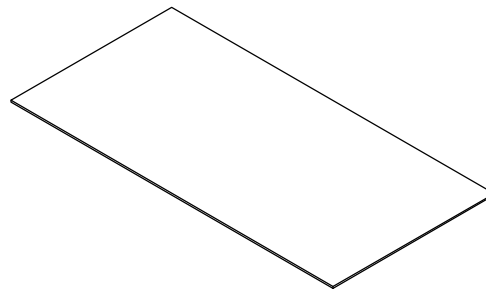

1PC

B2: BASE

B GLASS SIDE

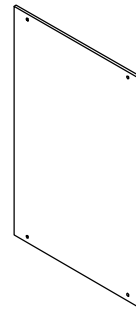

4PCS

C V FRAME

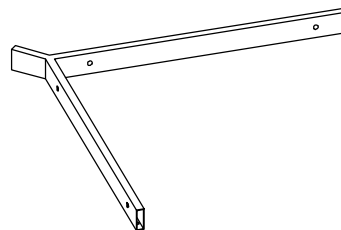

4PCS

D CROSSBAR

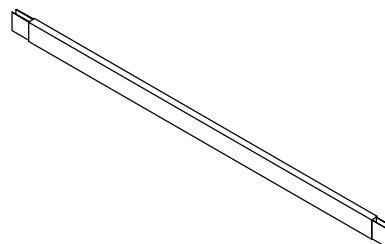







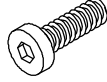

2PCS

ITEM:108091



ASSEMBLY INSTRUCTIONS

Z HARDWARE IDENTIFICATION

1	SHORT BOLT (1/4" x 12mm BLK)		8PCS
2	LONG BOLT (1/4" x 18mm BLK)		16PCS
3	NUT (1/4" BLK)		16PCS
4	CAP (13 x 38mm BLK)		8PCS
5	LEVELER (1/4" x 12mm)		6PCS
6	COVER (Ø11mm BLK)		16PCS
7	WASHER (1/4" BLK)		16PCS
8	SUCTION CUP (12 x 3.5mm)		6PCS
9	ALLEN WRENCH (4mm)		1PC

Hardware pack is located in 108091B2

ITEM:108091



ASSEMBLY INSTRUCTIONS

STEP 1

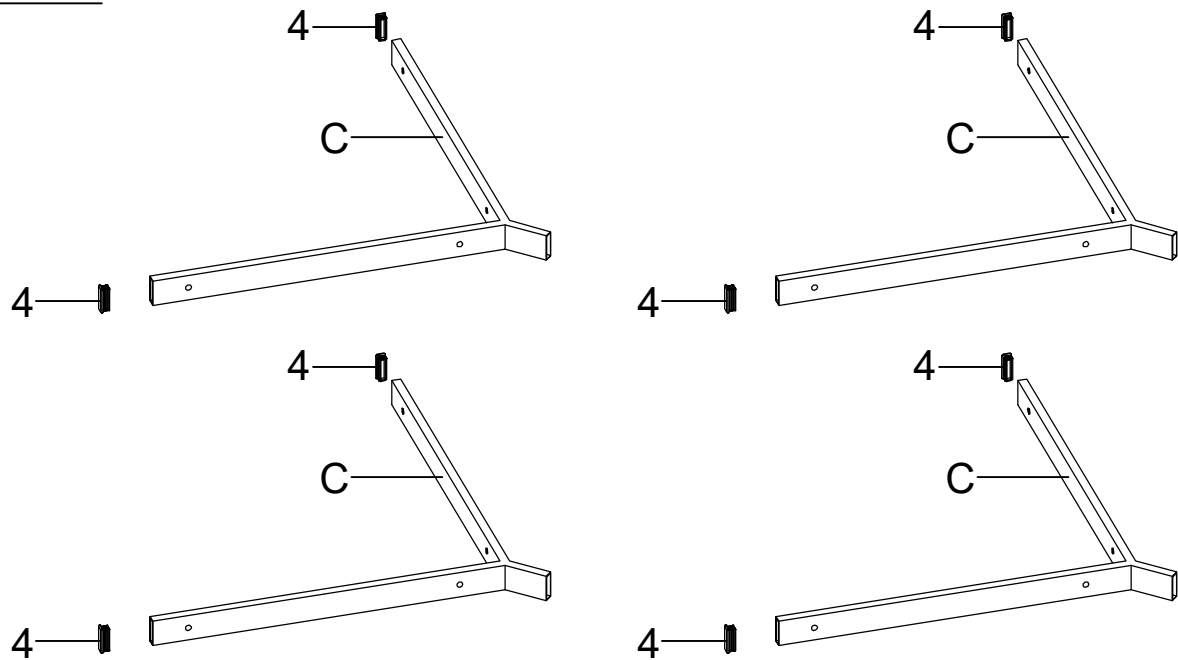

STEP 2

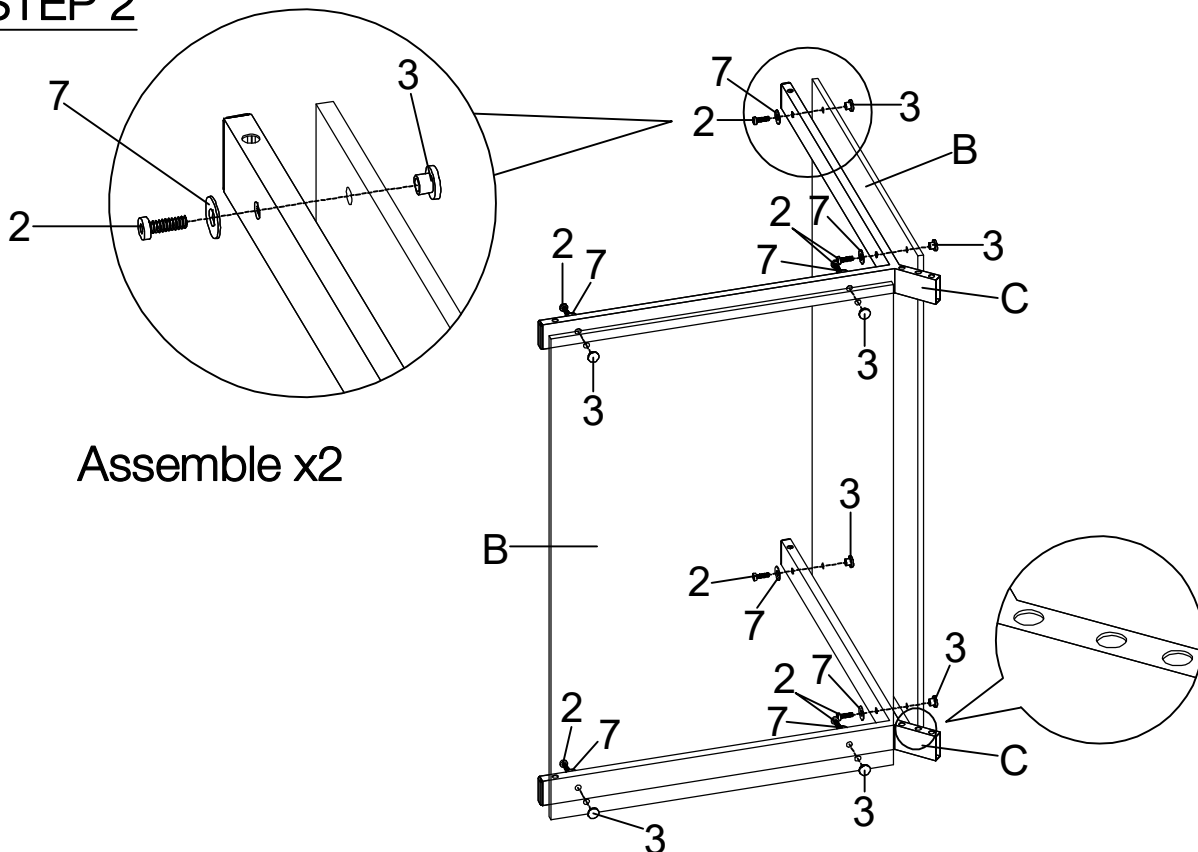

ITEM:108091

ASSEMBLY INSTRUCTIONS

STEP 3

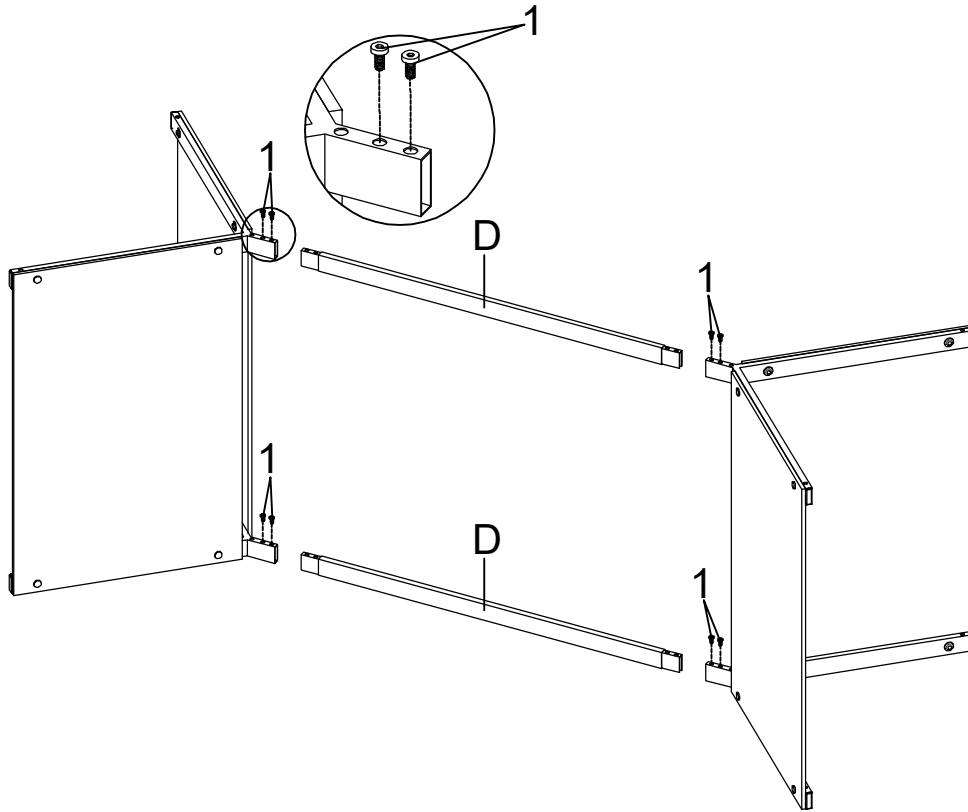

STEP 4

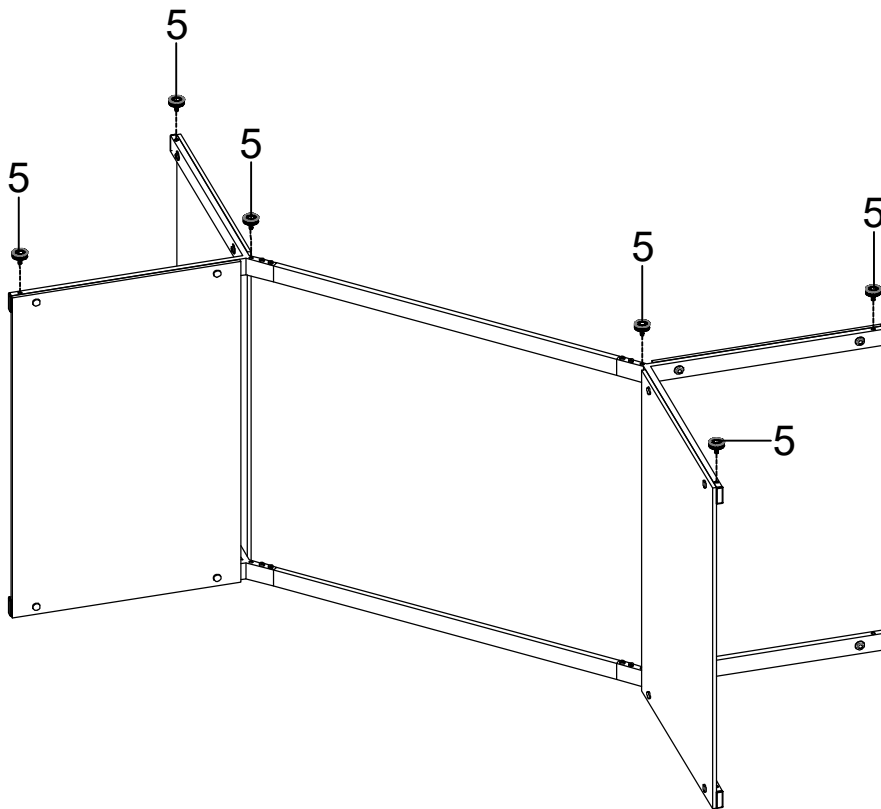

ITEM:108091

ASSEMBLY INSTRUCTIONS

STEP 5

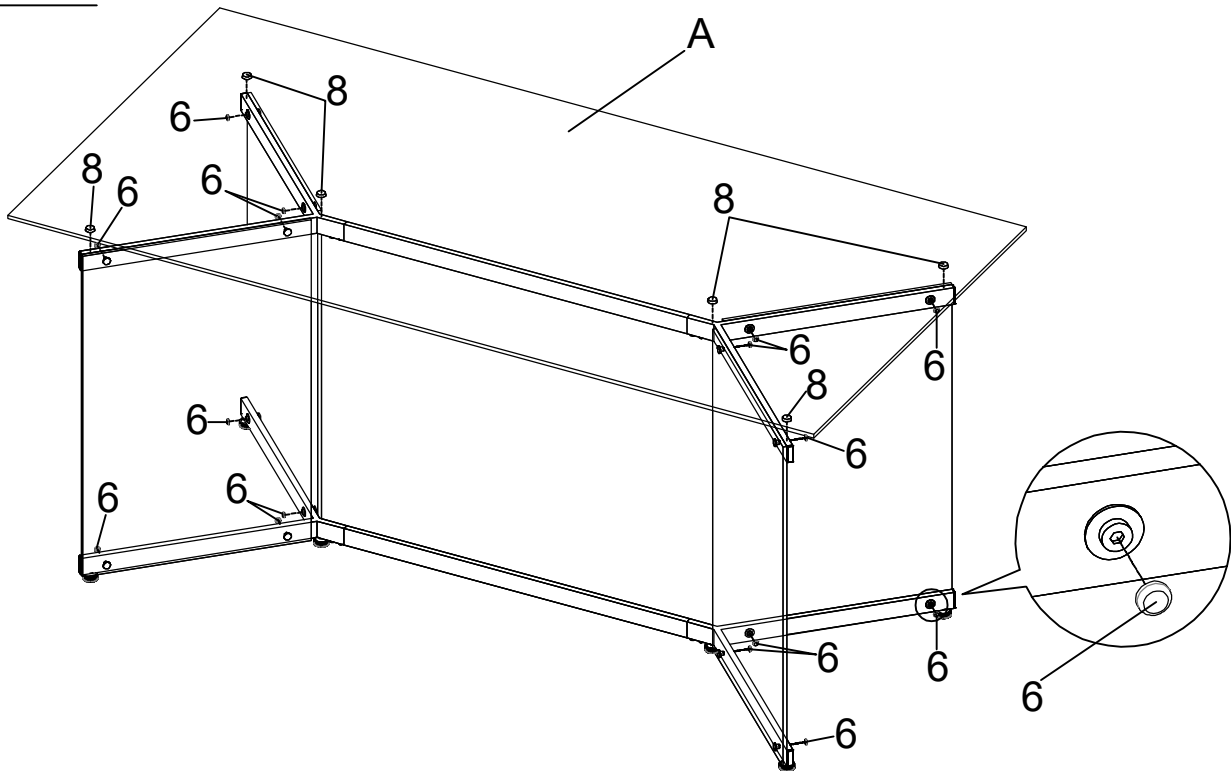

STEP 6 COMPLETE

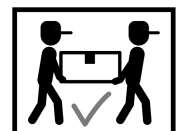
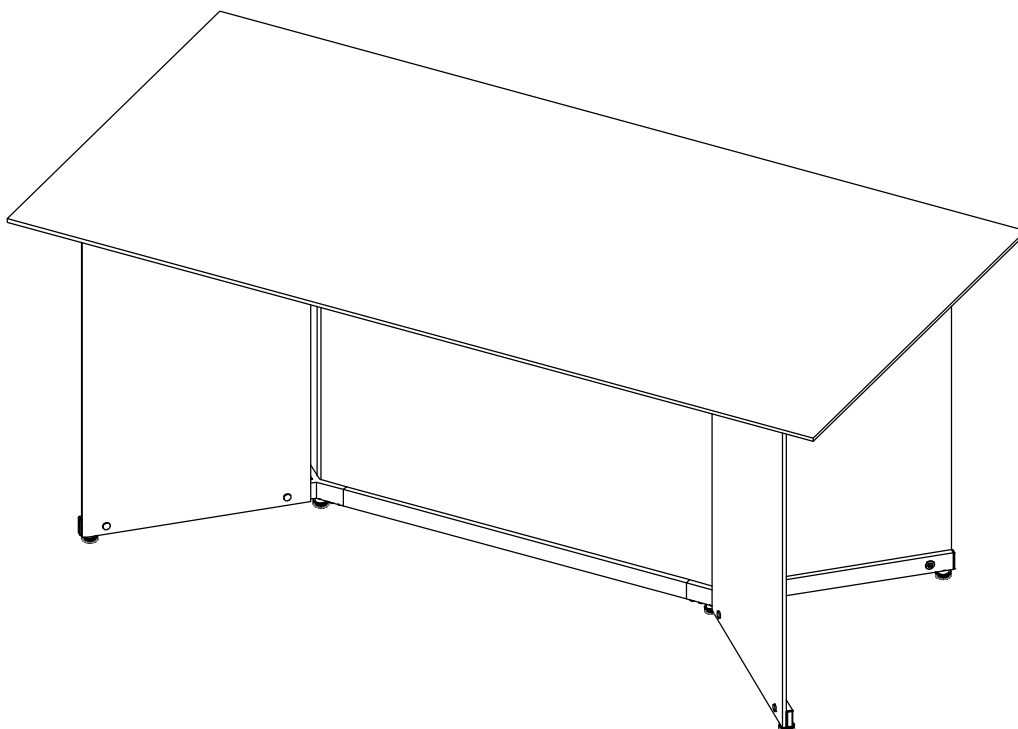

ITEM:108091 ASSEMBLY INSTRUCTIONS



Product Size : 1930 X 959 X 768 H (MM)
Product Size : 76" X 37.75" X 30.25"

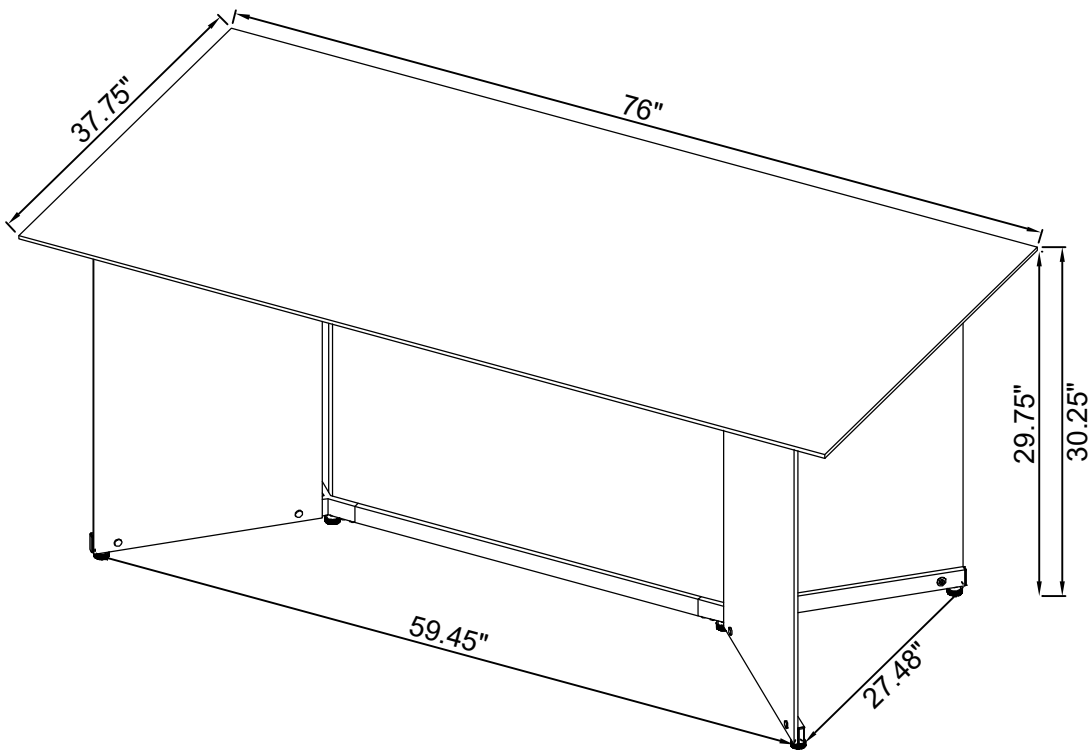

Note : Dimension tolerance $\pm 5\%$