

**ASSEMBLY INSTRUCTIONS**  
**COASTER FINE FURNITURE**



*Fine Furniture for every stage of life*

**980075**  
**BOOKCASE**

ITEM:980075

## ASSEMBLY INSTRUCTIONS

### ASSEMBLY TIPS:

1. Remove hardware from box and sort by size.
2. Please check to see that all hardware and parts are present prior to start of assembly.
3. Please follow attached instructions in the same sequence as numbered to assure fast & easy assembly.



### WARNING!

1. Don't attempt to repair or modify parts that are broken or defective. Please contact the store immediately.
2. This product is for home use only and not intended for commercial establishments.

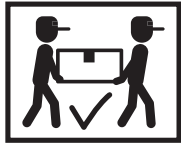

ASSEMBLY TIME

60 MINUTES

## PARTS IDENTIFICATION

A	LEFT SIDE PANEL		1 PC	H	LEFT CROSS PANEL		1 PC
B	RIGHT SIDE PANEL		1 PC	I	SMALL CROSS PANEL		2 PCS
C	SMALL DIVIDER PANEL		2 PCS	J	MIDDLE CROSS PANEL		1 PC
D	LOWER DIVIDER PANEL		1 PC	K	RIGHT CROSS PANEL		1 PC
E	UPPER DIVIDER PANEL		1 PC	L	TOP PANEL		1 PC
F	LEG		2 PCS	M	FRONT TOP BAR		2 PCS
G	BOTTOM PANEL		1 PC	N	BACK PANEL		1 PC

### NOTE:

Phillips head screw driver is required in the assembly process; however, manufacturer does not provide this item.

**HARDWARE IDENTIFICATION**

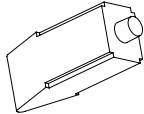
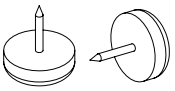
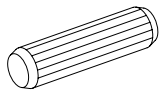
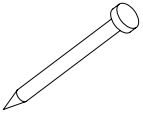
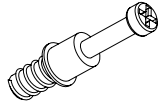
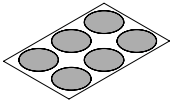
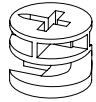
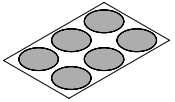
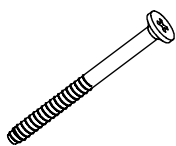
Z							
NO	DESCRIPTION	FIGURE	Q'TY	NO	DESCRIPTION	FIGURE	Q'TY
1	GLUE 40g		1 PC	6	PLASTIC FEET Ø15m		4 PCS
2	WOODEN DOWEL Ø8x30mm		52 PCS	7	NAIL - 3/4" SR		34 PCS
3	CAM BOLT Ø7x35.5mm SR		32 PCS	8	STICKER - WHITE Ø20mm		5 PCS
4	CAM LOCK Ø15x12mm SR		32 PCS	9	STICKER Ø20mm		1 PC
5	BOLT Ø9.5x55mm SR		12 PCS				

**NOTE:**

Phillips head screw driver is required in the assembly process; however, manufacturer does not provide this item.

ITEM: 980075

**COASTER**  
FINE FURNITURE

**STEP 1**

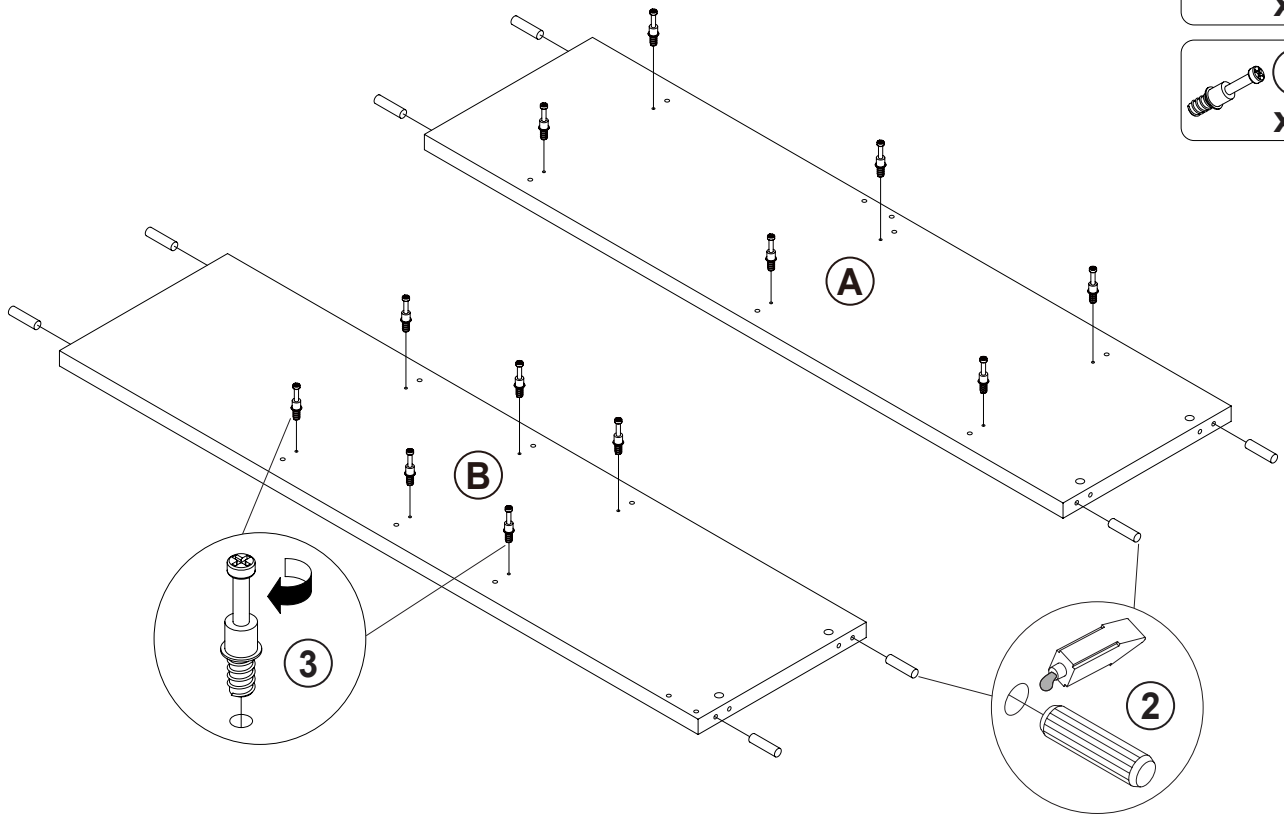

**STEP 2**

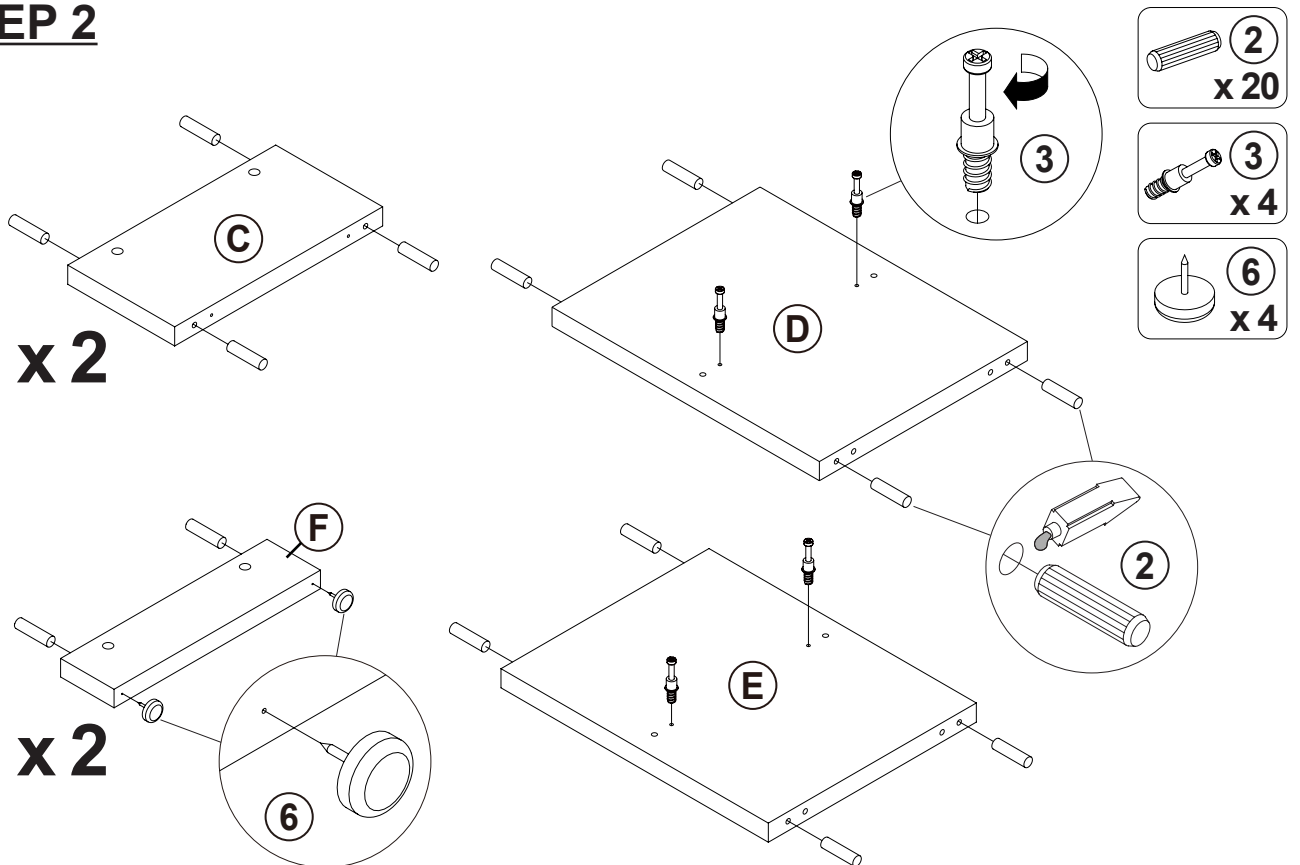

ITEM: 980075

**COASTER**  
FINE FURNITURE

**STEP 3**

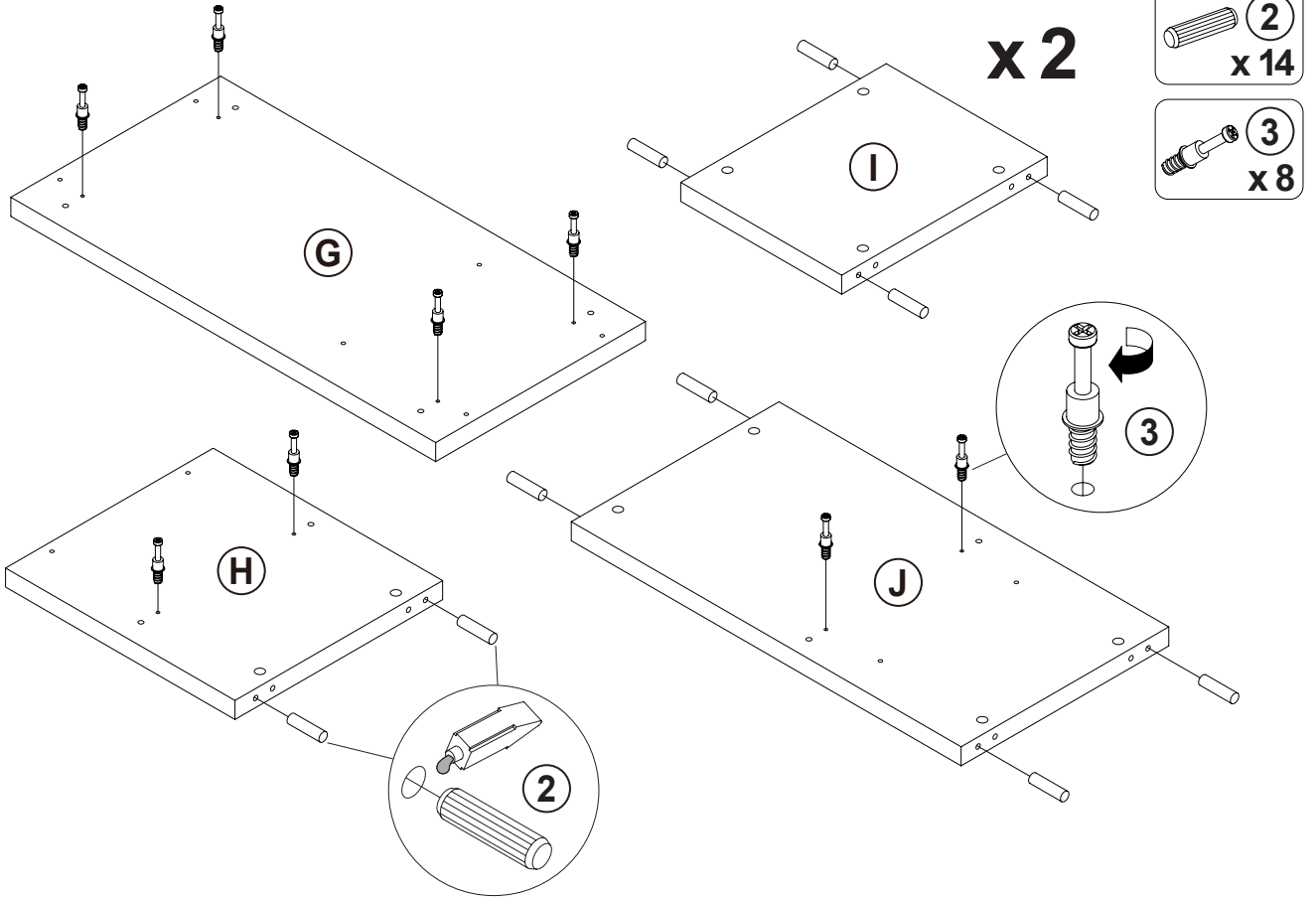

**STEP 4**

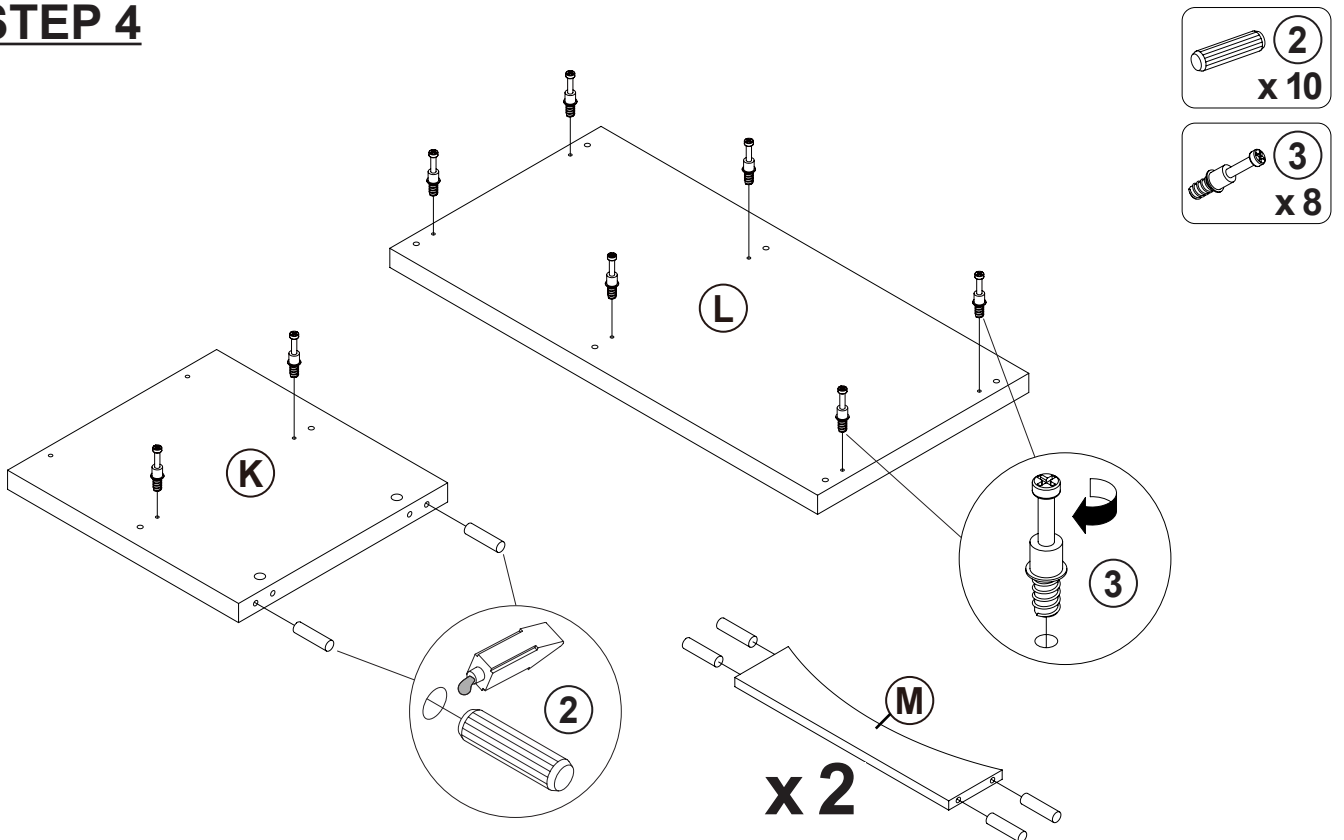

## STEP 5

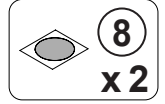
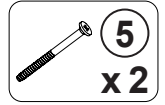
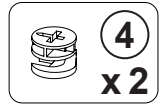
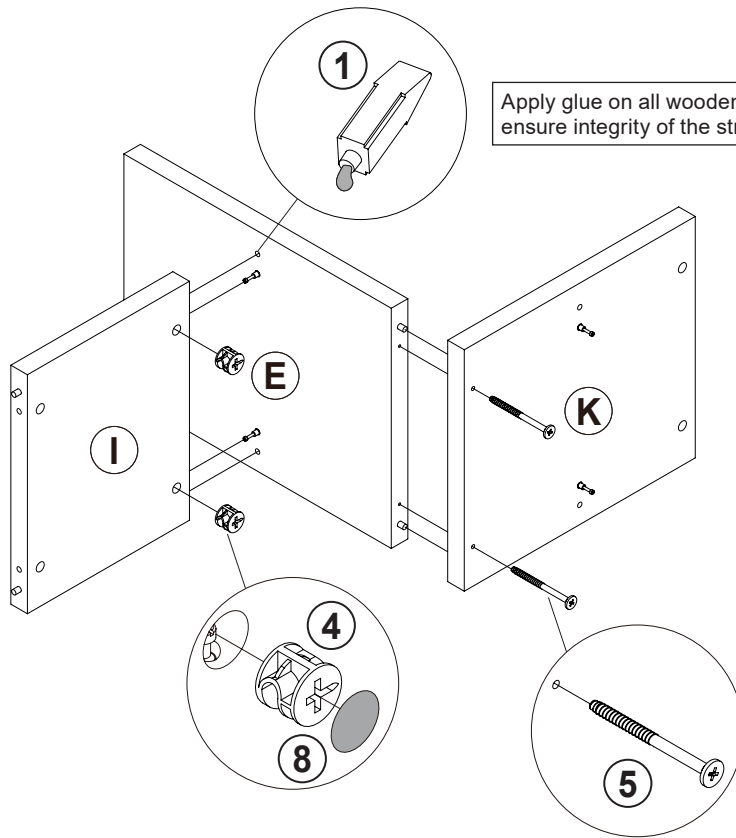
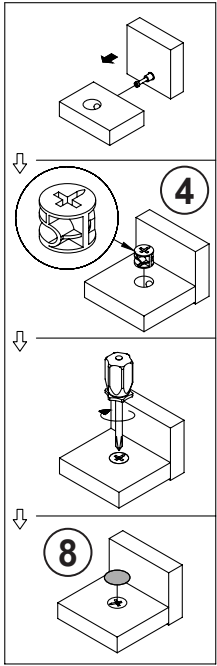
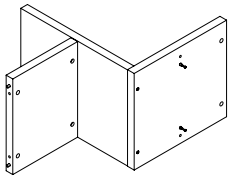

## STEP 6

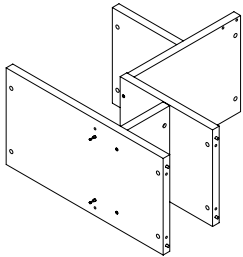

Apply glue on all wooden dowels to ensure integrity of the structure.

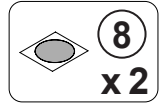
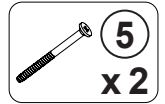
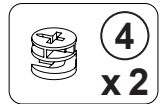
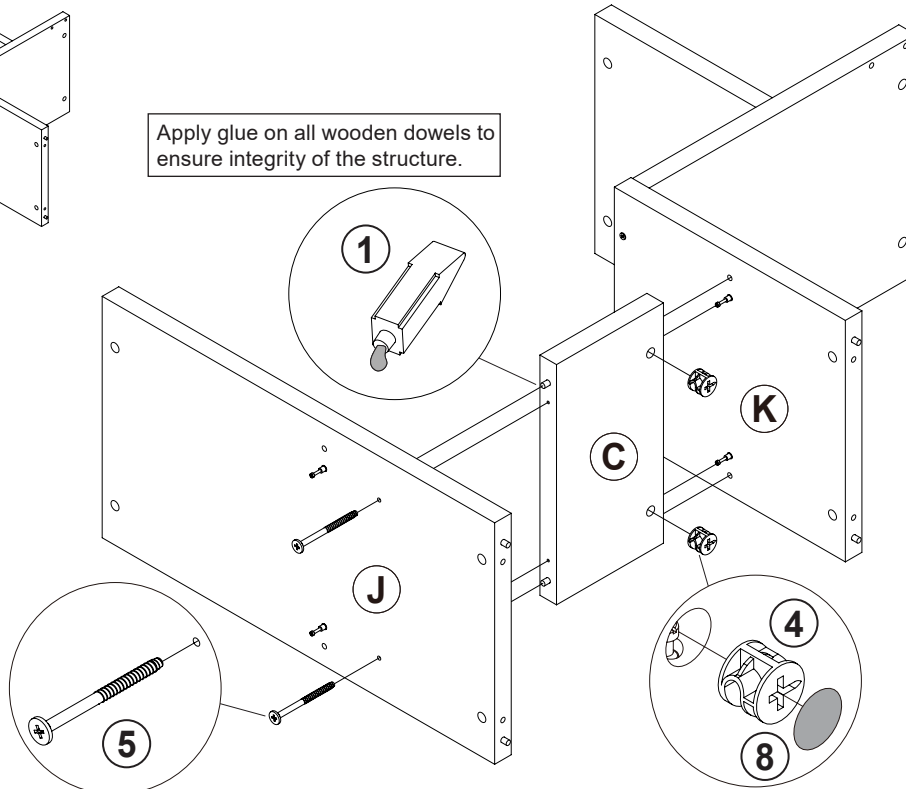

ITEM: 980075

**COASTER**<sup>®</sup>

FINE FURNITURE

**STEP 7**

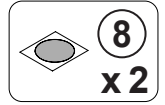
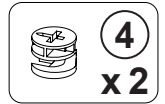
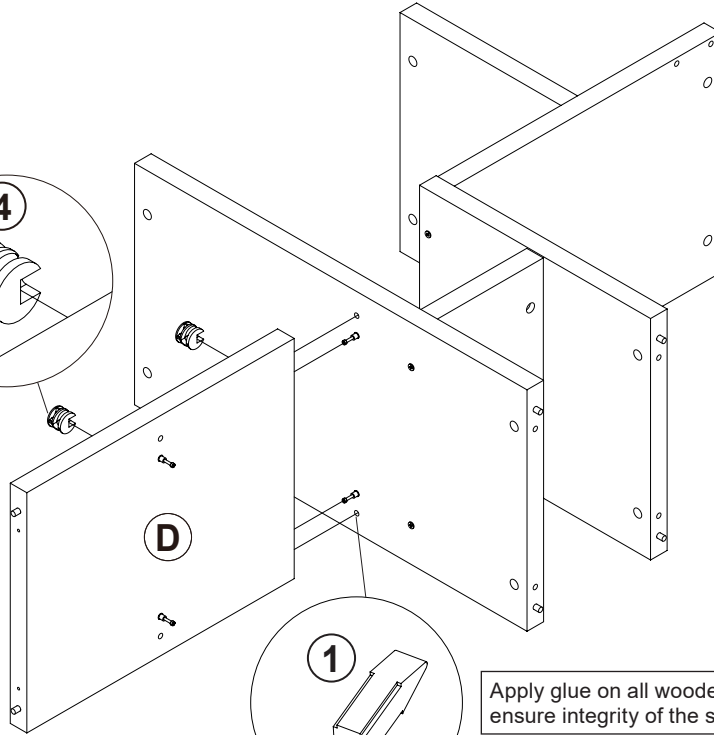
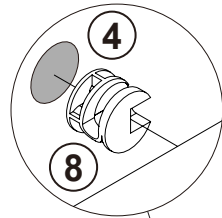
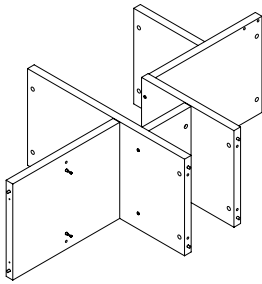

Apply glue on all wooden dowels to ensure integrity of the structure.

**STEP 8**

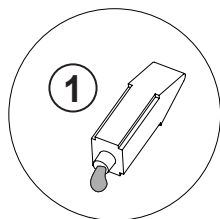
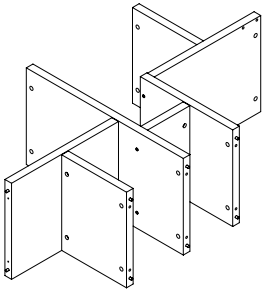

Apply glue on all wooden dowels to ensure integrity of the structure.

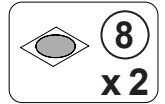
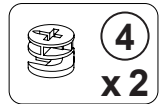
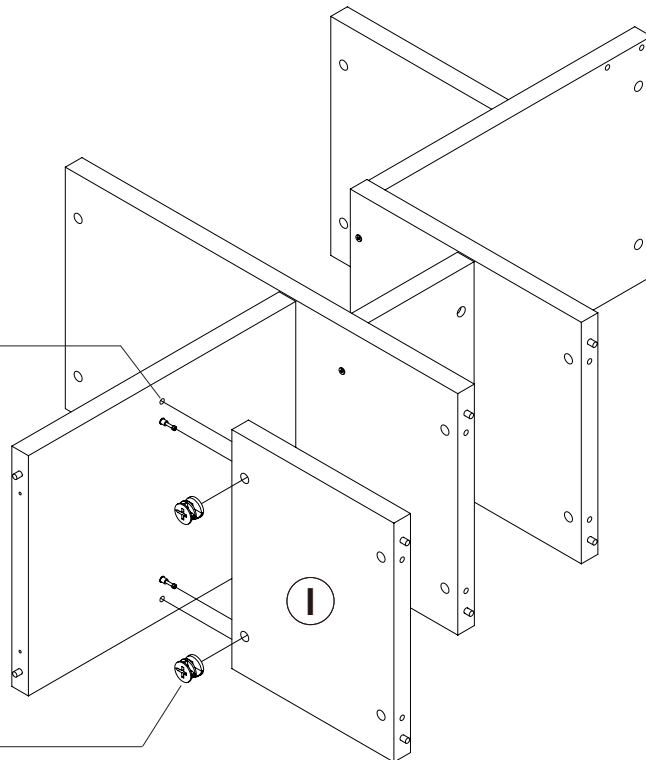

ITEM: **980075**

**COASTER**<sup>®</sup>

FINE FURNITURE

**STEP 9**

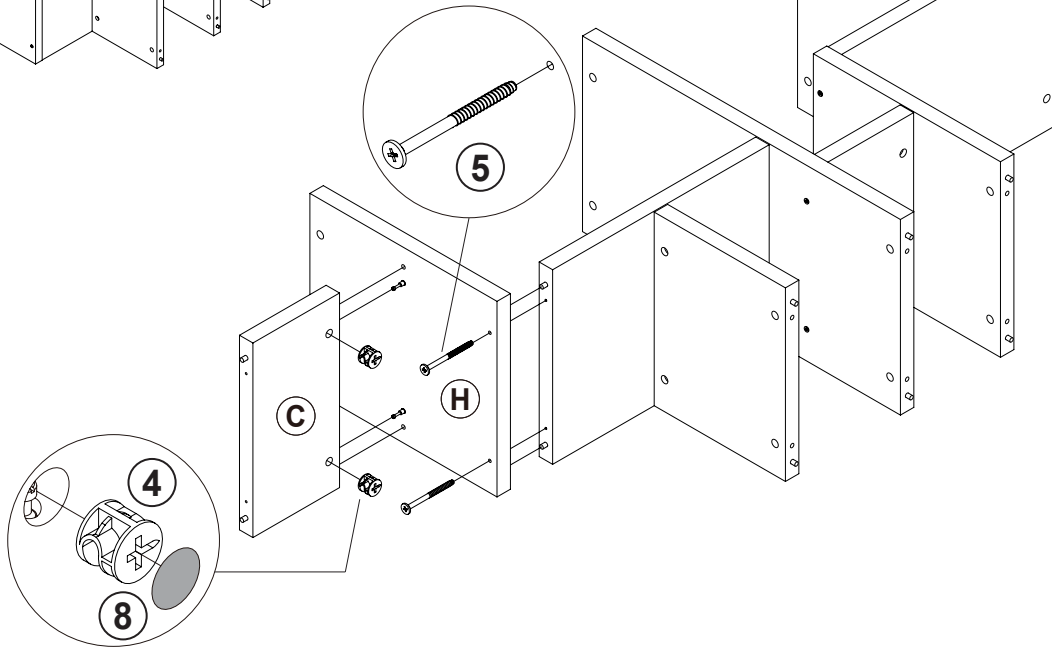
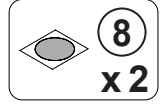
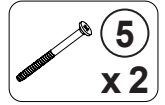
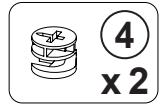
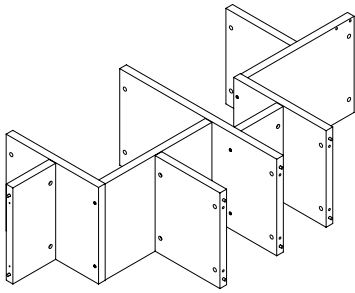

**STEP 10**

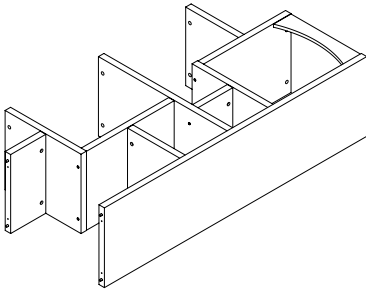

Apply glue on all wooden dowels to ensure integrity of the structure.

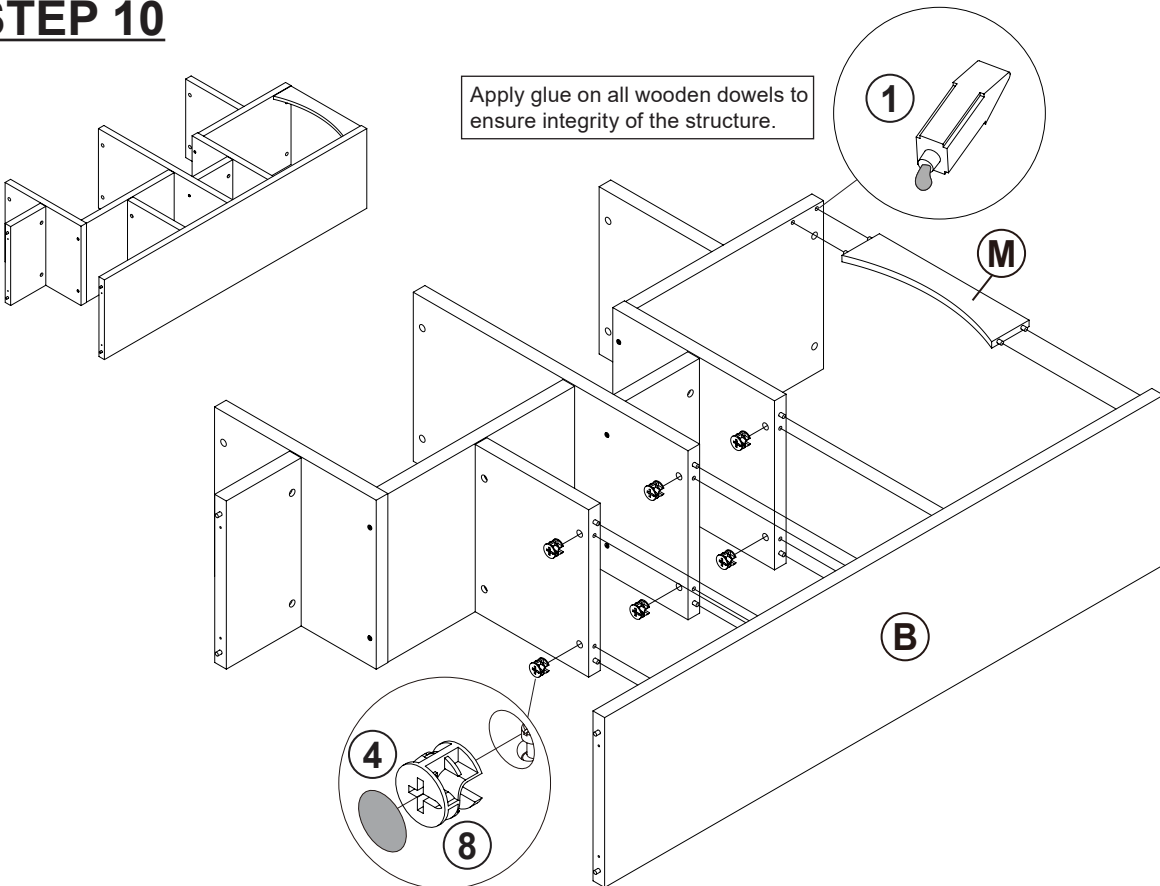
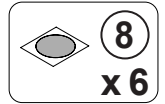
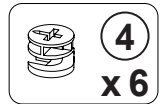



ITEM: 980075

**COASTER**  
FINE FURNITURE

**STEP 11**

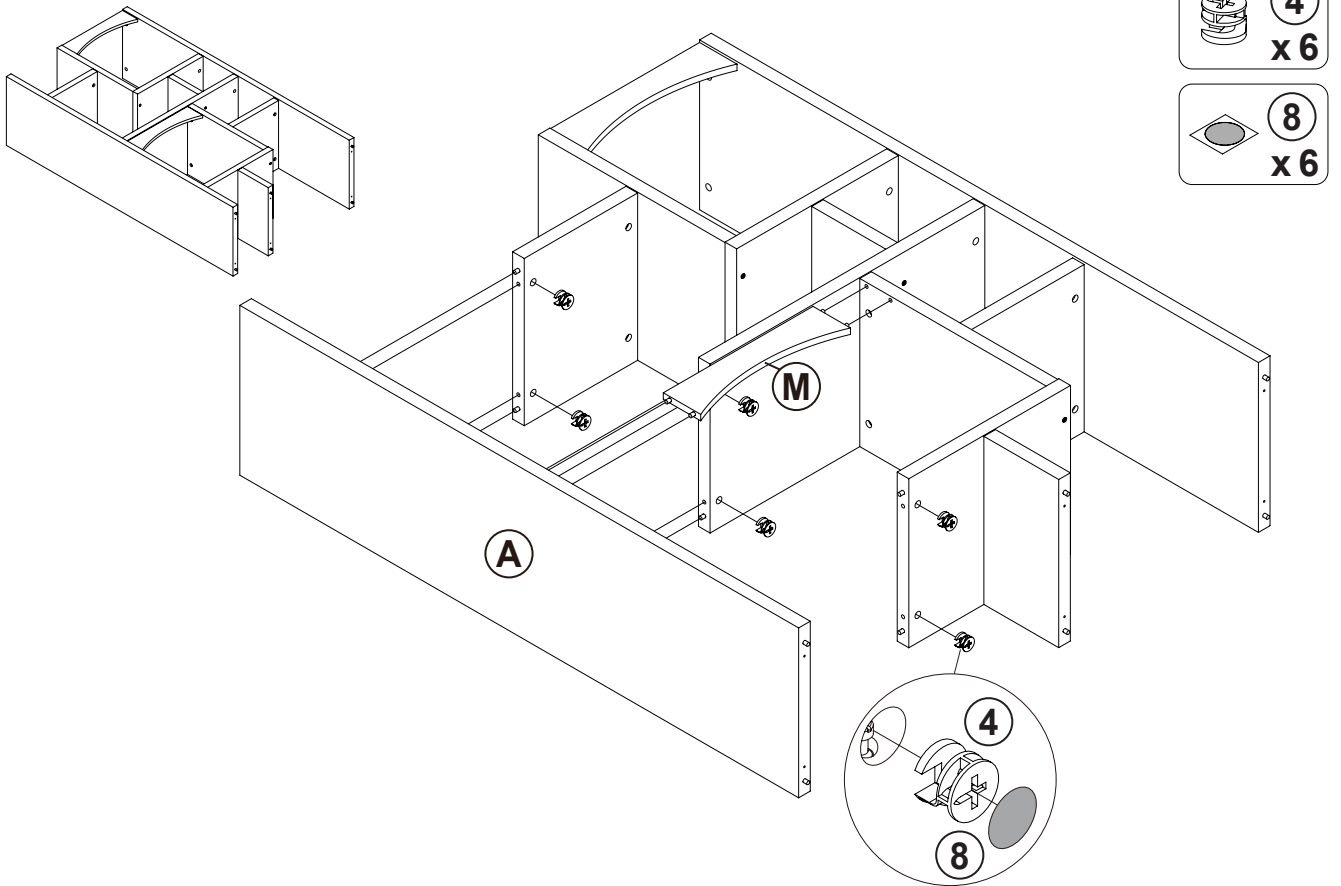

**STEP 12**

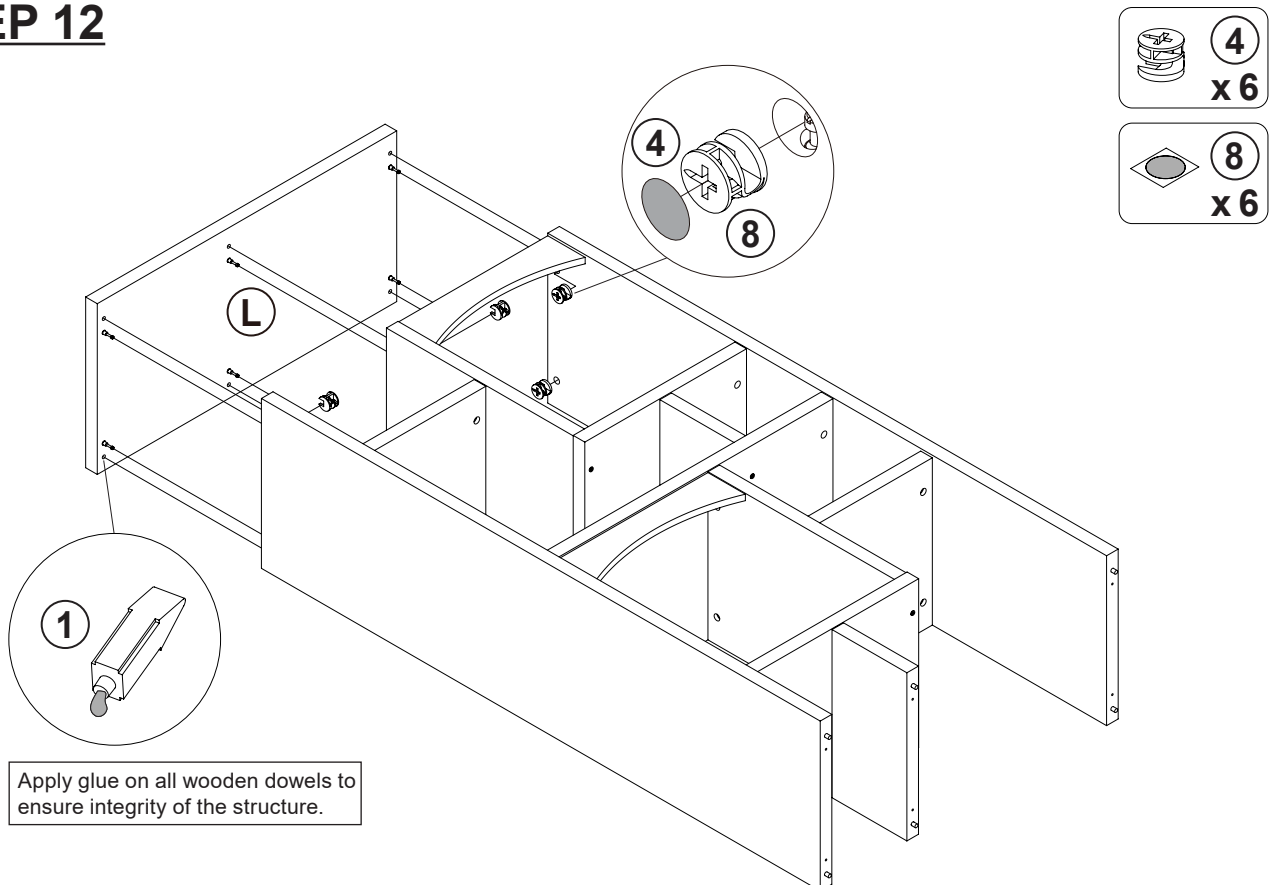

Apply glue on all wooden dowels to ensure integrity of the structure.

ITEM: **980075**

**COASTER**<sup>®</sup>

FINE FURNITURE

**STEP 13**

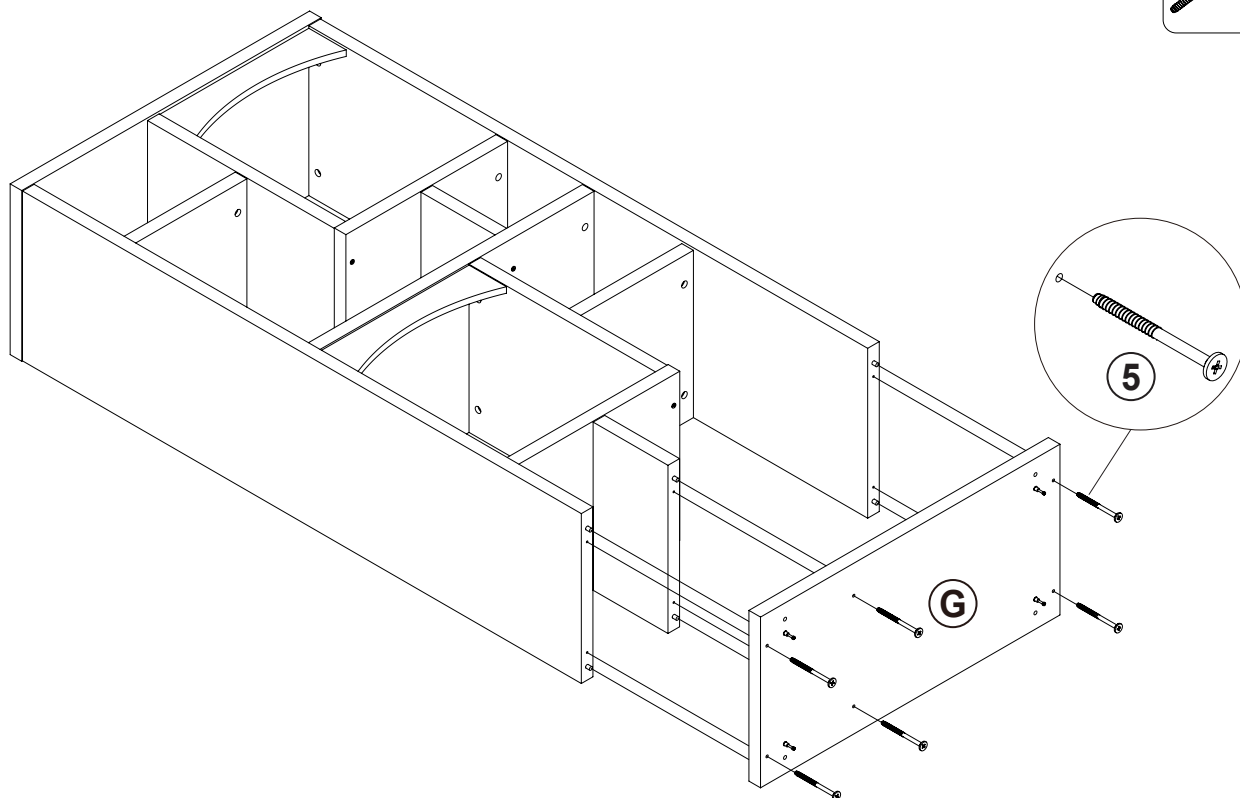
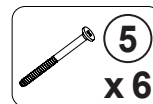

**STEP 14**

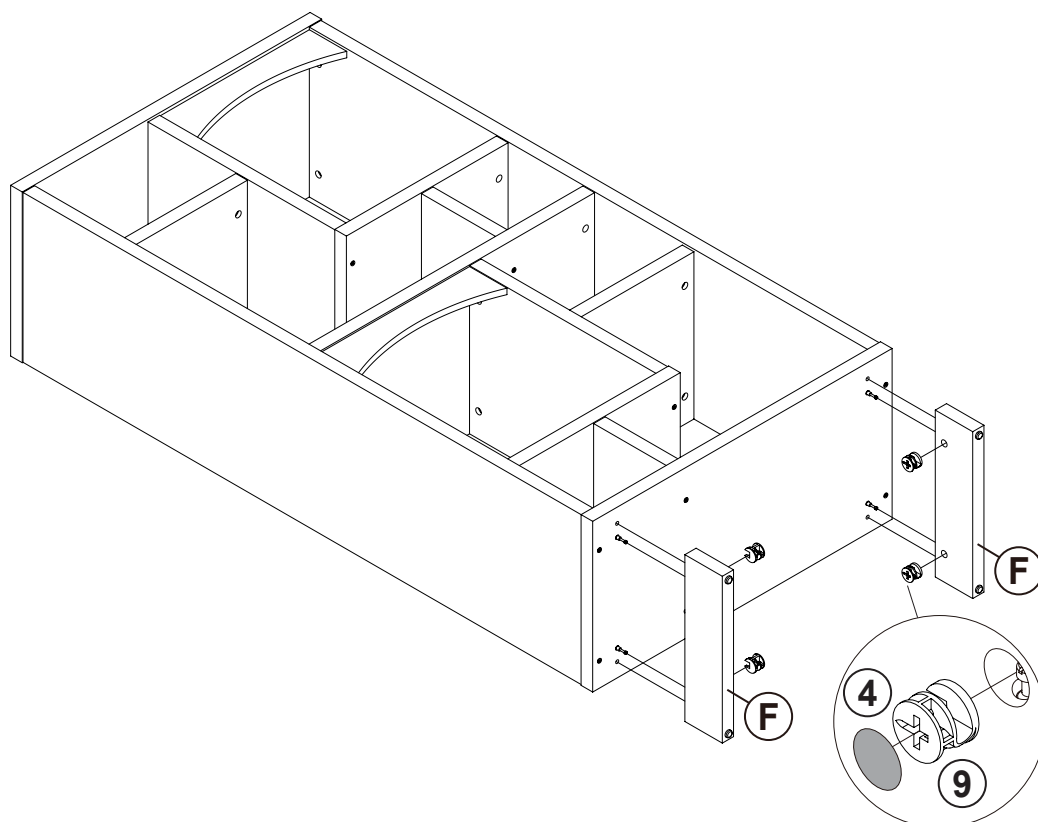
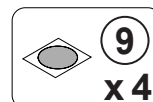

ITEM: **980075**

**COASTER**<sup>®</sup>

FINE FURNITURE

**STEP 15**

**7**  
x 34

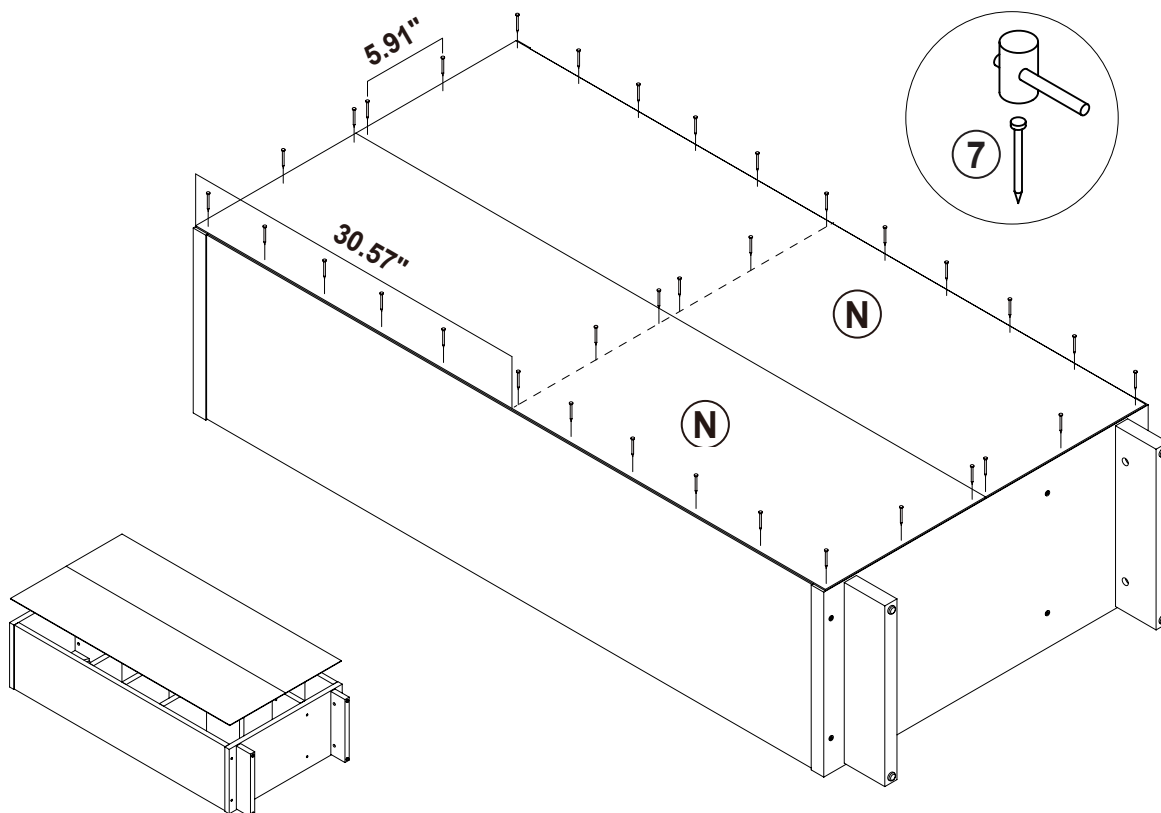

**STEP 16**

**COMPLETE**

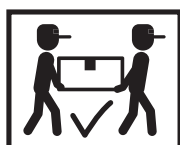
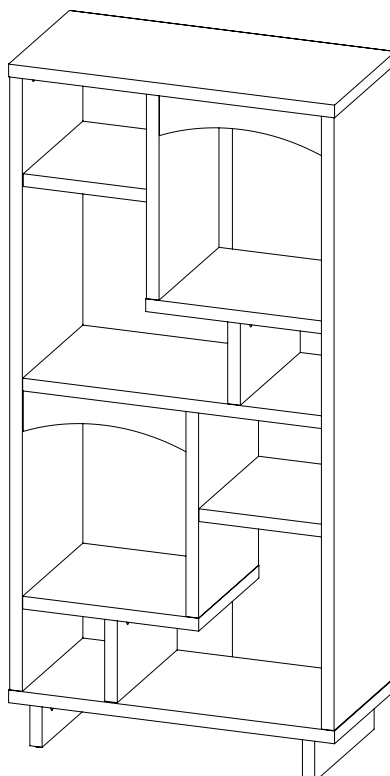



## ANTI-TIPPING INSTALLMENT INSTRUCTIONS FURNITURE TIPPING RESTRAINT

### WARNING

Injury may result from tipping furniture.  
This restraint may protect against tipping furniture.  
Do not allow children to climb on furniture.  
This restraint is not a substitute for proper adult supervision.  
Failure to detach this restraint before moving the furniture may result in injury and damage.

This restraint must be screwed to a wood stud on the wall, using the long screw provided.

### STEP 1

Secure the bracket to the back top of the unit, using the short screw provided, as shown in the drawing.

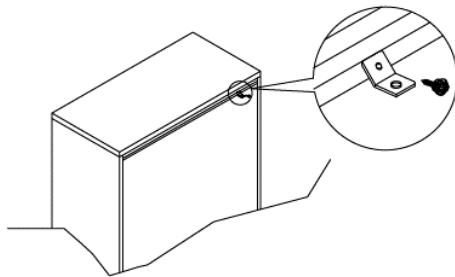

### STEP 2

Locate the wood stud on the wall, and secure the other bracket, 2 inches below the back of the unit.

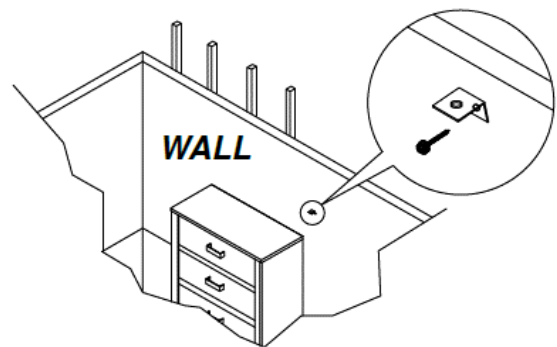

### STEP 3

Place the furniture into position so both mounting brackets are vertically in line. Lace the end of the restraint strap through the larger hole in each mounting bracket. Bring both ends together and slide the flat end through the locking end, and drag it through, until the slack is removed. Ensure that the strap is securely laced and locked.

