

**ASSEMBLY INSTRUCTIONS**  
**COASTER FINE FURNITURE**

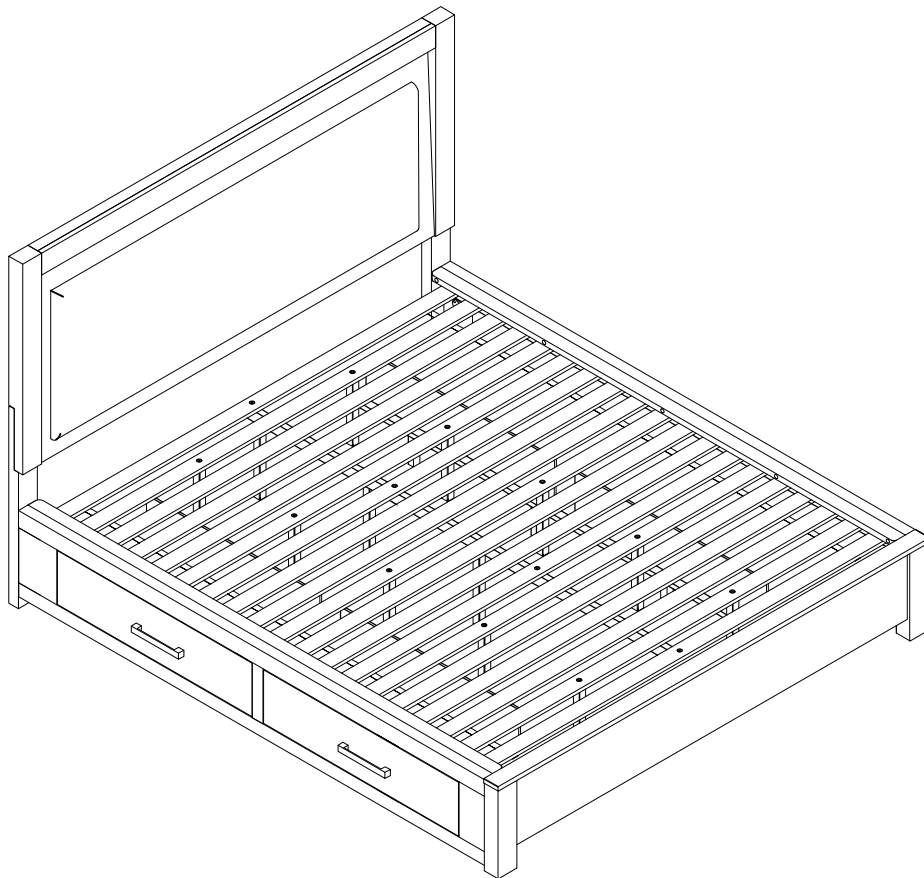

*Fine Furniture for every stage of life*

**224850KW(B1-B3)**  
**California King bed**

# ITEM: 224850KW(B1-B3)



## ASSEMBLY INSTRUCTIONS

### ASSEMBLY TIPS:

1. Remove hardware from box and sort by size.
2. Please check to see that all hardware and parts are present prior to start of assembly.
3. Please follow attached instructions in the same sequence as numbered to assure fast & easy assembly.



### WARNING!

1. Don't attempt to repair or modify parts that are broken or defective. Please contact the store immediately.
2. This product is for home use only and not intended for commercial establishments.





ASSEMBLY TIME





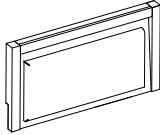

25 MINUTES

## PARTS IDENTIFICATION

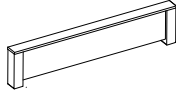
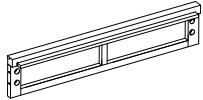

### B1 (BOX 1)

A	HEADBOARD PANEL		1PC	B	LEFT HEADBOARD LEG		1PC
C	RIGHT HEADBOARD LEG		1PC				

### B2 (BOX 2)

D	FOOTBOARD		1PC	E	BED RAIL		2PCS
F	RAIL TOP		2PCS	G	ROLL SLAT (19PCS)		1SET
H	ROLL SLAT SUPPORT WITH LEVELER		10PCS	I	CENTER RAIL		1PC
J	CENTER RAIL SUPPORT WITH LEVELER		4PCS				

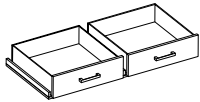
### B3 (BOX 3)

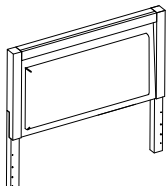
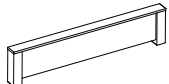
K	DRAWERS		2SETS	L	DRAWERS SUPPORT LEG WITH LEVELER		6PCS
HB	224850KW (B1) FROM BOX 1 HEADBOARD COMPLETE		1PC	D	224850KW (B2) FROM BOX 2 FOOTBOARD		1PC

# ITEM: 224850KW(B1-B3)



## ASSEMBLY INSTRUCTIONS

### ASSEMBLY TIPS:

1. Remove hardware from box and sort by size.
2. Please check to see that all hardware and parts are present prior to start of assembly.
3. Please follow attached instructions in the same sequence as numbered to assure fast & easy assembly.







### WARNING!









1. Don't attempt to repair or modify parts that are broken or defective. Please contact the store immediately.
2. This product is for home use only and not intended for commercial establishments.

## HARDWARE IDENTIFICATION

### Z-B1 (BOX 1) - HARDWARE PACK IS LOCATED IN 224850KW(B1)

1	<b>MEDIUM BOLT</b> (Φ5/16" x 45MM - BLK)		6PCS
2	<b>BIG LOCK WASHER</b> (Φ5/16" x 12 x 2MM - BLK)		6PCS
3	<b>BIG FLAT WASHER</b> (Φ5/16" x 19 x 2MM - BLK)		6PCS
4	<b>ALLEN WRENCH</b> (M4 x 58MM - BLK)		1PC

### Z-B2 (BOX 2) - HARDWARE PACK IS LOCATED IN 224850KW(B2)

5	<b>SHORT WOODEN DOWEL</b> (Φ8 x 30MM)		4PCS
6	<b>LONG WOODEN DOWEL</b> (Φ10 x 40MM)		8PCS
7	<b>SHORT BOLT</b> (Φ1/4" x 32MM - BLK)		12PCS
8	<b>SMALL LOCK WASHER</b> (Φ1/4" x 10 x 2MM - BLK)		12PCS
9	<b>SMALL FLAT WASHER</b> (Φ1/4" x 19 x 2MM - BLK)		12PCS
10	<b>LONG BOLT</b> (Φ1/4" x 45MM - BLK)		10PCS
8	<b>SMALL LOCK WASHER</b> (Φ1/4" x 10 x 2MM - BLK)		10PCS
11	<b>SMALL FLAT WASHER</b> (Φ1/4" x 16 x 2MM - BLK)		10PCS
4	<b>ALLEN WRENCH</b> (M4 x 58MM - BLK)		1PC

# ITEM: 224850KW(B1-B3)



## ASSEMBLY INSTRUCTIONS

### ASSEMBLY TIPS:





1. Remove hardware from box and sort by size.
2. Please check to see that all hardware and parts are present prior to start of assembly.
3. Please follow attached instructions in the same sequence as numbered to assure fast & easy assembly.







### WARNING!

1. Don't attempt to repair or modify parts that are broken or defective. Please contact the store immediately.
2. This product is for home use only and not intended for commercial establishments.

## HARDWARE IDENTIFICATION

12	<b>THREADED BOLT</b> (Ø5/16" x 90MM - BLK)		8PCS
13	<b>HALF ROUND NUT</b> (26 x 12 x 8MM - BLK)		8PCS
14	<b>HEX NUT</b> (Ø5/16 x 6MM - BLK)		8PCS
15	<b>WRENCH</b> (12MM - BLK)		1PC

## Z-B3 (BOX 3) - HARDWARE PACK IS LOCATED IN 224850KW(B3)

5	<b>WOODEN DOWEL</b> (Ø8 x 30MM)		4PCS
16	<b>LONG BOLT</b> (Ø5/16" x 65MM - BLK)		8PCS
2	<b>BIG LOCK WASHER</b> (Ø5/16" x 12 x 2MM - BLK)		8PCS
3	<b>BIG FLAT WASHER</b> (Ø5/16" x 19 x 2MM - BLK)		8PCS
4	<b>ALLEN WRENCH</b> (M4 x 58MM - BLK)		1PC

### NOTE:

Philips head screw driver is required in the assembly process; however, manufacturer does not provide this item.

ITEM: **224850KW(B1-B3)**



**ASSEMBLY INSTRUCTIONS**

**STEP 1**

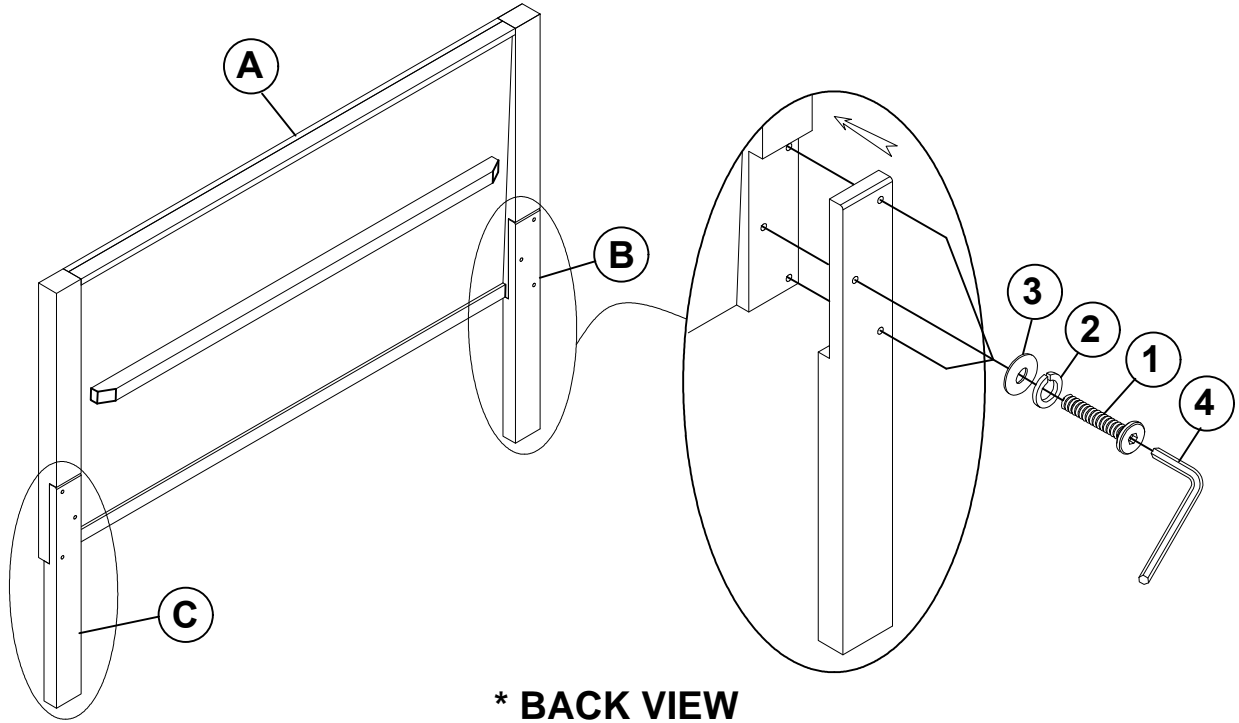

**STEP 2**

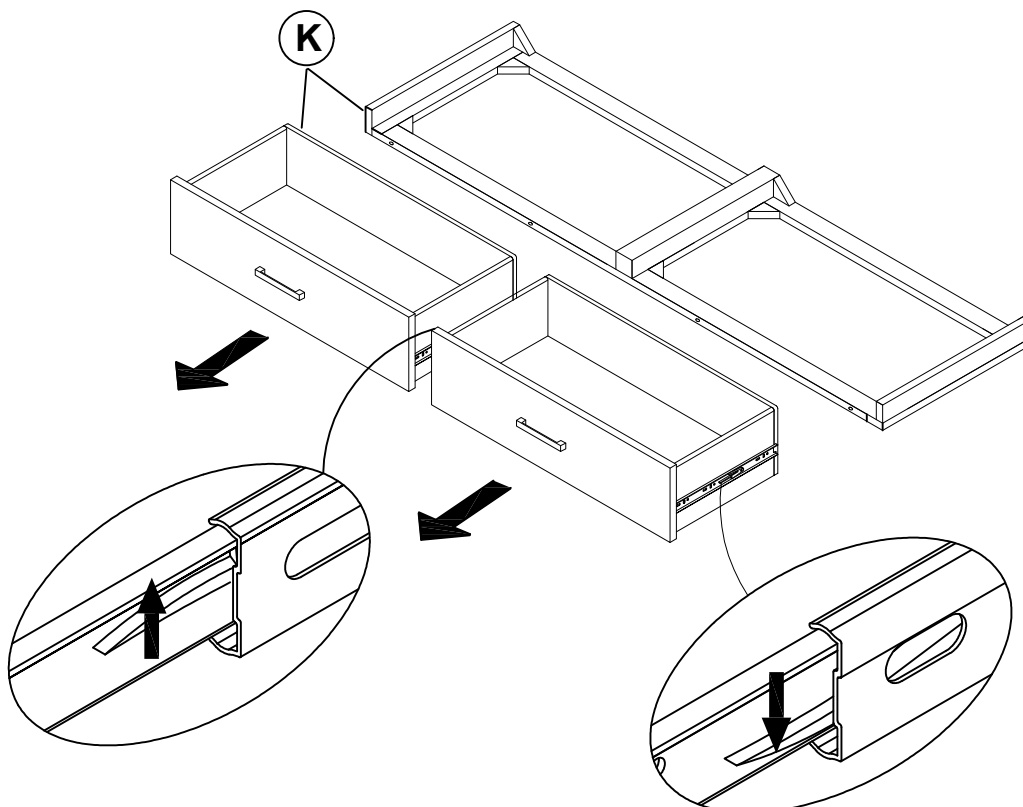

ITEM: **224850KW(B1-B3)**



**ASSEMBLY INSTRUCTIONS**

**STEP 3**

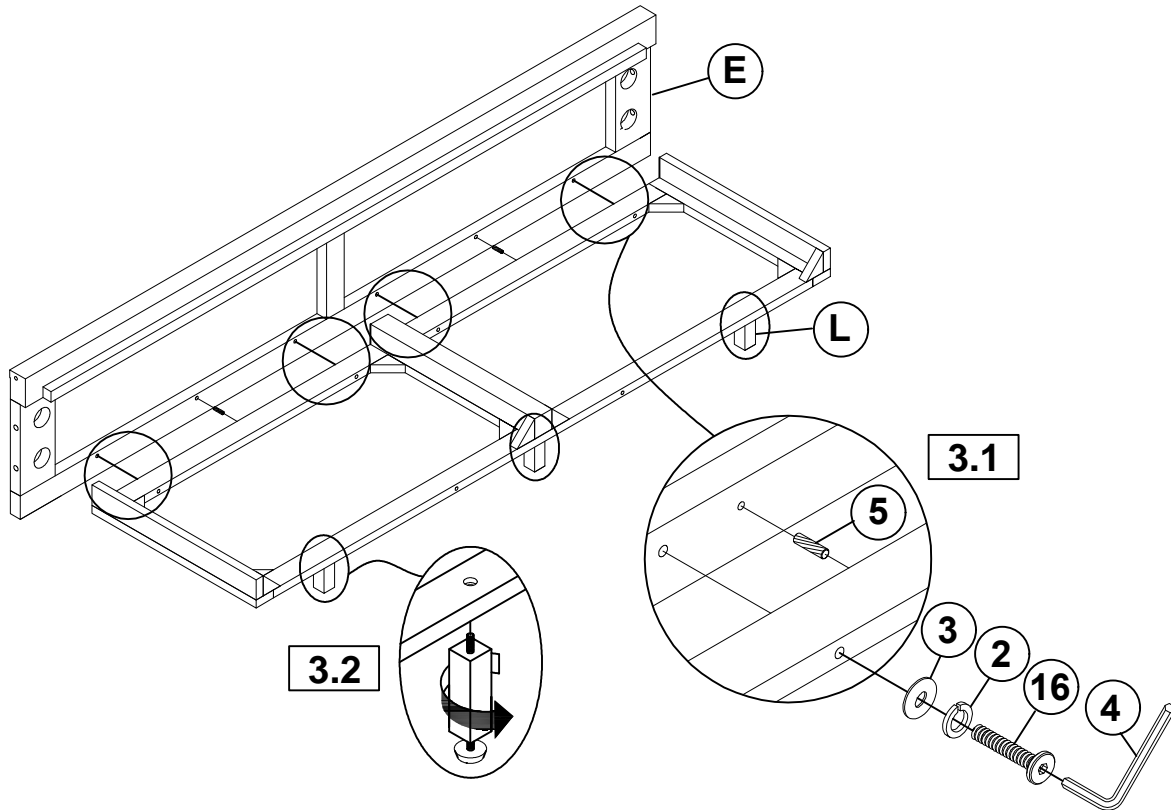

**STEP 4**

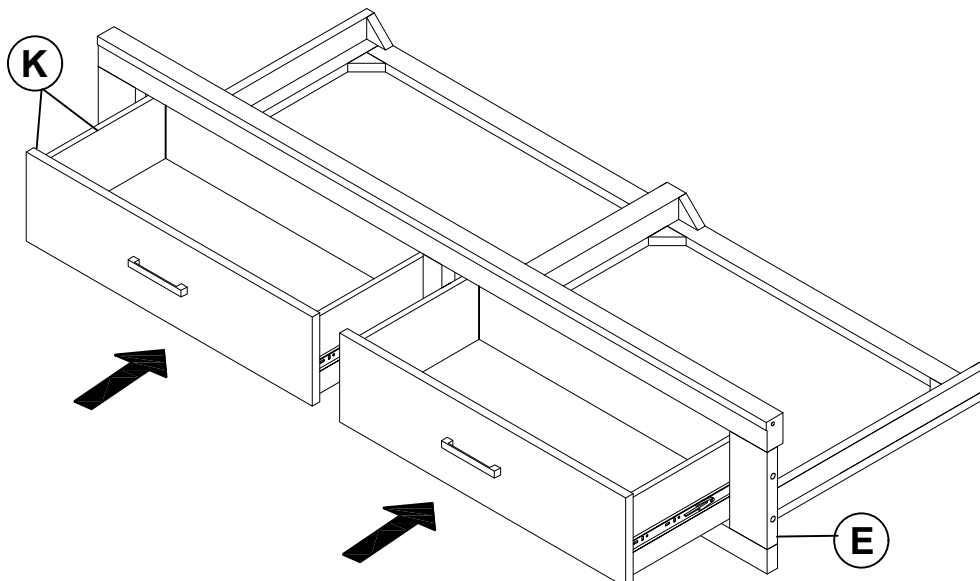

# ITEM: 224850KW(B1-B3)



## ASSEMBLY INSTRUCTIONS

### STEP 5

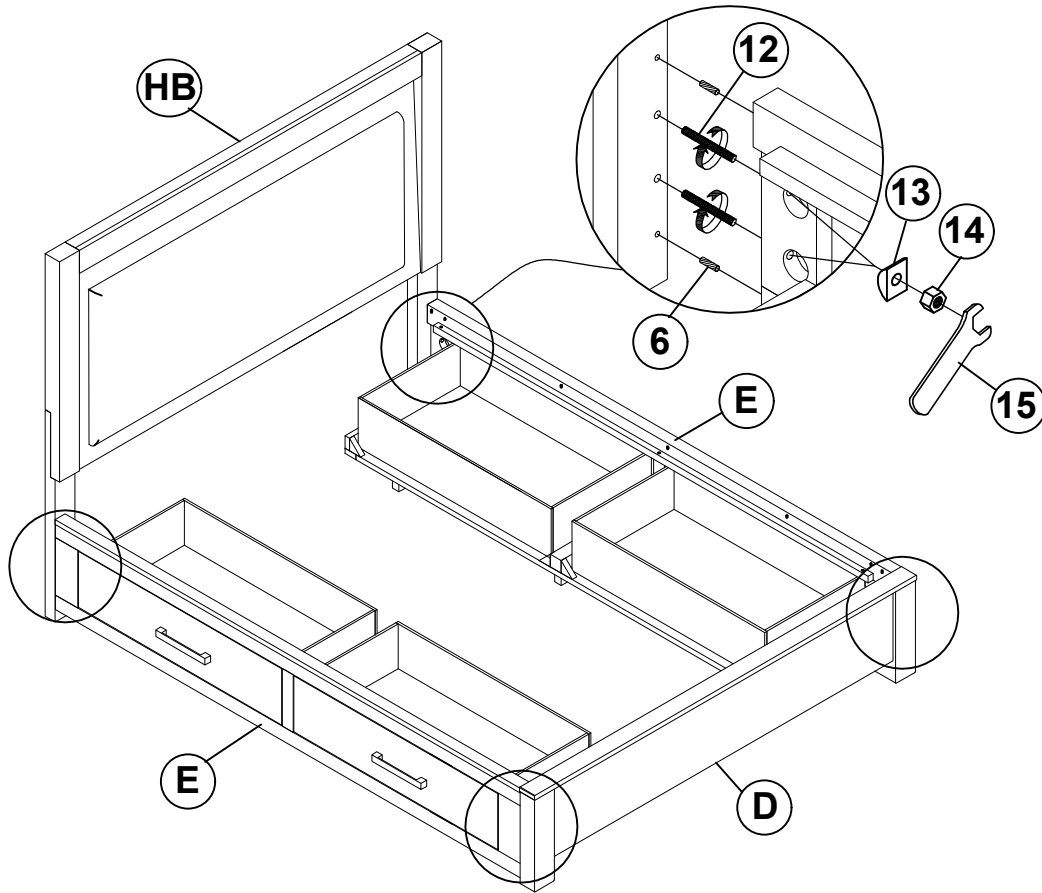

### STEP 6

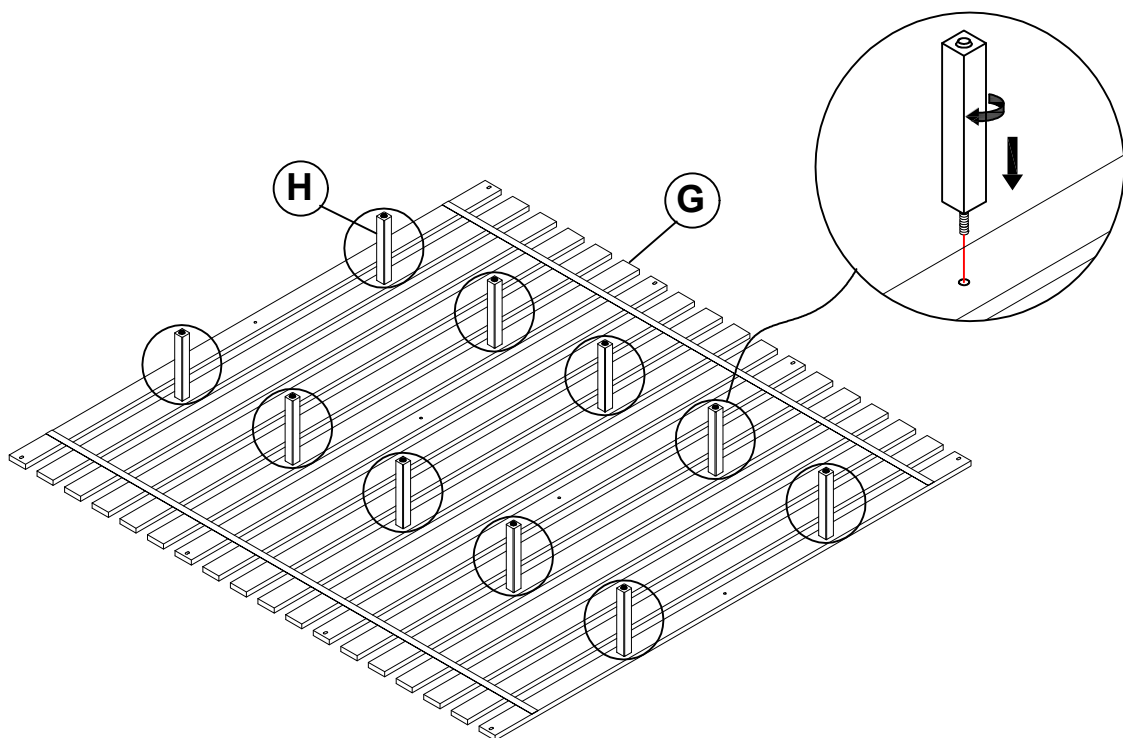

# ITEM: 224850KW(B1-B3)

## ASSEMBLY INSTRUCTIONS

### STEP 7

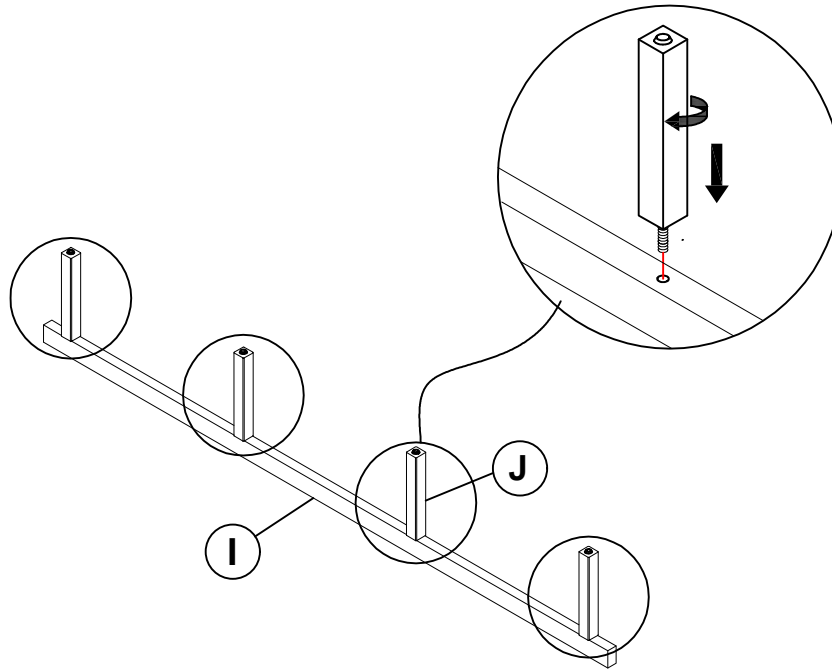

### STEP 8

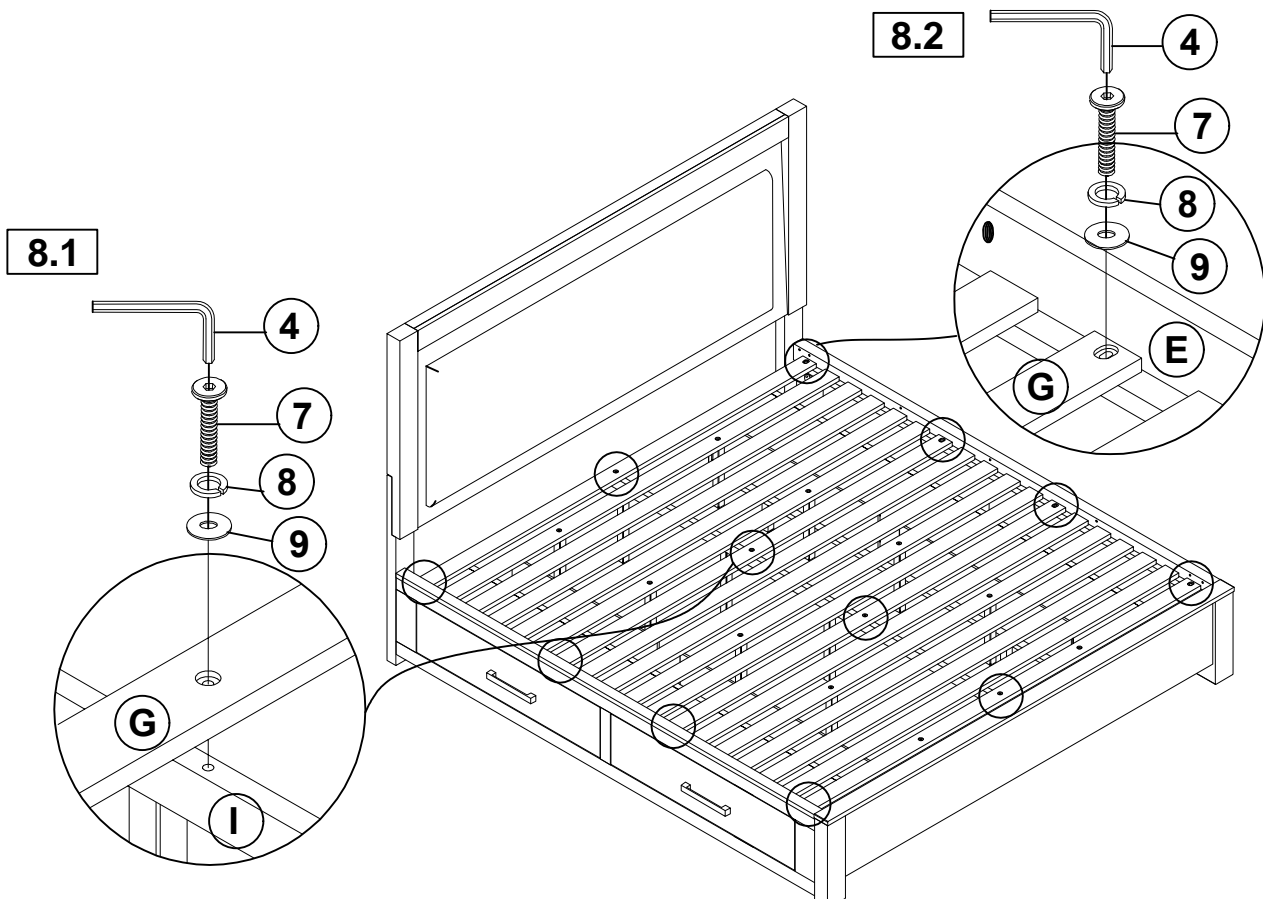



ITEM: **224850KW(B1-B3)**



**ASSEMBLY INSTRUCTIONS**

**STEP 9**

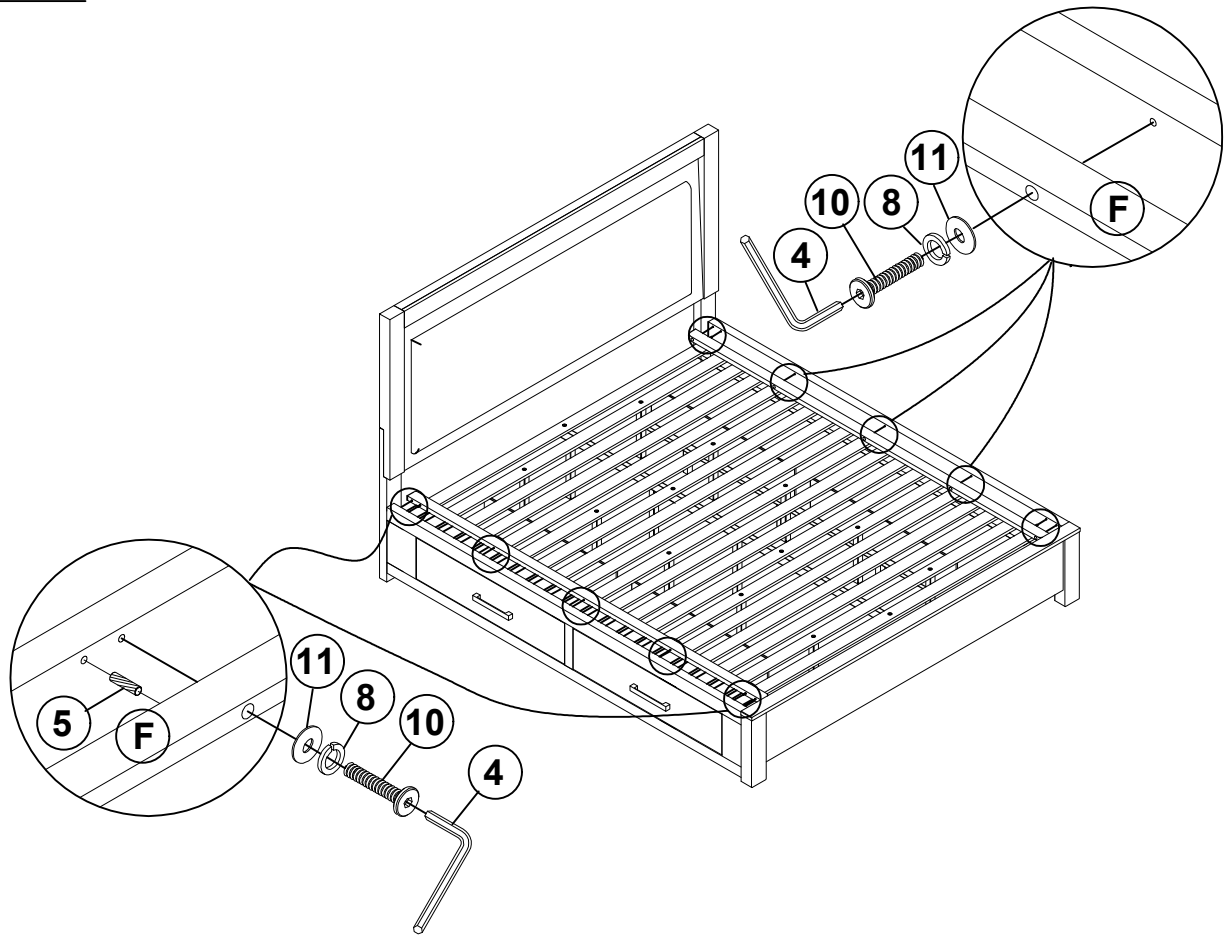

**STEP 10**  
**COMPLETE**

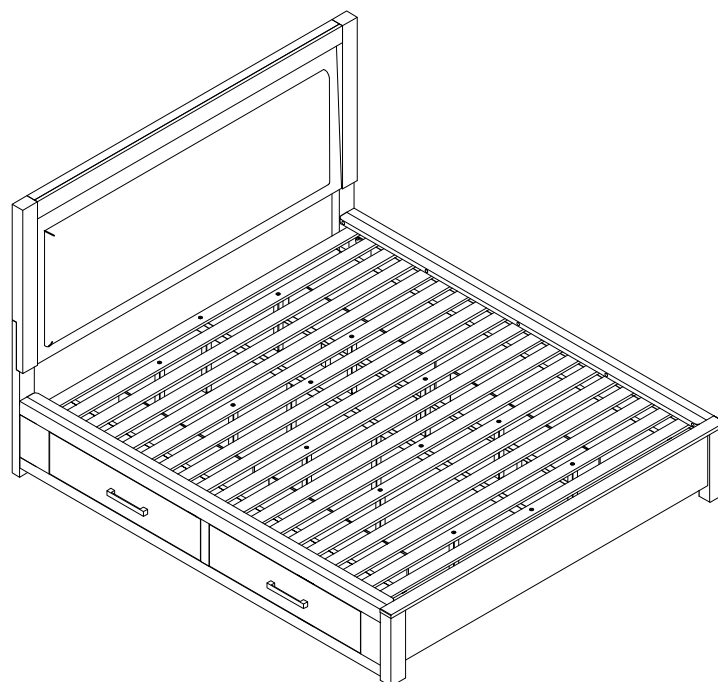

# ITEM: 224850KW(B1-B3)



Inner Size : 73.00"W X 86.00"D

Inner Size of Drawer : 33.00"W X 17.50"D X 7.00"H X 0.50"T

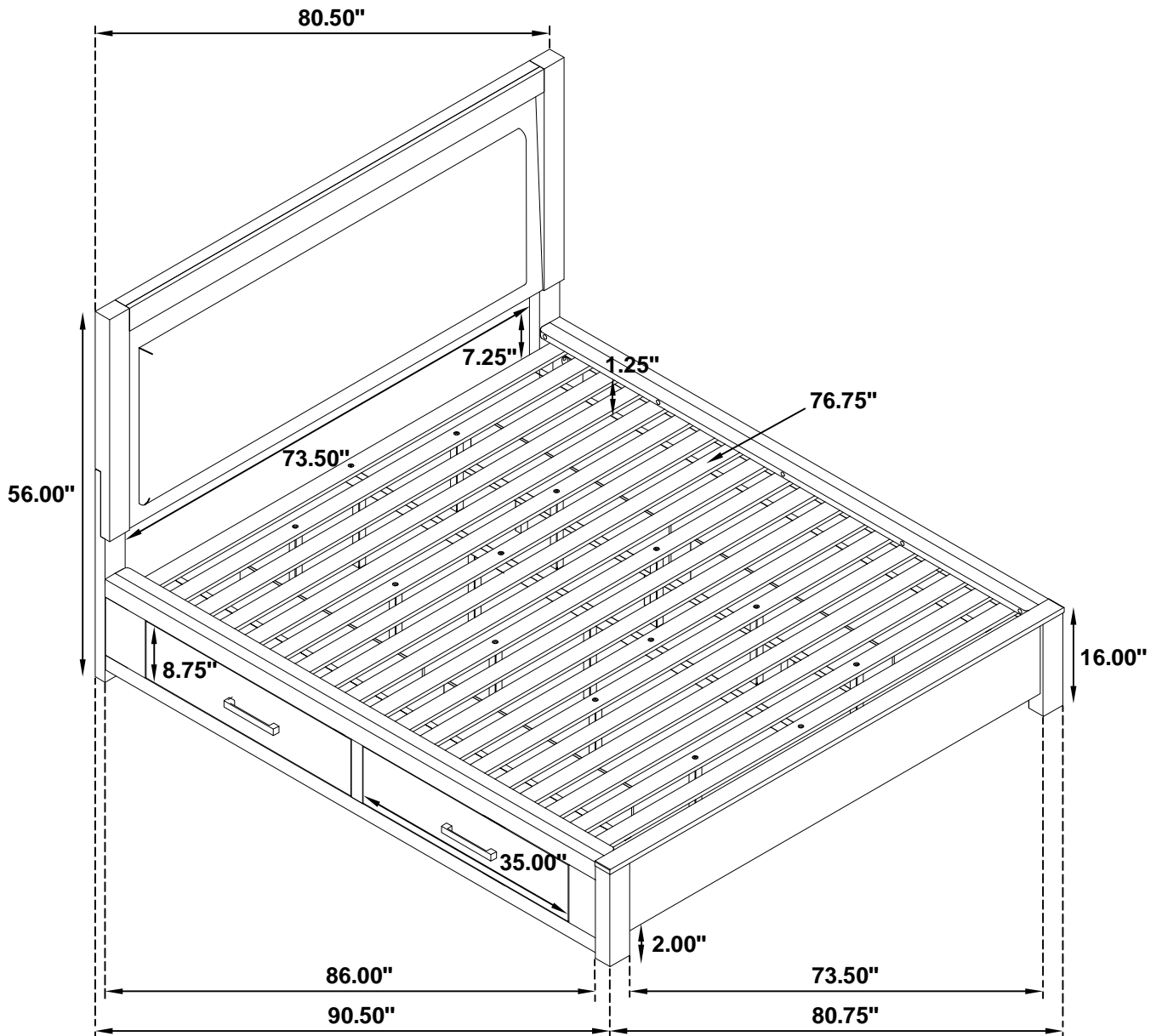

Note: Dimension tolerance  $\pm 5\%$