

ASSEMBLY INSTRUCTIONS
COASTER FINE FURNITURE



Fine Furniture for every stage of life

108501
DINING TABLE

ITEM:108501



ASSEMBLY INSTRUCTIONS

ASSEMBLY TIPS:

1. Remove hardware from box and sort by size.
2. Please check to see that all hardware and parts are present prior to start of assembly.
3. Please follow attached instructions in the same sequence as numbered to assure fast & easy assembly.



WARNING!

1. Don't attempt to repair or modify parts that are broken or defective. Please contact the store immediately.
2. This product is for home use only and not intended for commercial establishments.



ASSEMBLY TIME 45 MINUTES

PARTS IDENTIFICATION

B1: TOP

A GLASS

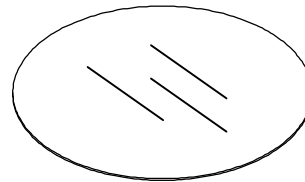

1PC

B2: BASE

B CROSSBAR

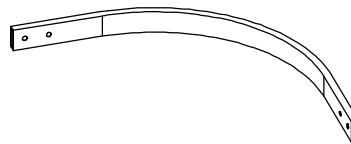

8PCS

C LEG

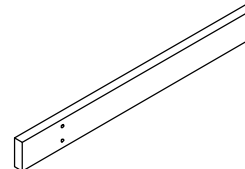

4PCS

Z

HARDWARE IDENTIFICATION

1 SHORT BOLT
(1/4" x 45mm SR) 16PCS



5 SUCTION CUP 4PCS



2 NUT
(1/4" x 15mm SR) 16PCS



6 COVER 16PCS



3 WASHER
(1/4" SR) 16PCS



7 ALLEN WRENCH
(4mm) 2PCS



4 CAP
(13 x 38mm SR) 16PCS

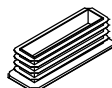

HARDWARE PACK IS LOCATED IN 108501 (B2)

ITEM:108501



ASSEMBLY INSTRUCTIONS

STEP 1 Do not tighten until each step is completed or instructed.

Repeat 8 times

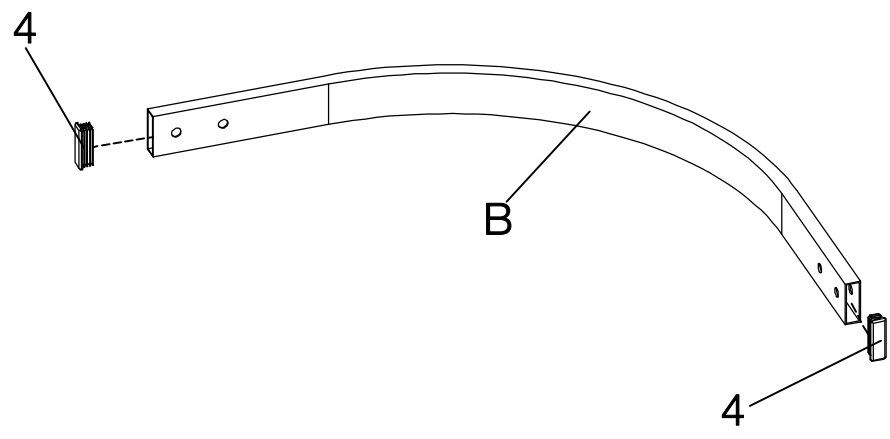

STEP 2

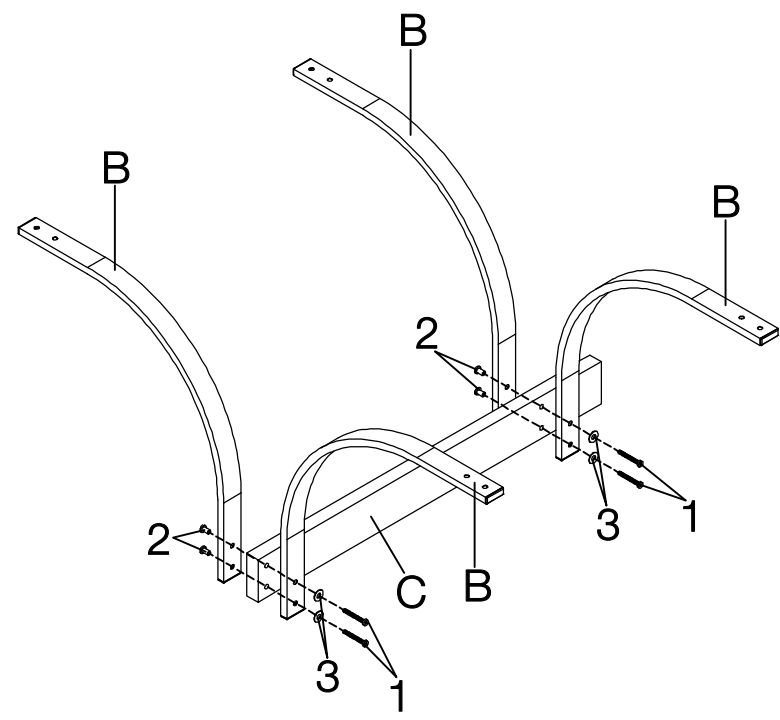

ITEM:108501

ASSEMBLY INSTRUCTIONS

STEP 3

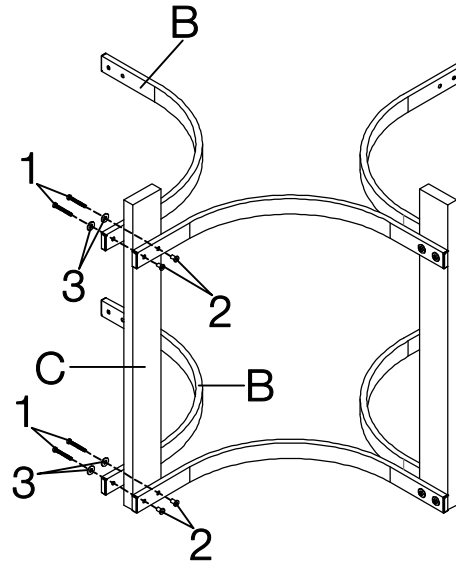

STEP 4

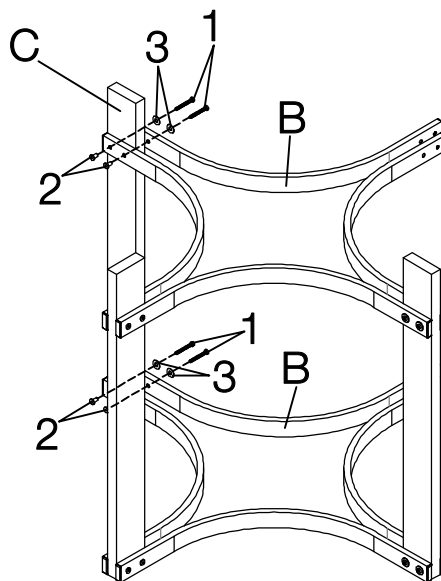

ITEM:108501

ASSEMBLY INSTRUCTIONS

STEP 5

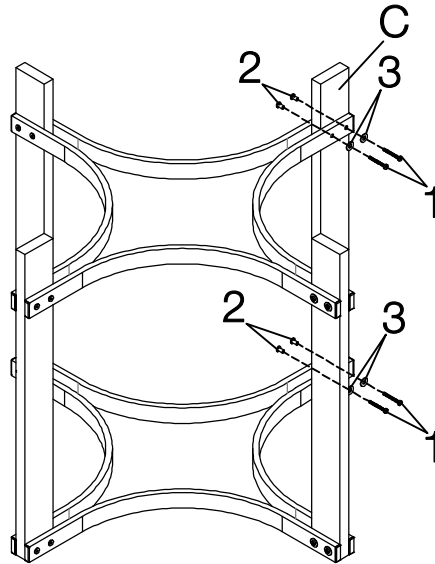

STEP 6

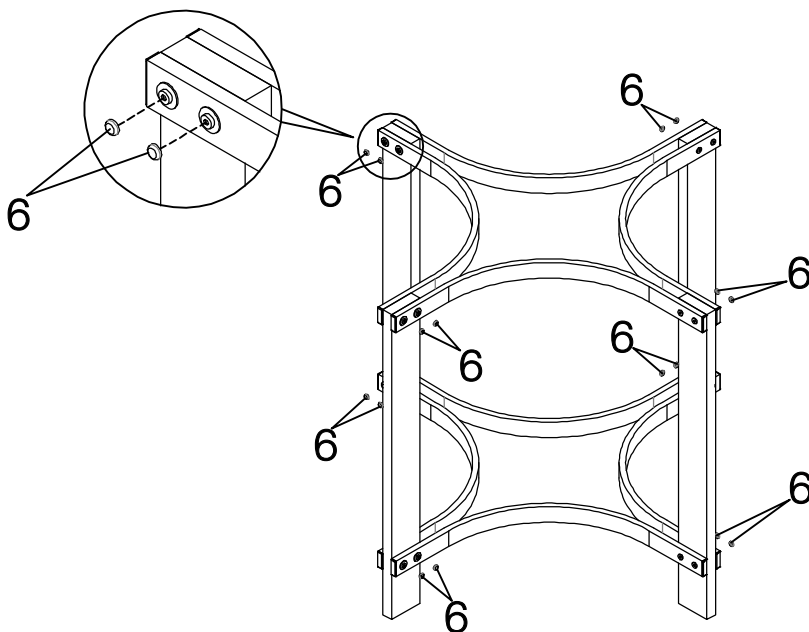

ITEM:108501

ASSEMBLY INSTRUCTIONS

STEP 7

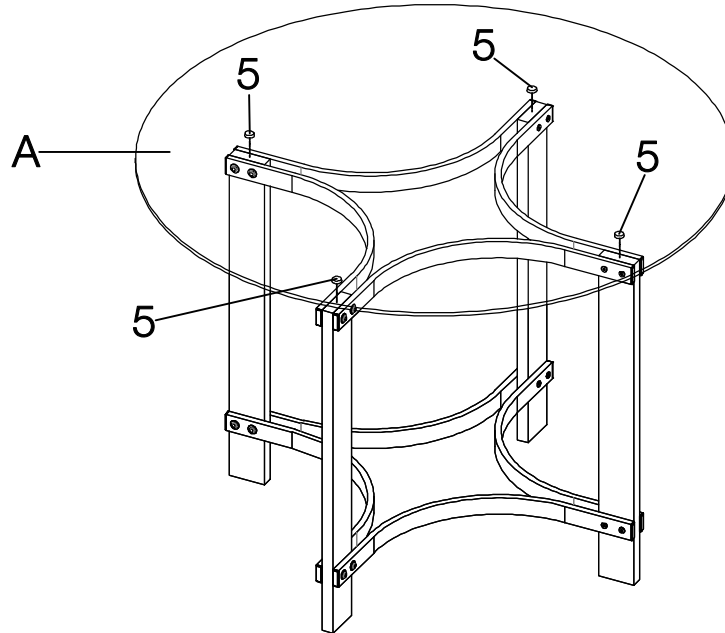

STEP 8
COMPLETE

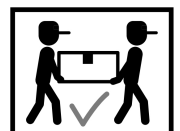
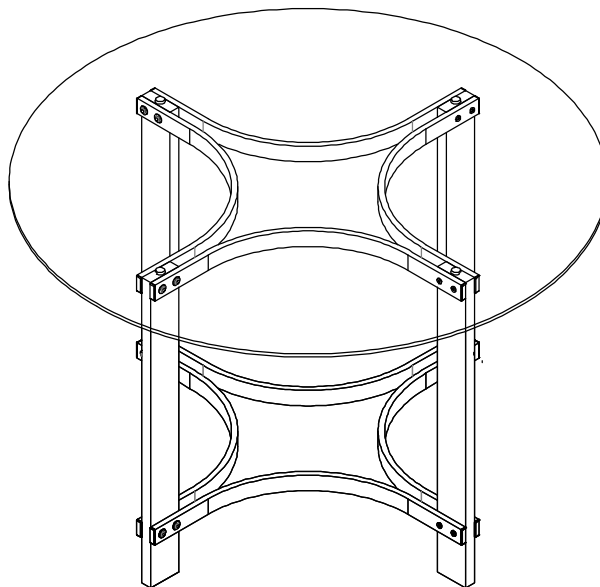

ITEM:108501 ASSEMBLY INSTRUCTIONS



Product Size : 1200 DIA X 762 H (MM)
Product Size : 47.25" DIA X 30"

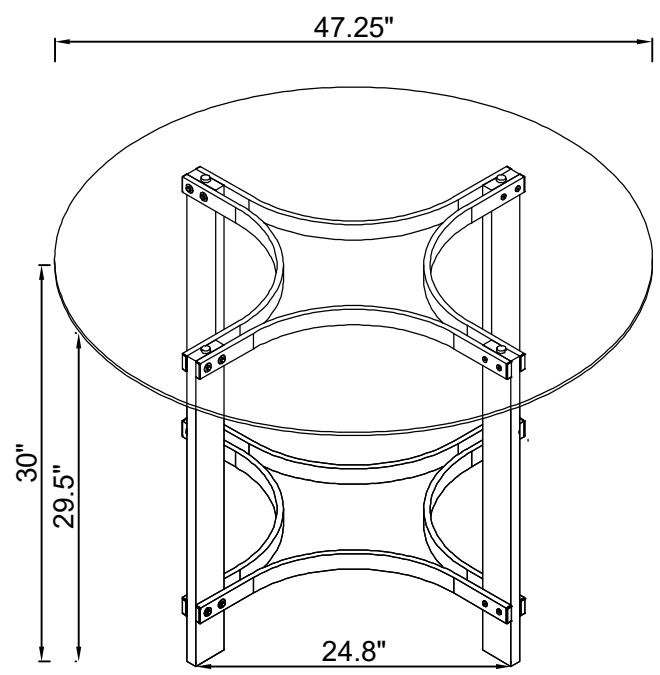

Note : Dimension tolerance $\pm 5\%$