

**ASSEMBLY INSTRUCTIONS**  
**COASTER FINE FURNITURE**



*Fine Furniture for every stage of life*

**953478**  
**ACCENT CABINET**

ITEM:953478

## ASSEMBLY INSTRUCTIONS

### ASSEMBLY TIPS:

1. Remove hardware from box and sort by size.
2. Please check to see that all hardware and parts are present prior to start of assembly.
3. Please follow attached instructions in the same sequence as numbered to assure fast & easy assembly.



### WARNING!

1. Don't attempt to repair or modify parts that are broken or defective. Please contact the store immediately.
2. This product is for home use only and not intended for commercial establishments.

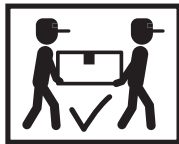

ASSEMBLY TIME

60 MINUTES

## PARTS IDENTIFICATION

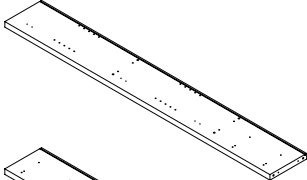
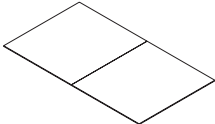
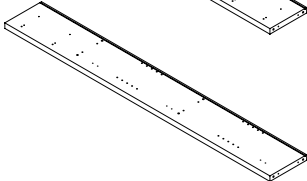
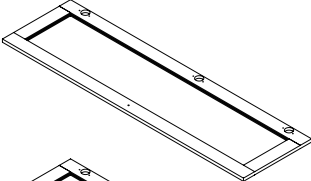
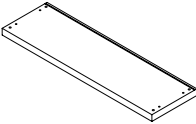
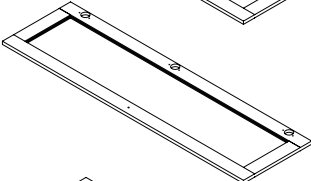
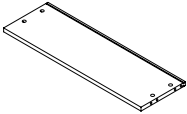
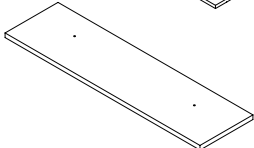
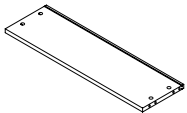
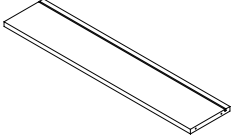
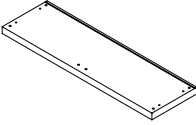
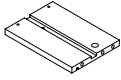
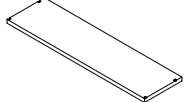
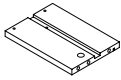
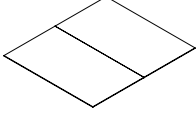
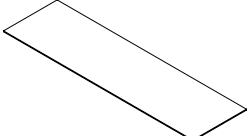









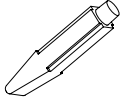

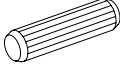

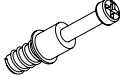
A	LEFT SIDE PANEL		1 PC	I	LOWER BACK PANEL		1 PC
B	RIGHT SIDE PANEL		1 PC	J	LEFT DOOR		1 PC
C	BOTTOM PANEL		1 PC	K	RIGHT DOOR		1 PC
D	LOWER CROSS PANEL		1 PC	L	DRAWER FRONT PANEL		1 PC
E	UPPER CROSS PANEL		1 PC	M	DRAWER BACK PANEL		1 PC
F	TOP PANEL		1PC	N	LEFT DRAWER SIDE PANEL		1 PC
G	ADJUSTABLE SHELF		2 PCS	O	RIGHT DRAWER SIDE PANEL		1 PC
H	UPPER BACK PANEL		2 PCS	P	DRAWER BOTTOM PANEL		1 PC

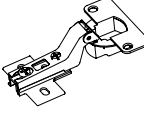
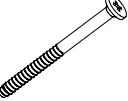
### NOTE:

Phillips head screw driver is required in the assembly process; however, manufacturer does not provide this item.

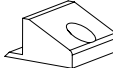
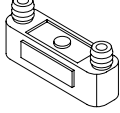
ITEM:953478

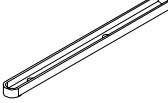
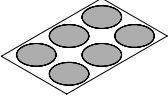
## HARDWARE IDENTIFICATION

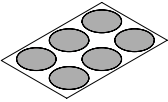
Z							
NO	DESCRIPTION	FIGURE	Q'TY	NO	DESCRIPTION	FIGURE	Q'TY
1	GLUE 15g		1 PC	11	PLASTIC RIVET		4 PCS
2	WOODEN DOWEL Ø8 x 30mm		24 PCS	12	KNOB		6 PCS
3	CAM BOLT Ø7 x 35.5mm SR		12 PCS	13	HANDLE BOLT BLK		6 PCS
4	CAM LOCK Ø15 x 12mm SR		12 PCS	14	HINGE Ø35mm SR		6 PCS
5	BOLT Ø9.5 x 55mm SR		8 PCS	15	HINGE SCREW Ø4 x 15mm SR		24 PCS
6	SCREW Ø4.3 x 35mm SR		8 PCS	16	FOOT Ø35 x H19mm		4 PCS
7	PIN FOR ADJUSTABLE SHELF Ø4.9 x 15mm SR		8 PCS	17	BACK PANEL SUPPORT		6 PCS
8	DOOR CATCH		2 PCS	18	BACK PANEL SUPPORT SCREW Ø3 x 19mm SR		6 PCS
9	GLIDES L = 200mm		4 PCS	19	STICKER-BLK Ø20mm		2 PCS
10	HANDLE BOLT SR		8 PCS	20	STICKER Ø20mm		1 PC

Z9, Z10, Z11, Z12, Z14, Z16 not included in blister packaging.

**NOTE:**

Phillips head screw driver is required in the assembly process; however, manufacturer does not provide this item.

ITEM: 953478

**COASTER**  
FINE FURNITURE

**STEP 1**

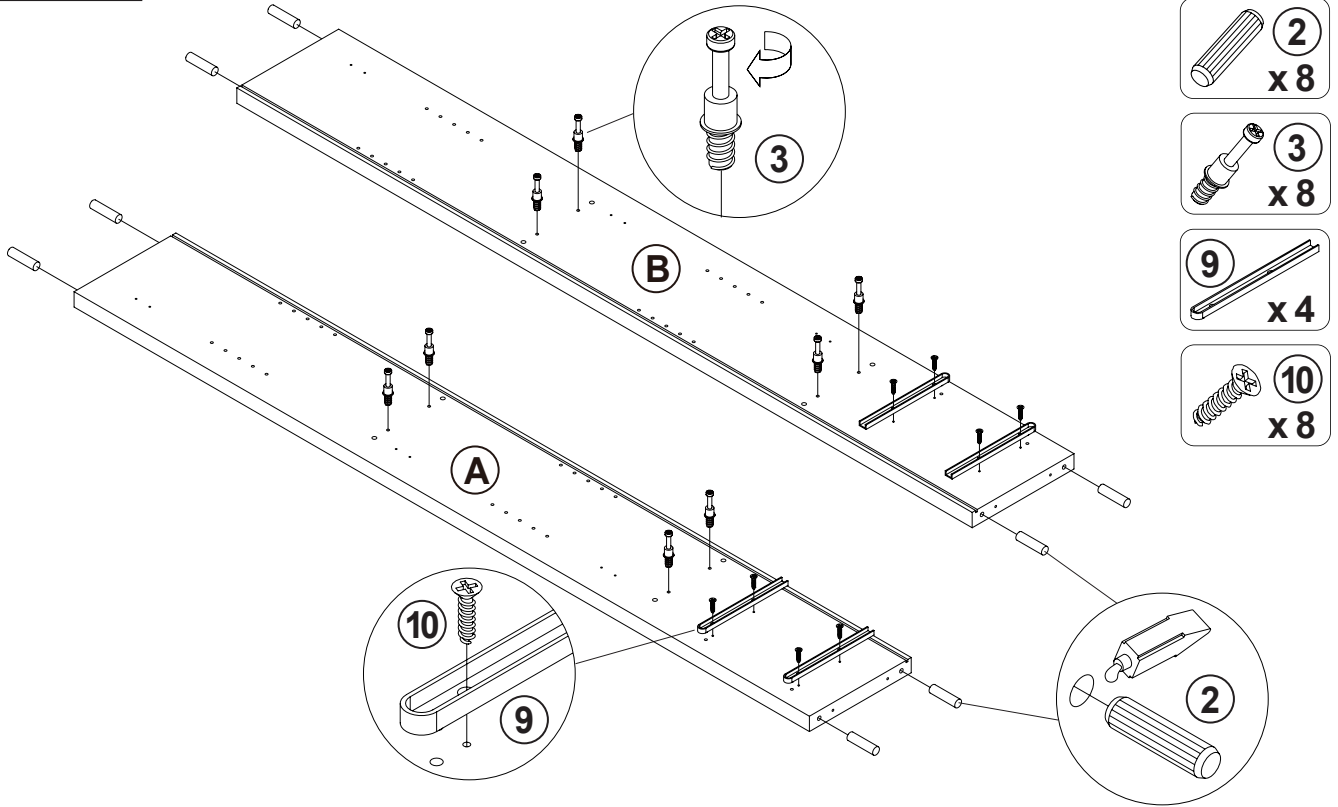

**STEP 2**

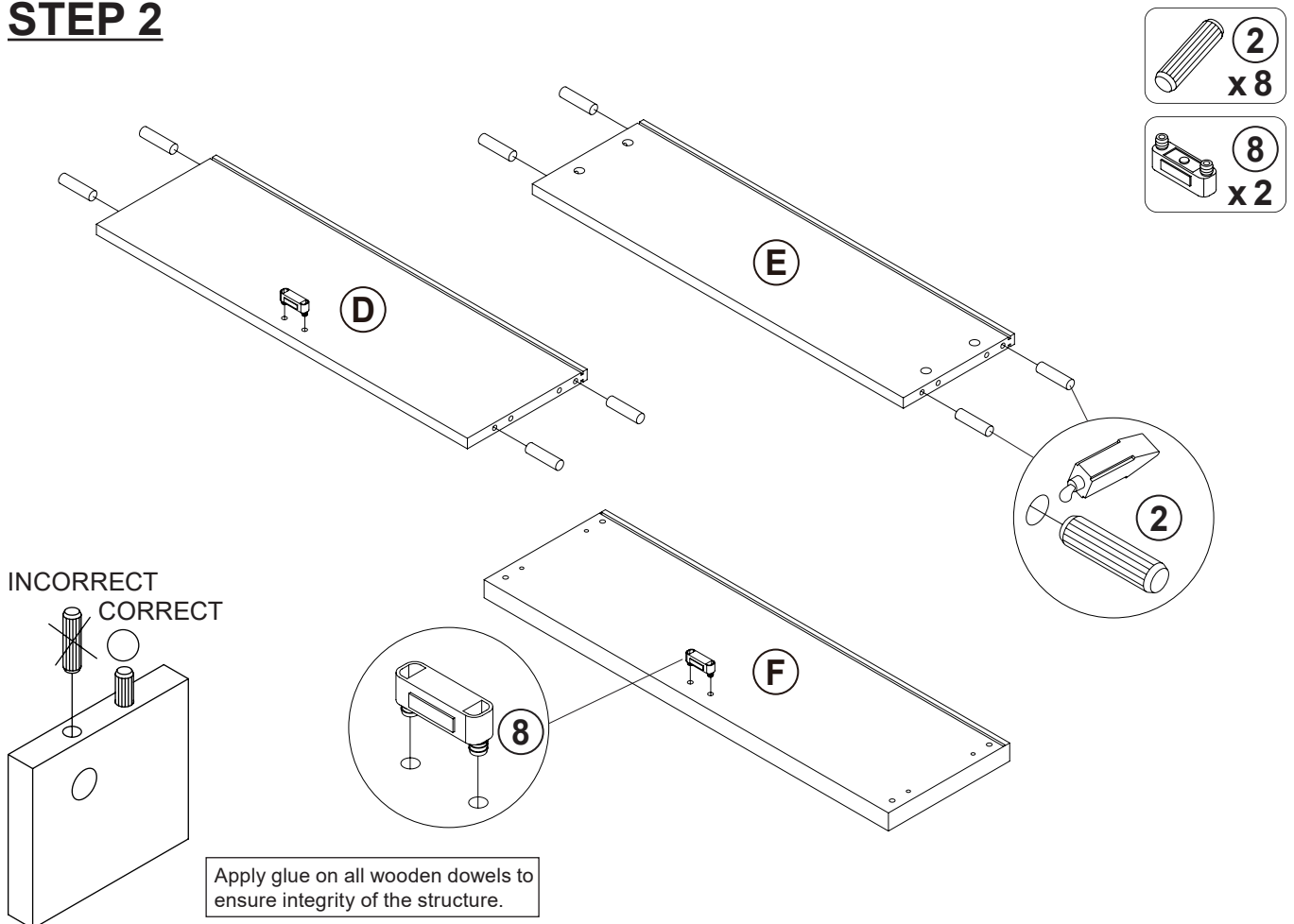

ITEM: **953478**

**COASTER**<sup>®</sup>

FINE FURNITURE

**STEP 3**

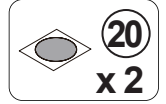
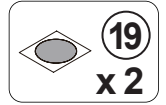
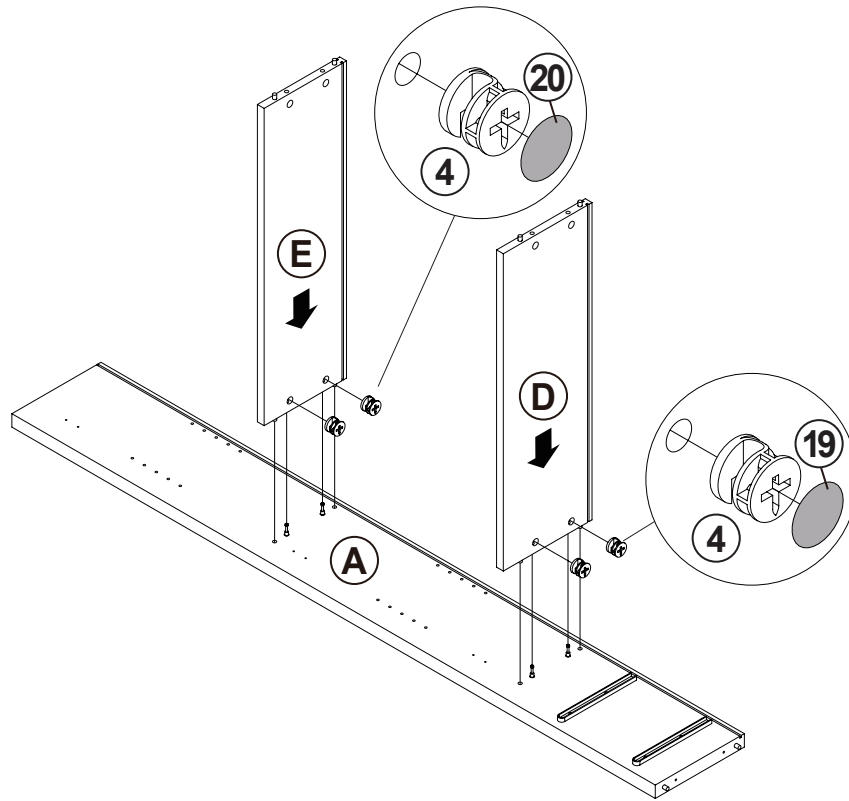
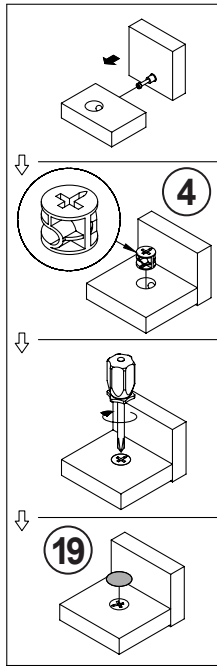

**STEP 4**

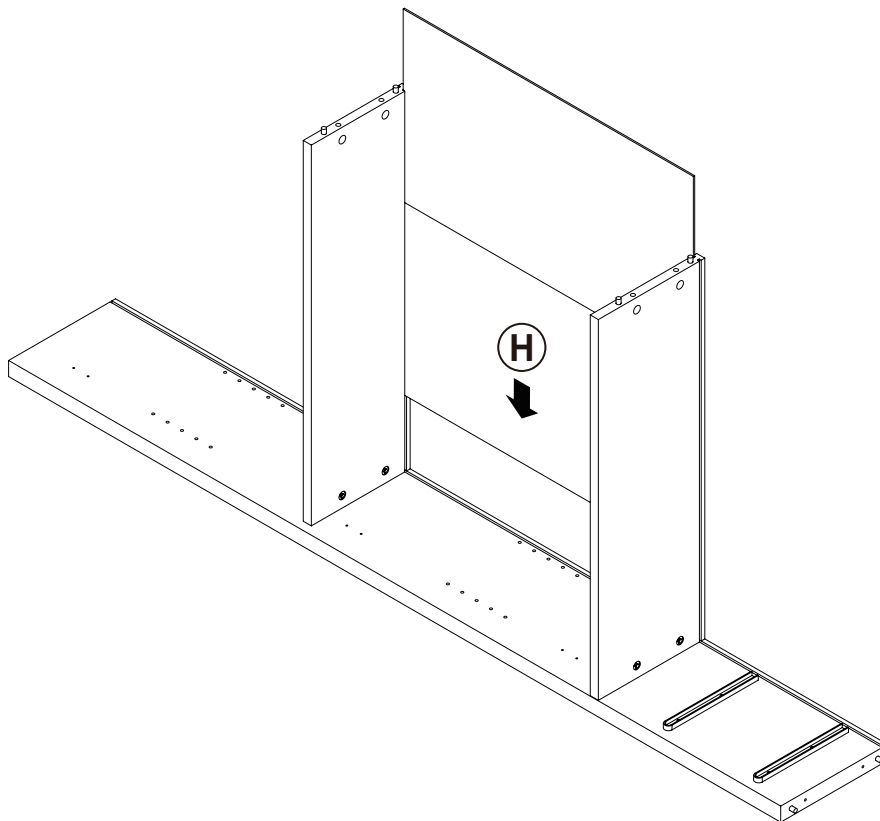

ITEM: **953478**

**COASTER**<sup>®</sup>

FINE FURNITURE

**STEP 5**

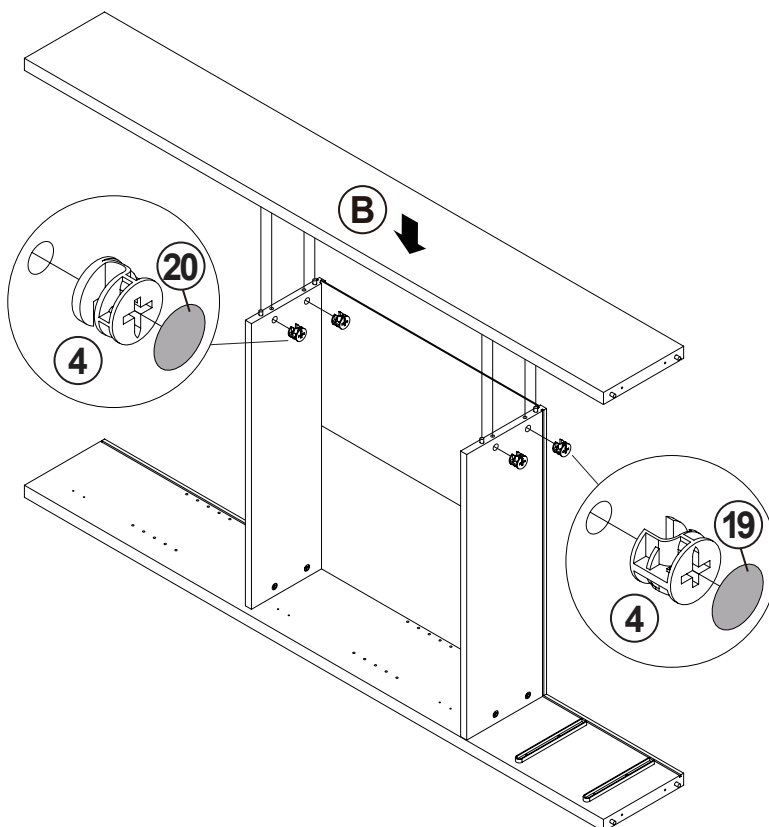
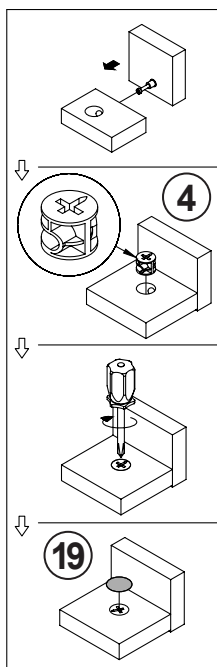
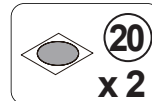
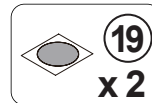

**STEP 6**

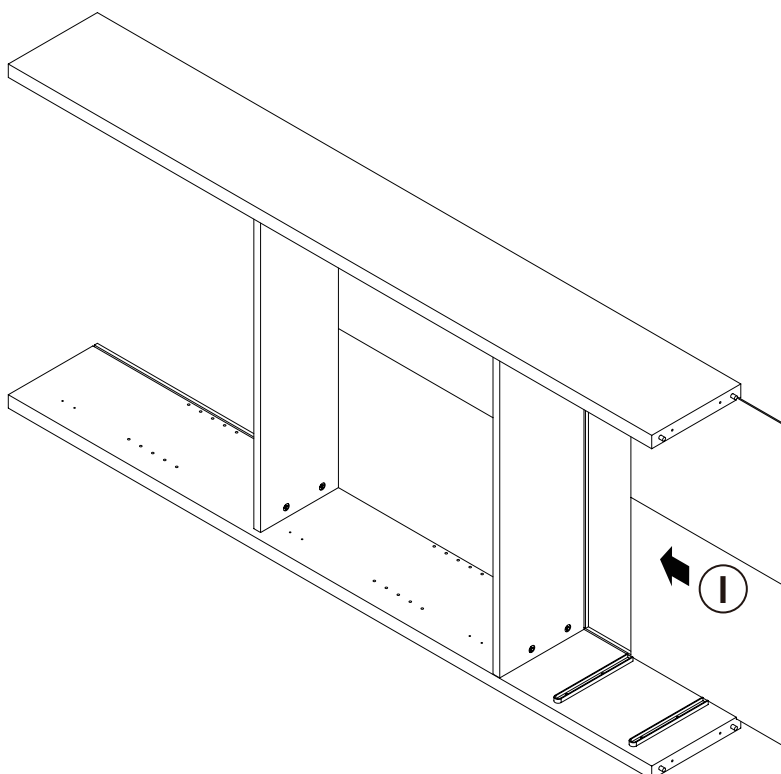

ITEM: 953478

**COASTER**  
FINE FURNITURE

**STEP 7**

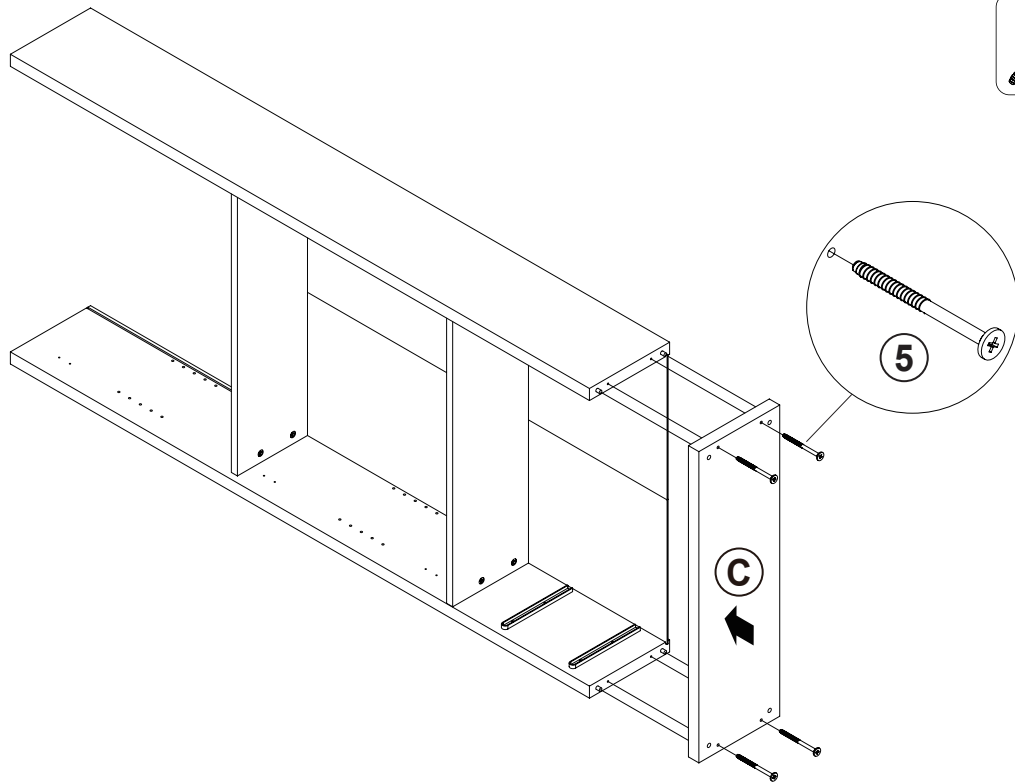
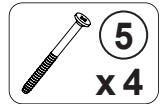

**STEP 8**

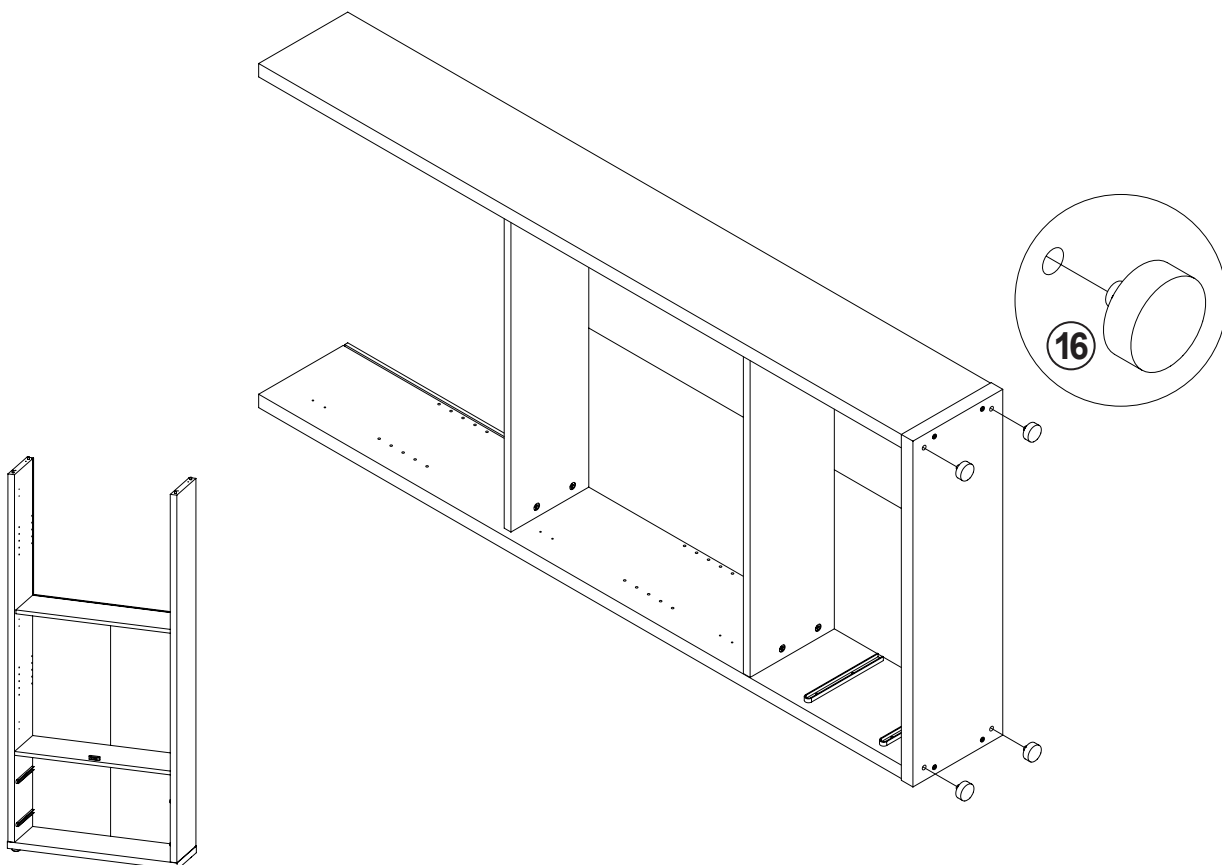
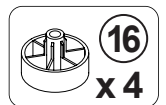

ITEM: **953478**

**STEP 9**

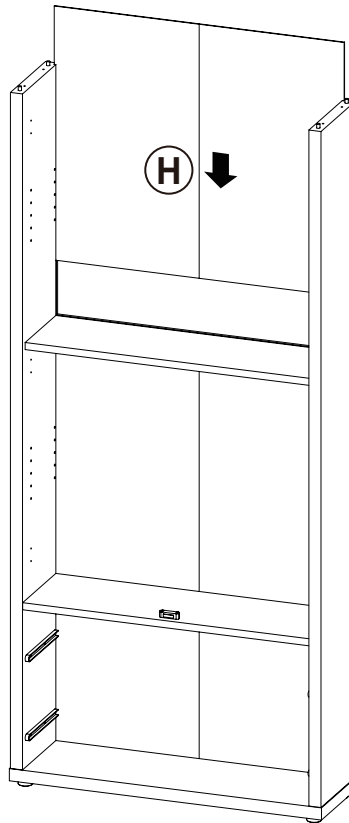

**STEP 10**

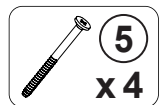
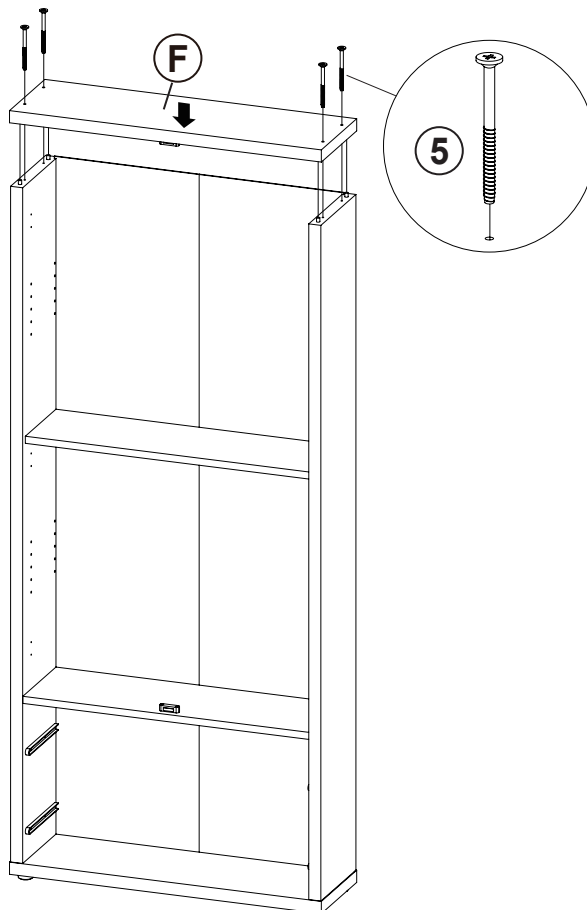



ITEM: 953478

**COASTER**  
FINE FURNITURE

**STEP 11**

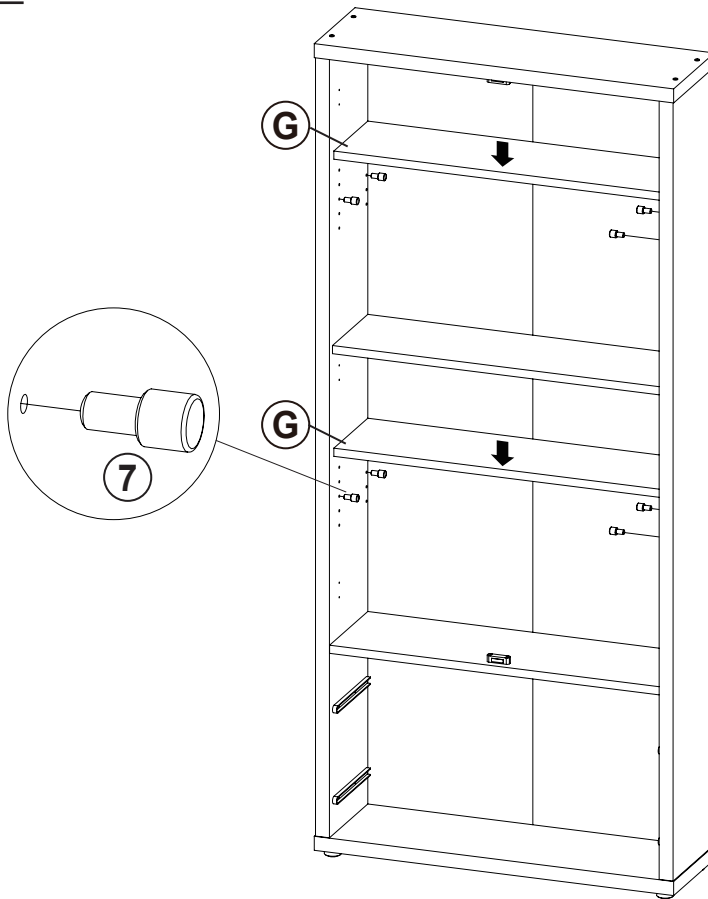
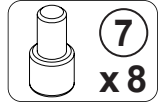

**STEP 12**

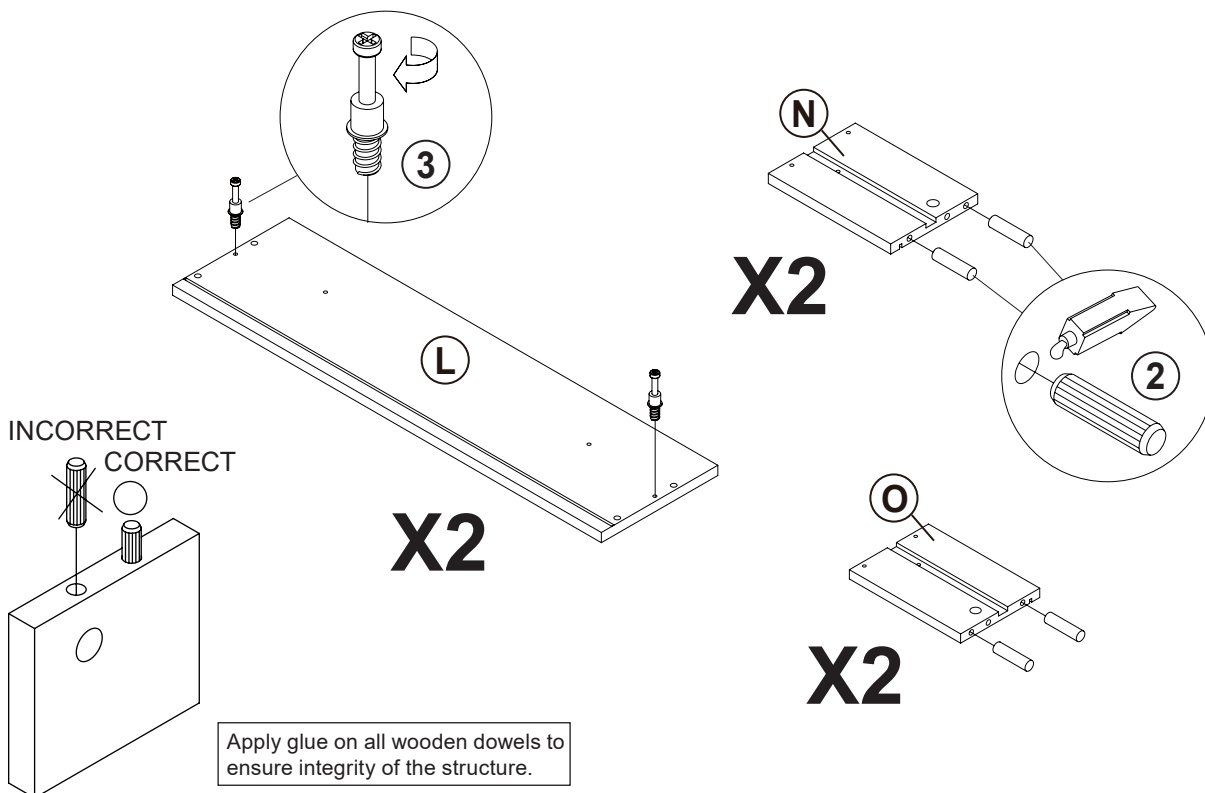
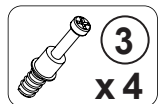
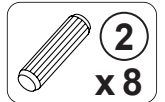

ITEM: 953478

**STEP 13**

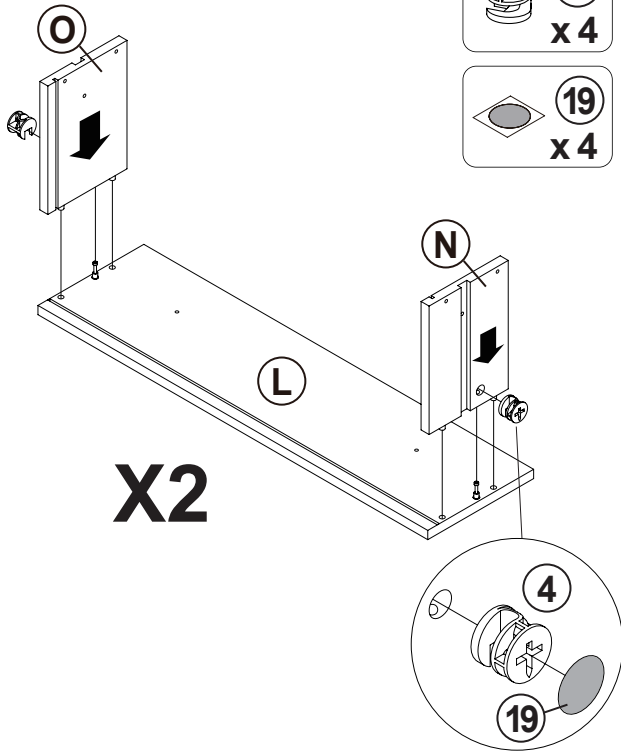

**STEP 14**

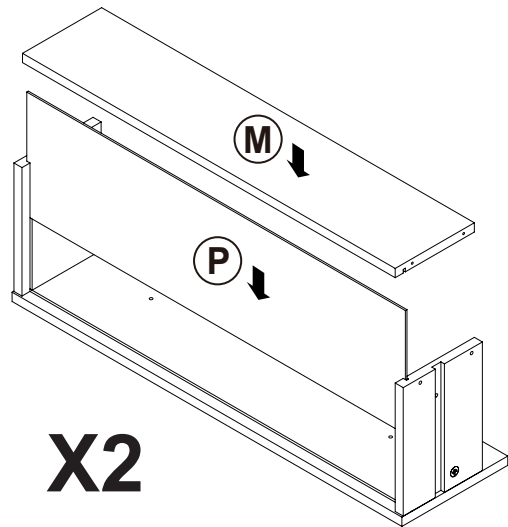

**STEP 15**

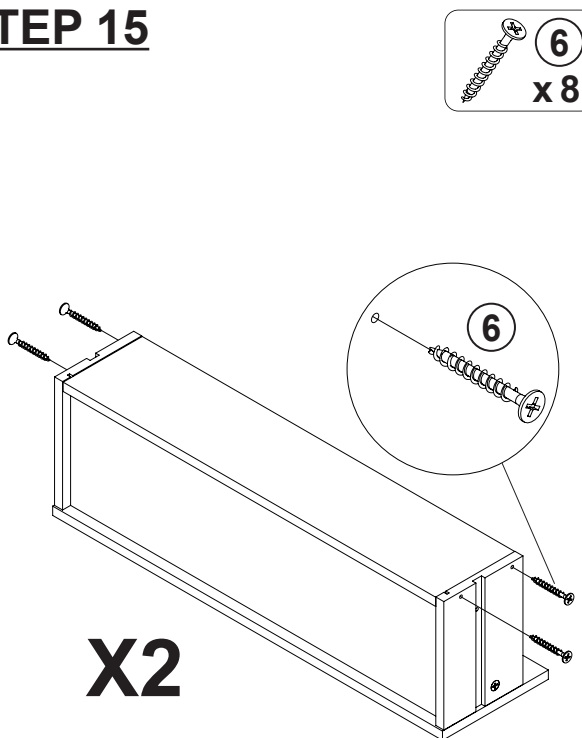

**STEP 16**

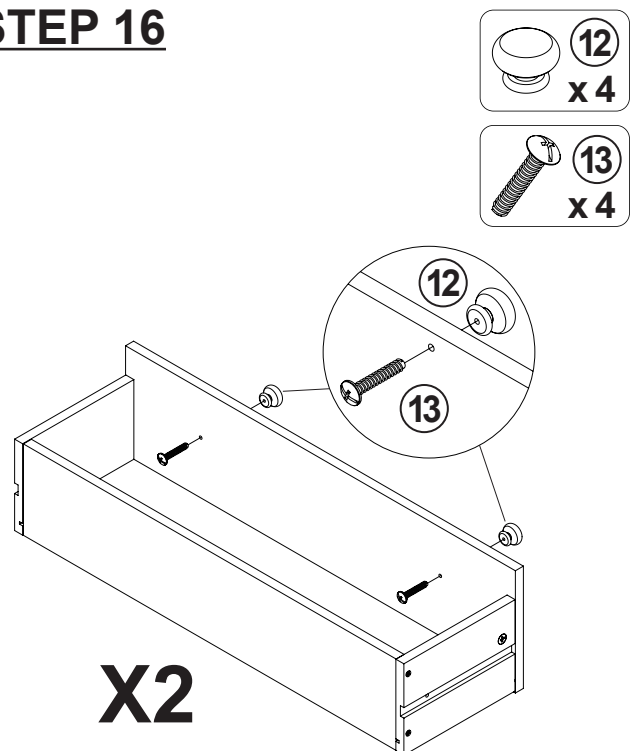

ITEM: 953478

**STEP 17**

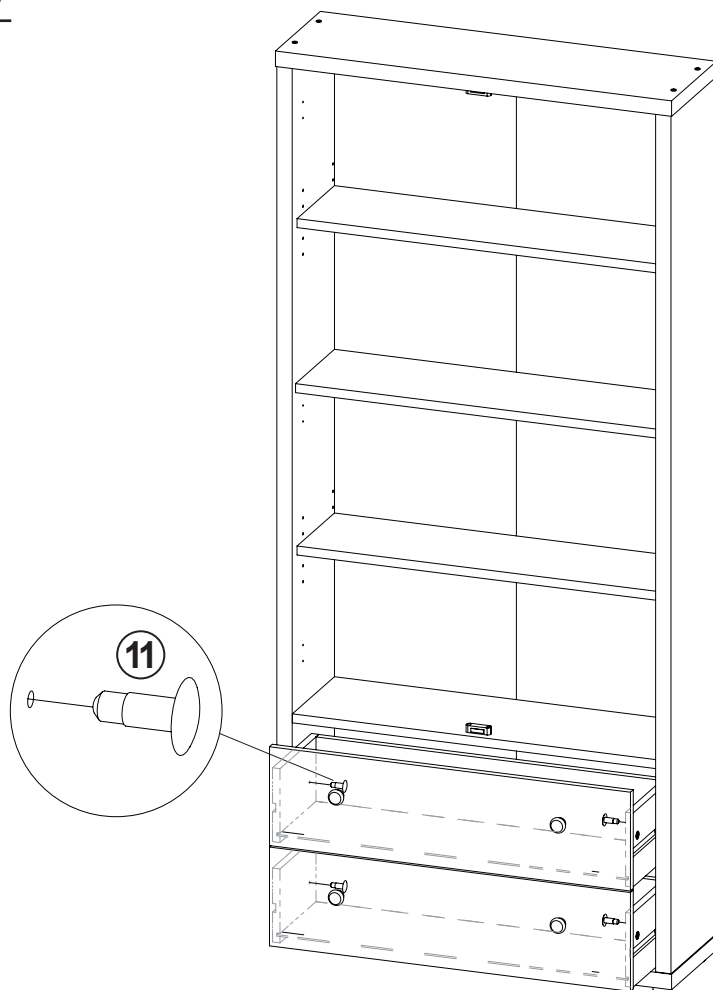
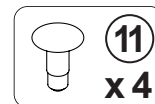

**STEP 18**

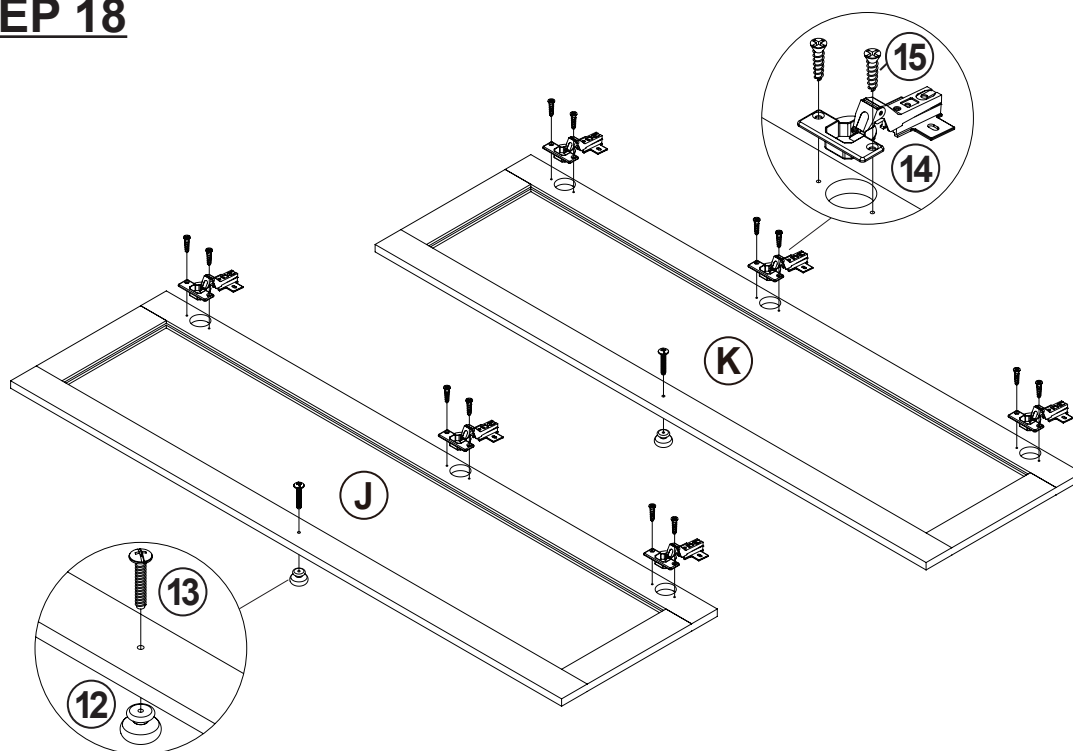
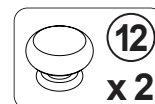

ITEM: 953478

**STEP 19**

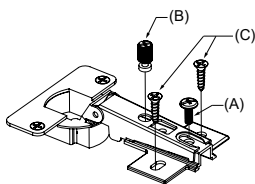
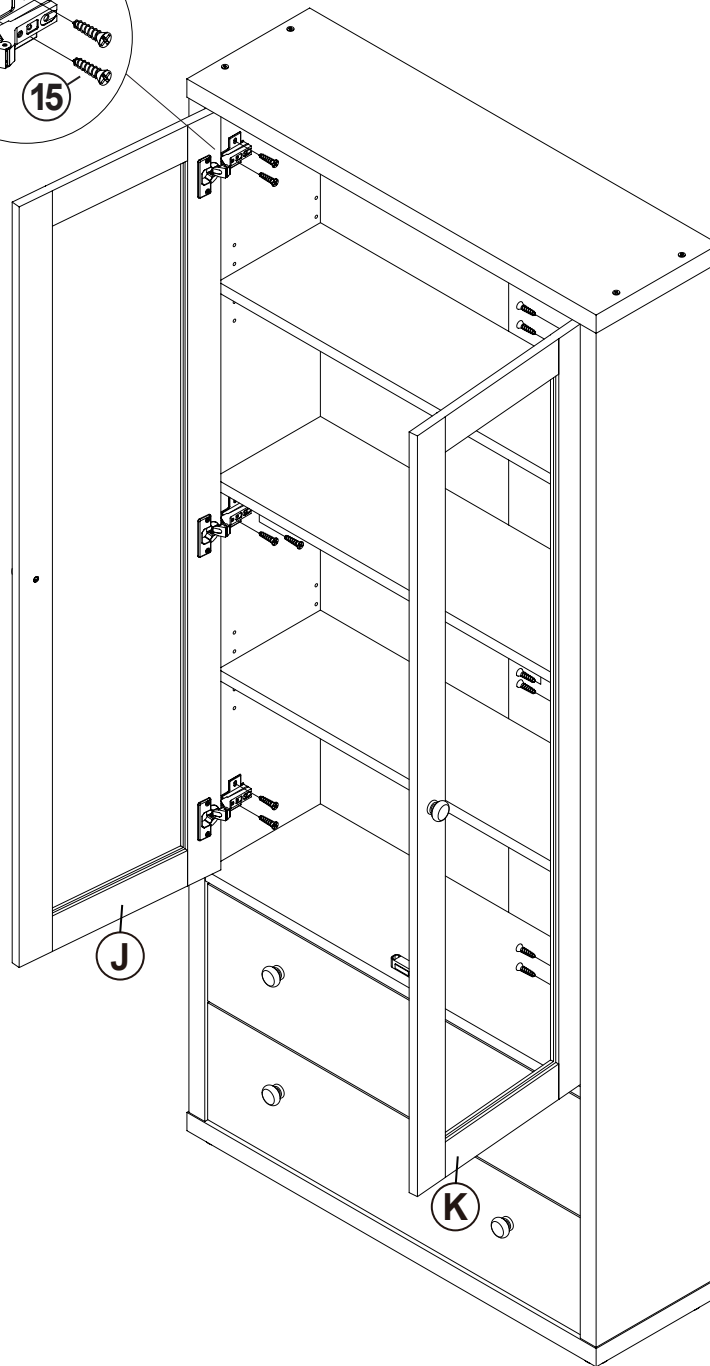
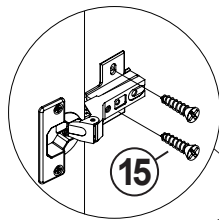
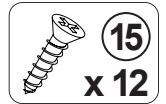

HORIZONTAL BY  
SCREW A ADJUSTMENT

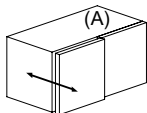

LATERAL BY  
SCREW B ADJUSTMENT

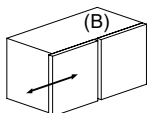

VERTICAL BY  
SCREW C ADJUSTMENT

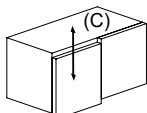

ITEM: **953478**

**STEP 20**

**COASTER**  
FINE FURNITURE

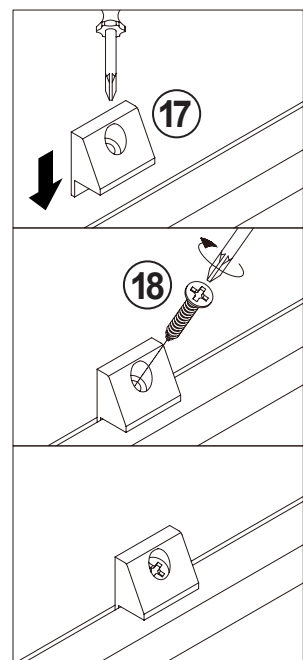
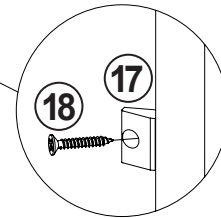
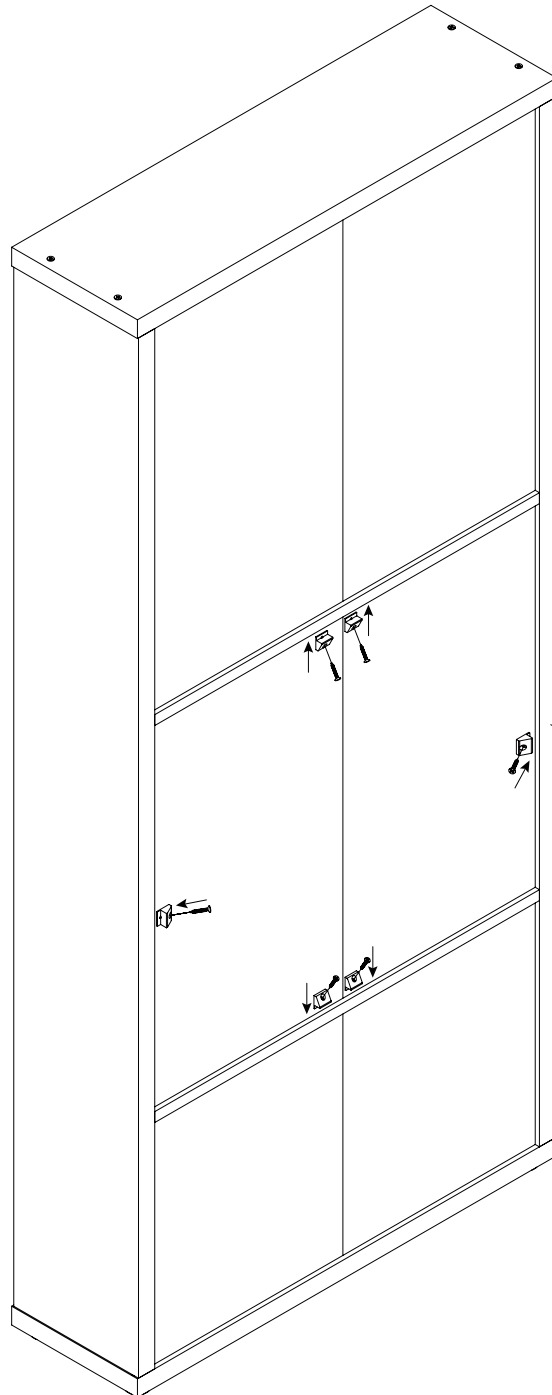
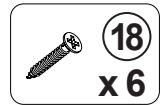

ITEM: **953478**

**STEP 21**

**COMPLETE**

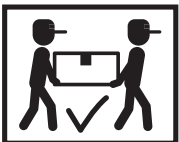
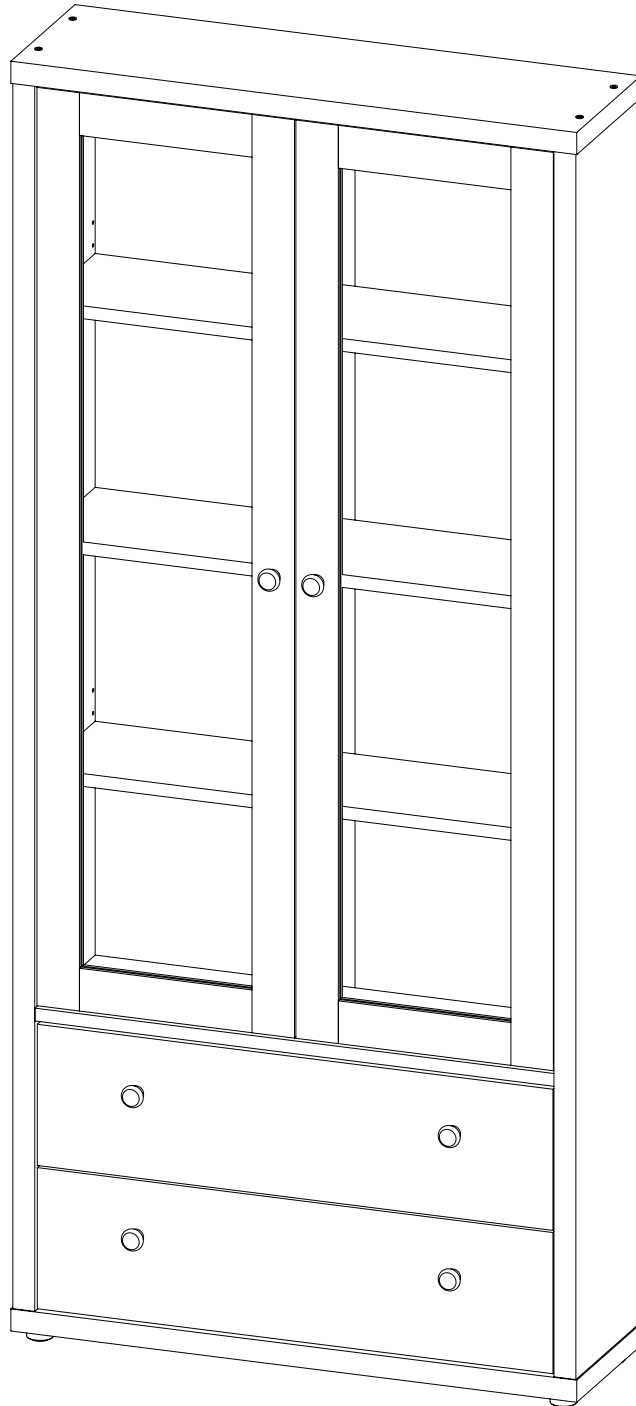

ITEM:953478

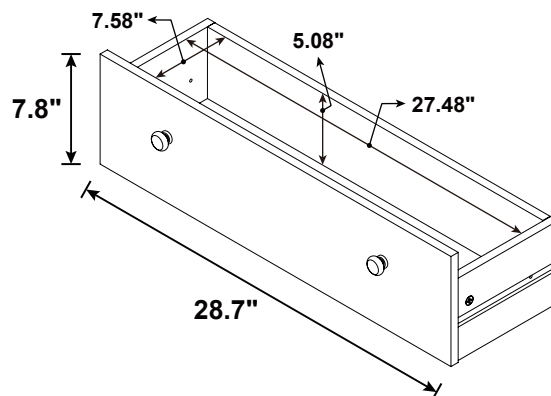
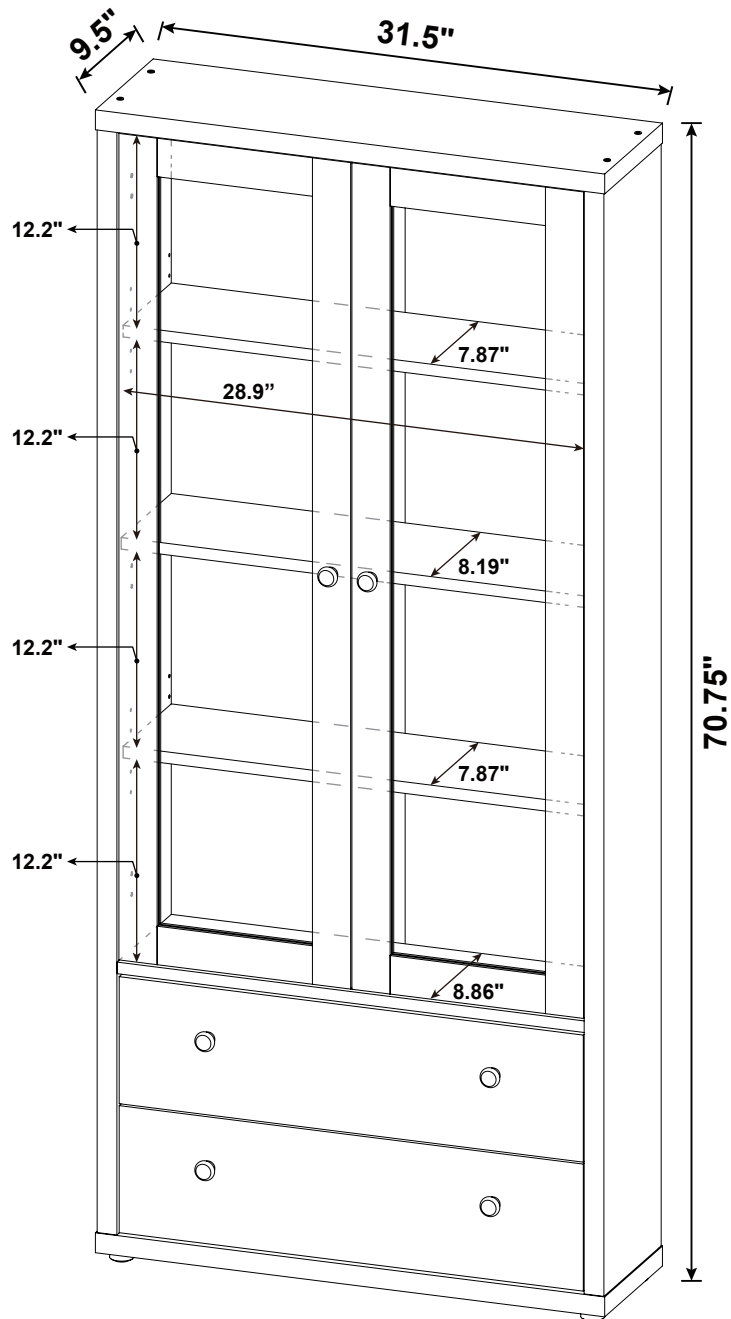

Note : Dimension tolerance  $\pm 5\%$

## ANTI-TIPPING INSTALLMENT INSTRUCTIONS FURNITURE TIPPING RESTRAINT

### WARNING

Injury may result from tipping furniture.  
 This restraint may protect against tipping furniture.  
 Do not allow children to climb on furniture.  
 This restraint is not a substitute for proper adult supervision.  
 Failure to detach this restraint before moving the furniture may result in injury and damage.

This restraint must be screwed to a wood stud on the wall, using the long screw provided.

### STEP 1

Secure the bracket to the back top of the unit, using the short screw provided, as shown in the drawing.

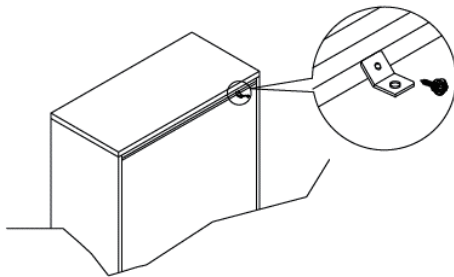

### STEP 2

Locate the wood stud on the wall, and secure the other bracket, 2 inches below the back of the unit.

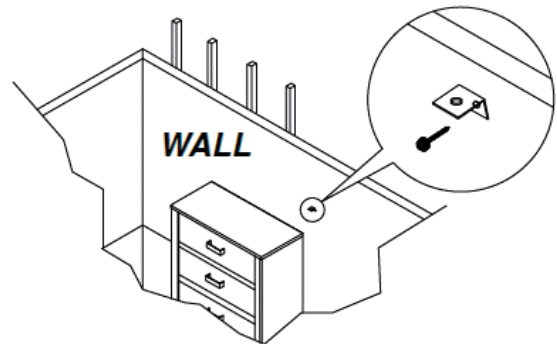

### STEP 3

Place the furniture into position so both mounting brackets are vertically in line. Lace the end of the restraint strap through the larger hole in each mounting bracket. Bring both ends together and slide the flat end through the locking end, and drag it through, until the slack is removed. Ensure that the strap is securely laced and locked.

