



ASSEMBLY INSTRUCTIONS COASTER FINE FURNITURE



Fine Furniture for every stage of life

306051Q
Queen Bed

ITEM: 306051Q



ASSEMBLY INSTRUCTIONS

ASSEMBLY TIPS:

1. Remove hardware from box and sort by size.
2. Please check to see that all hardware and parts are present prior to start of assembly.
3. Please follow attached instructions in the same sequence as numbered to assure fast & easy assembly.



WARNING!

1. Don't attempt to repair or modify parts that are broken or defective. Please contact the store immediately.
2. This product is for home use only and not intended for commercial establishments.



ASSEMBLY TIME

15 MINUTES

PARTS IDENTIFICATION

A	HEADBOARD PANEL		1PC	E	BED RAIL		2PCS
B	LEFT HEADBOARD LEG		1PC	F	BED SLAT		4PCS
C	RIGHT HEABOARD LEG		1PC	G	BED SLAT SUPPORT WITH LEVELER		4PCS
D	FOOTBOARD PANEL		1PC	H	FOOTBOARD LEG		2PCS

HARDWARE IDENTIFICATION

1	BOLT (Ø5/16" x 50mm - BLK)		4PCS	6	CURVE WASHER (Ø5/16" - BLK)		8PCS
2	THREADED BOLT (Ø5/16" x 90mm - BLK)		14PCS	7	HEX NUT (Ø5/16" - BLK)		14PCS
3	LOCK WASHER (Ø5/16" - BLK)		10PCS	8	WRENCH (14mm - BLK)		1PC
4	FLAT WASHER (Ø5/16" - BLK)		10PCS	9	FLAT HEAD SCREW (M4 x 30mm - BLK)		8PCS
5	ALLEN WRENCH (M5 x 75mm - BLK)		1PC				

NOTE:

Phillips head screw driver is required in the assembly process; however, manufacturer does not provide this item.

ITEM: **306051Q**

ASSEMBLY INSTRUCTIONS



STEP 1

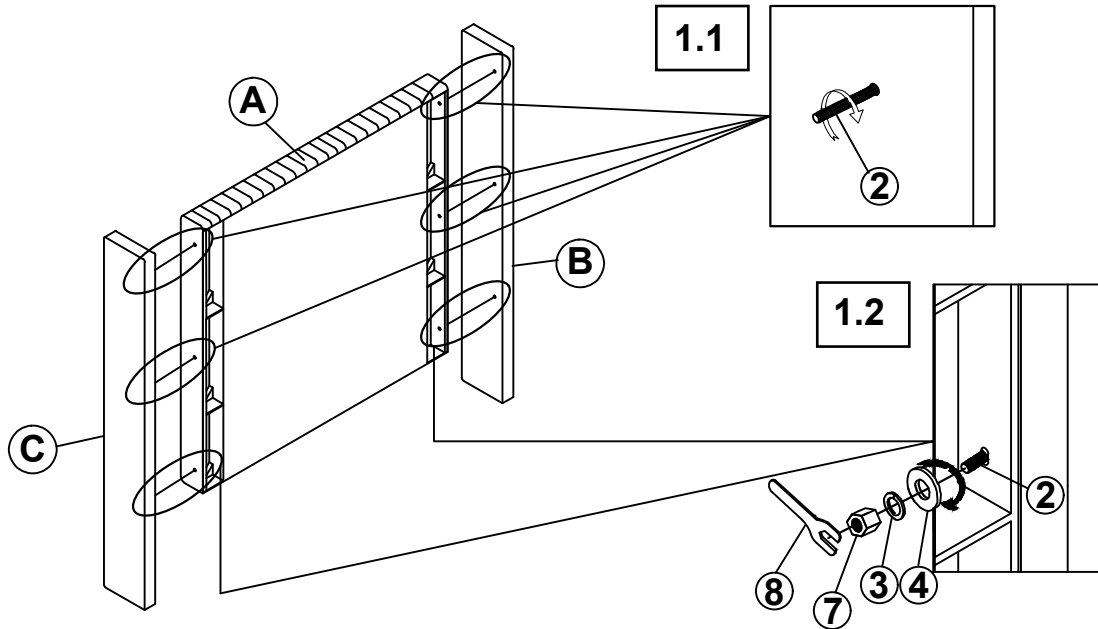

BACK VIEW

STEP 2

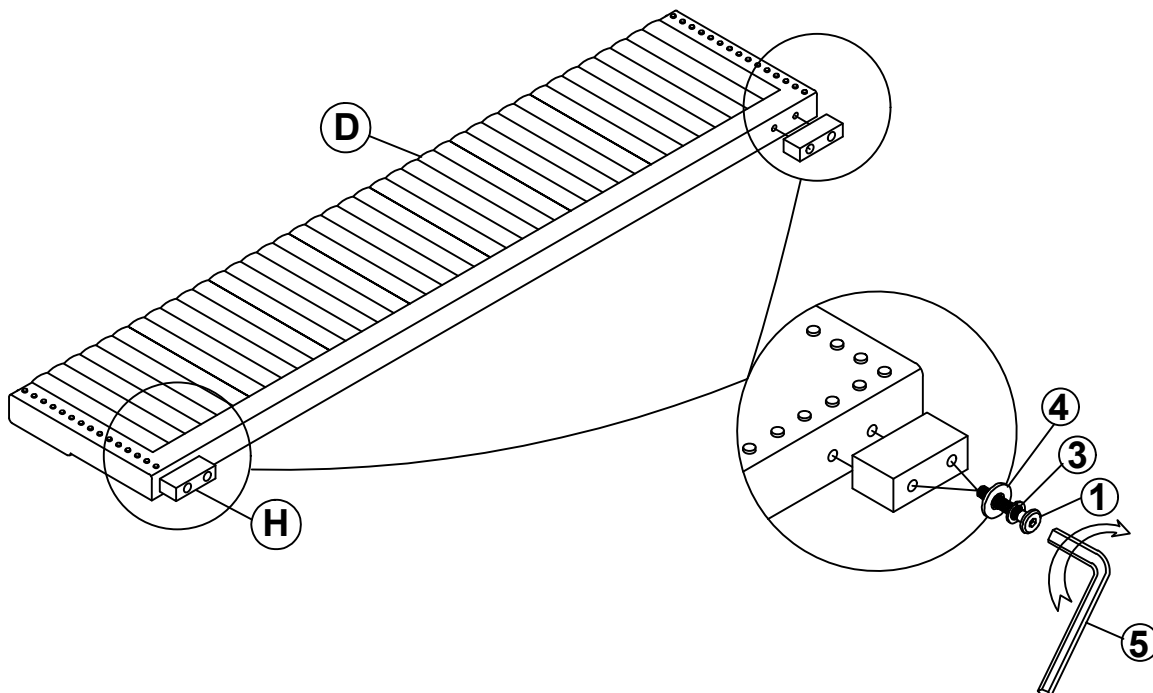

ITEM: **306051Q**

ASSEMBLY INSTRUCTIONS



STEP 3

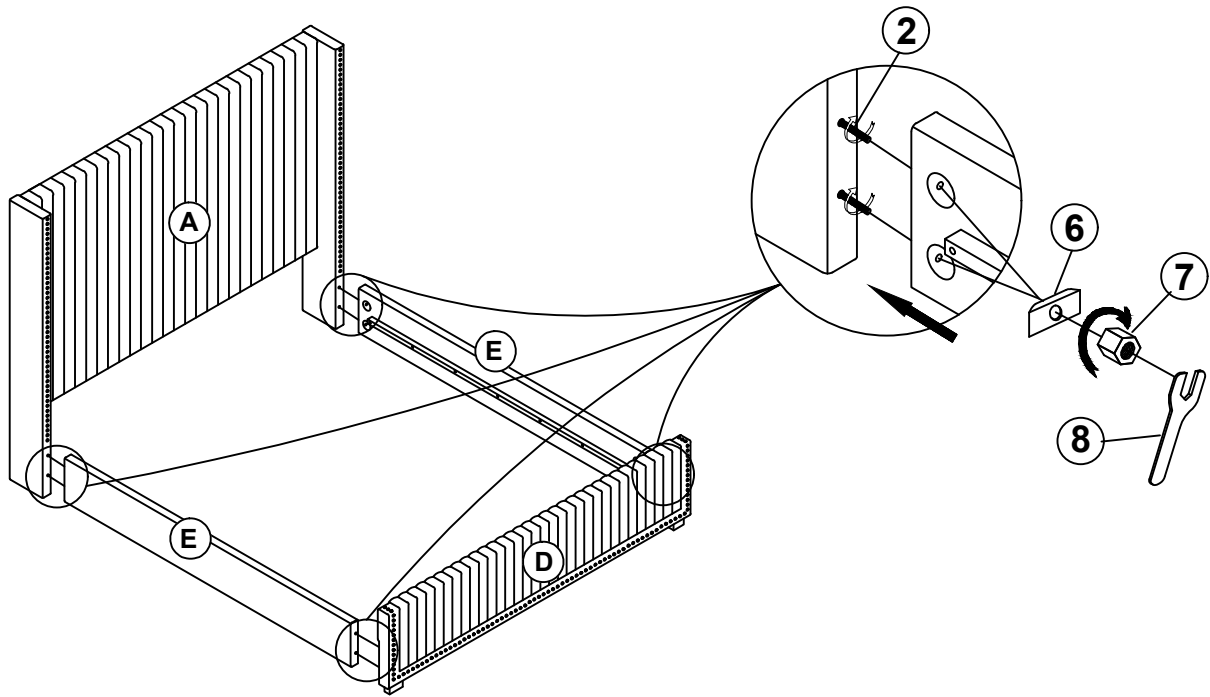

STEP 4

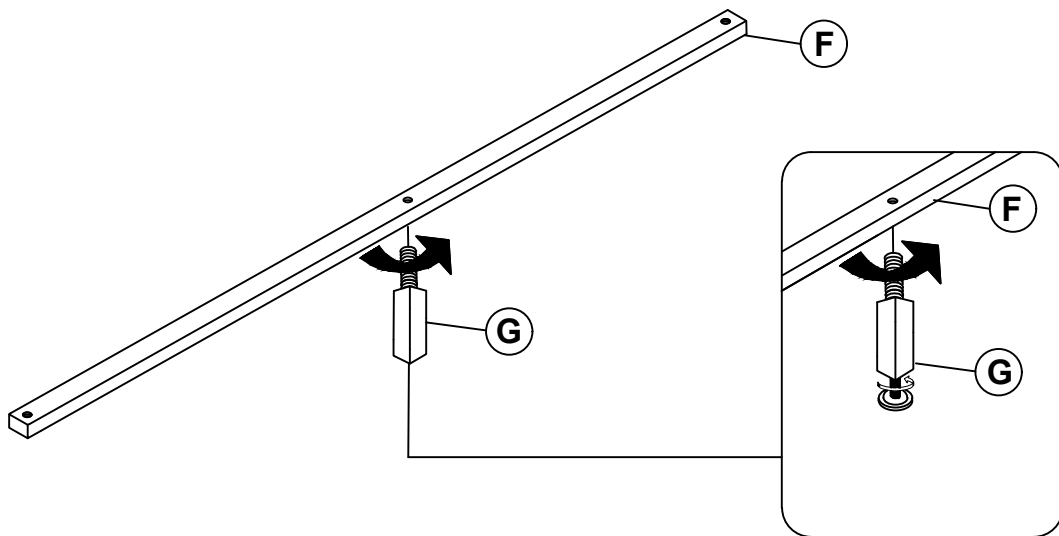

ITEM: **306051Q**

ASSEMBLY INSTRUCTIONS

STEP 5

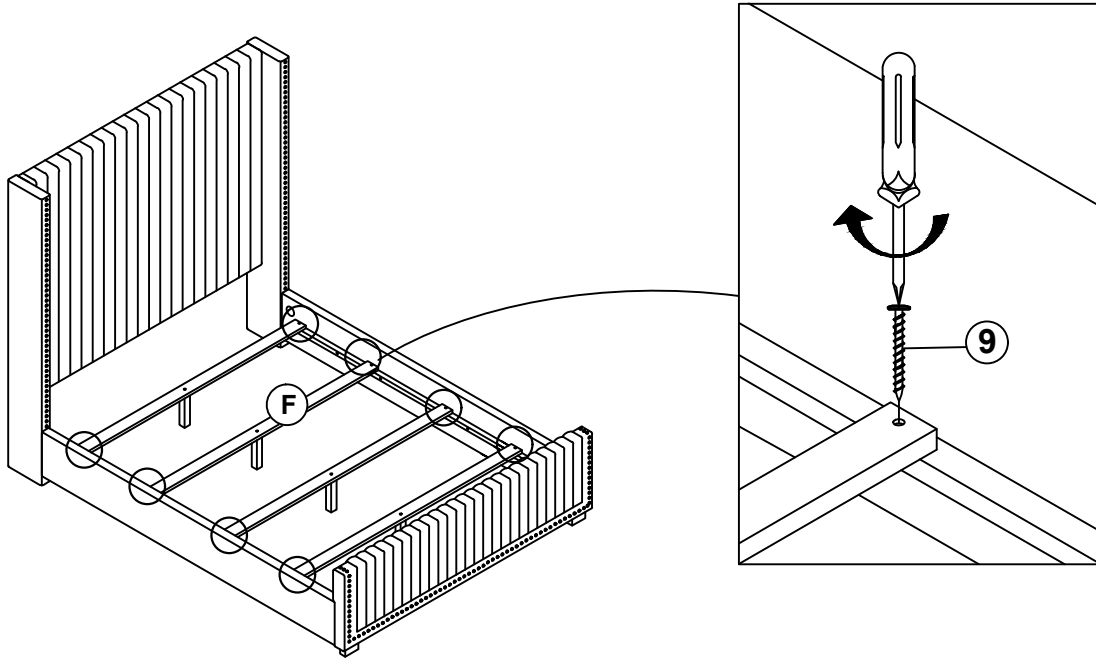

STEP 6
COMPLETE

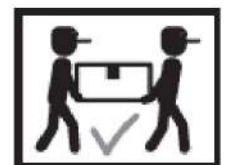
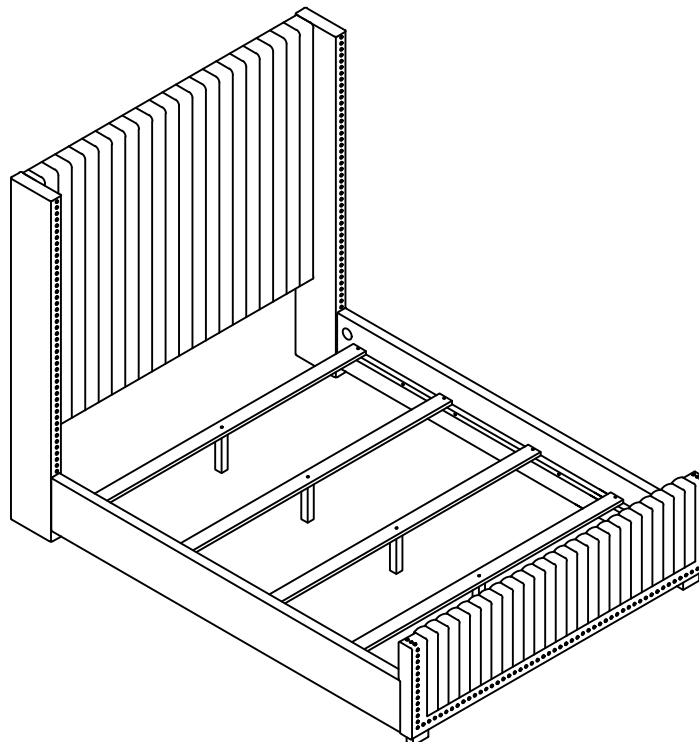

ITEM: **306051Q**



Inner Size: 61.00"W X 81.00"D

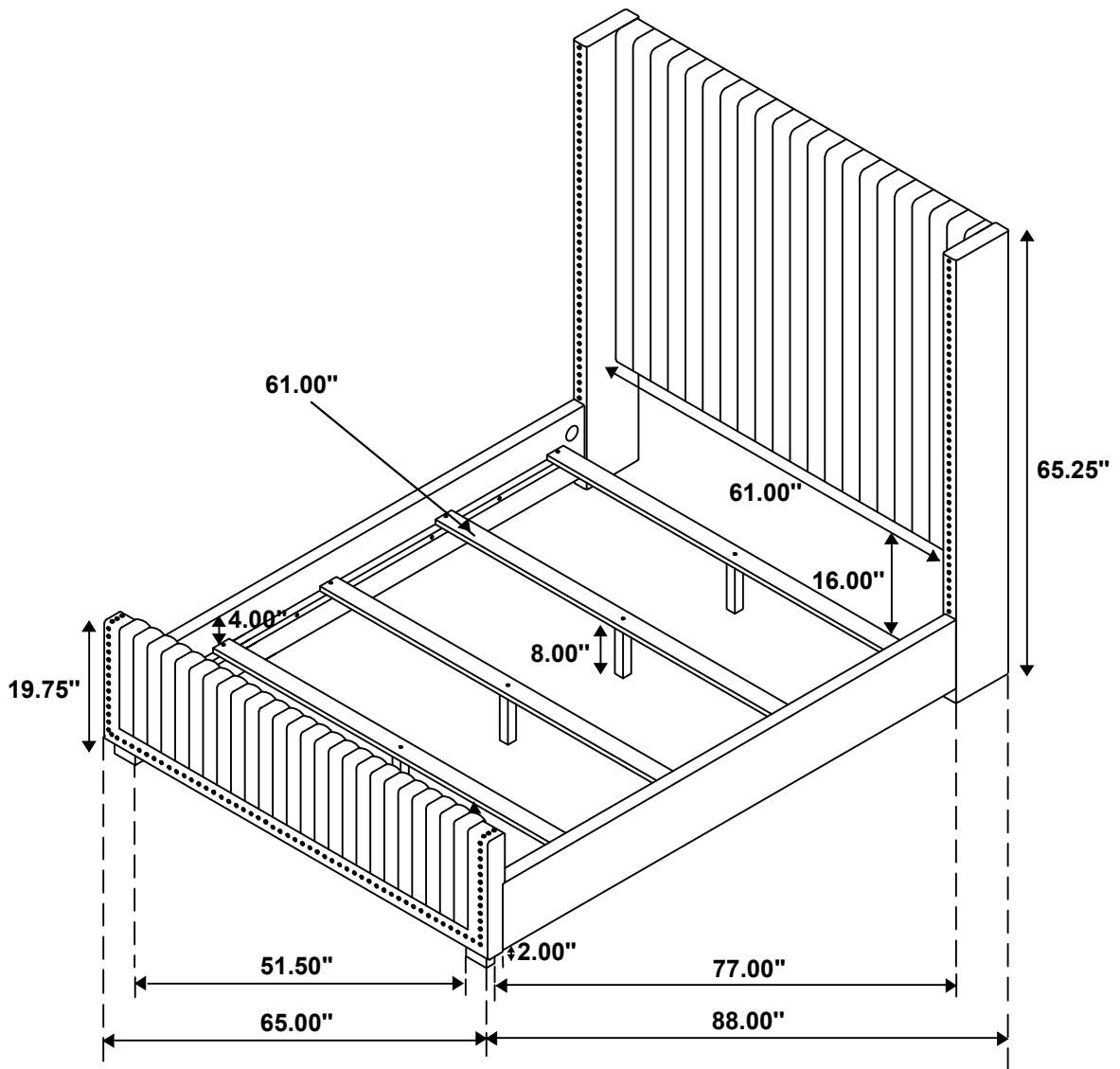

Note: Dimension tolerance $\pm 5\%$