

ASSEMBLY INSTRUCTIONS
COASTER FINE FURNITURE



Fine Furniture for every stage of life

360341Q(B1 & B2)
Queen Bed

ITEM: 360341Q(B1&B2)

ASSEMBLY INSTRUCTIONS

ASSEMBLY TIPS:

1. Remove hardware from box and sort by size.
2. Please check to see that all hardware and parts are present prior to start of assembly.
3. Please follow attached instructions in the same sequence as numbered to assure fast & easy assembly.

WARNING!



1. Don't attempt to repair or modify parts that are broken or defective. Please contact the store immediately.
2. This product is for home use only and not intended for commercial establishments.

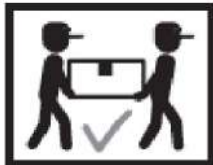

ASSEMBLY TIME

30 MINUTES

PARTS IDENTIFICATION

B1 (BOX 1)

A	HEADBOARD PANEL		1PC	B	HEADBOARD LEG		2PCS
---	-----------------	--	-----	---	---------------	--	------

B2 (BOX 2)

C	FOOTBOARD PANEL		1PC	D	FOOTBOARD LEG		2PCS
E	BED RAIL		2PCS	F	BED SLAT		4PCS
G	BED SLAT SUPPORT WITH LEVELER		4PCS				
HB	360341Q(B1) FROM BOX 1 HEADBOARD COMPLETE		1PC	FB	360341Q(B2) FROM BOX 2 FOOTBOARD COMPLETE		1PC

ITEM: 360341Q(B1&B2)

ASSEMBLY INSTRUCTIONS

ASSEMBLY TIPS:

1. Remove hardware from box and sort by size.
2. Please check to see that all hardware and parts are present prior to start of assembly.
3. Please follow attached instructions in the same sequence as numbered to assure fast & easy assembly.







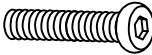

WARNING!

1. Don't attempt to repair or modify parts that are broken or defective. Please contact the store immediately.
2. This product is for home use only and not intended for commercial establishments.

HARDWARE IDENTIFICATION

Z-B2 (BOX 2) - HARDWARE PACK IS LOCATED IN 360341Q(B2)

1	ALLEN WRENCH (5mm - BLK)		1PC	2	BOLT (Ø 5/16" x 32mm - BLK)		24PCS
3	HEADBOARD CORNER BRACKET - RIGHT (200mm x 60mm x 40mm x2mm - BLK)		2PCS	4	HEADBOARD CORNER BRACKET - LEFT (200mm x 60mm x 40mm x2mm - BLK)		2PCS
5	LOCK WASHER (Ø 5/16" -BLK)		24PCS	6	FLAT WASHER (Ø 5/16" - BLK)		24PCS
7	FLAT HEAD SCREW (M4 x 30mm - BLK)		8PCS				

NOTE:

Phillips head screw driver is required in the assembly process; however, manufacturer does not provide this item.

ITEM: **360341Q(B1&B2)**

ASSEMBLY INSTRUCTIONS

STEP 1

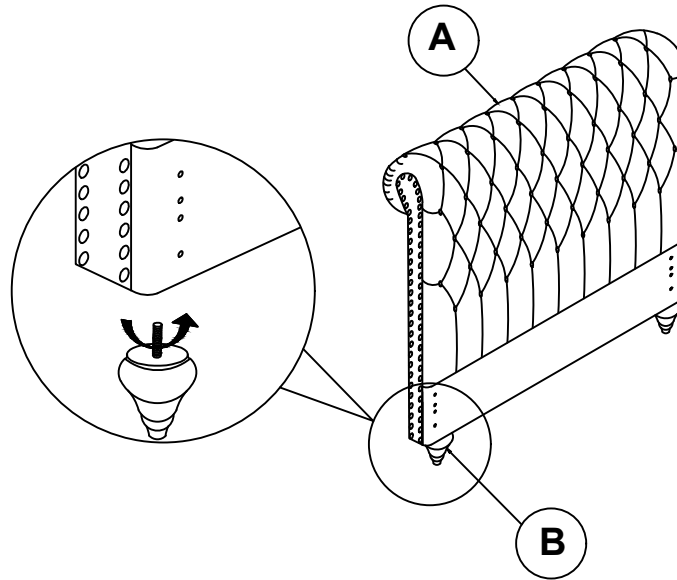

STEP 2

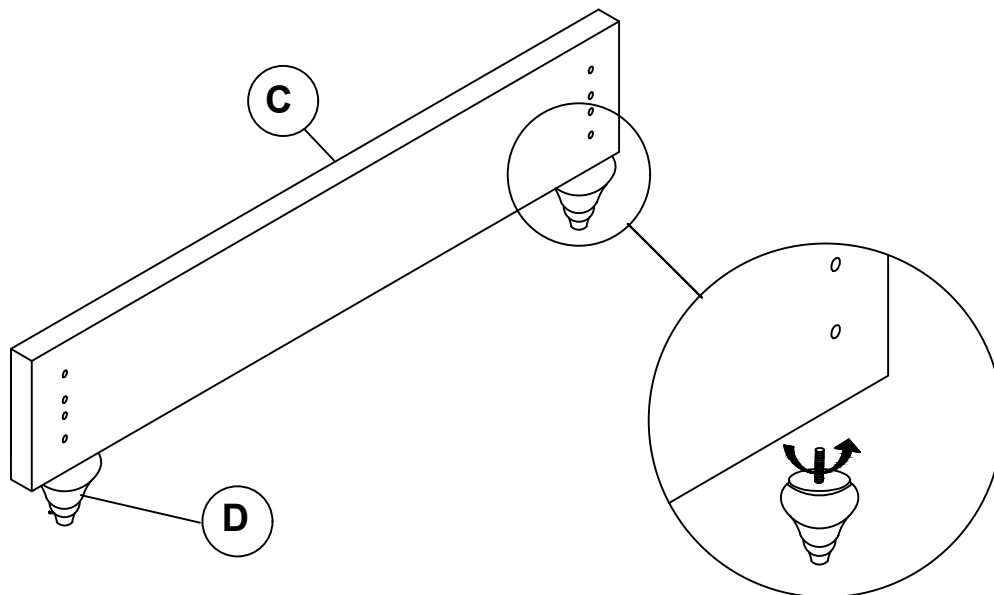

ITEM: 360341Q(B1&B2)

ASSEMBLY INSTRUCTIONS

STEP 3

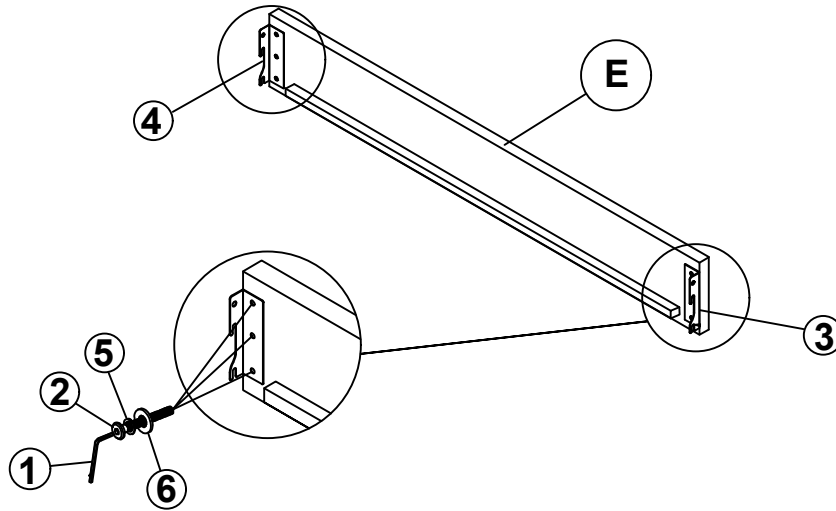

STEP 4

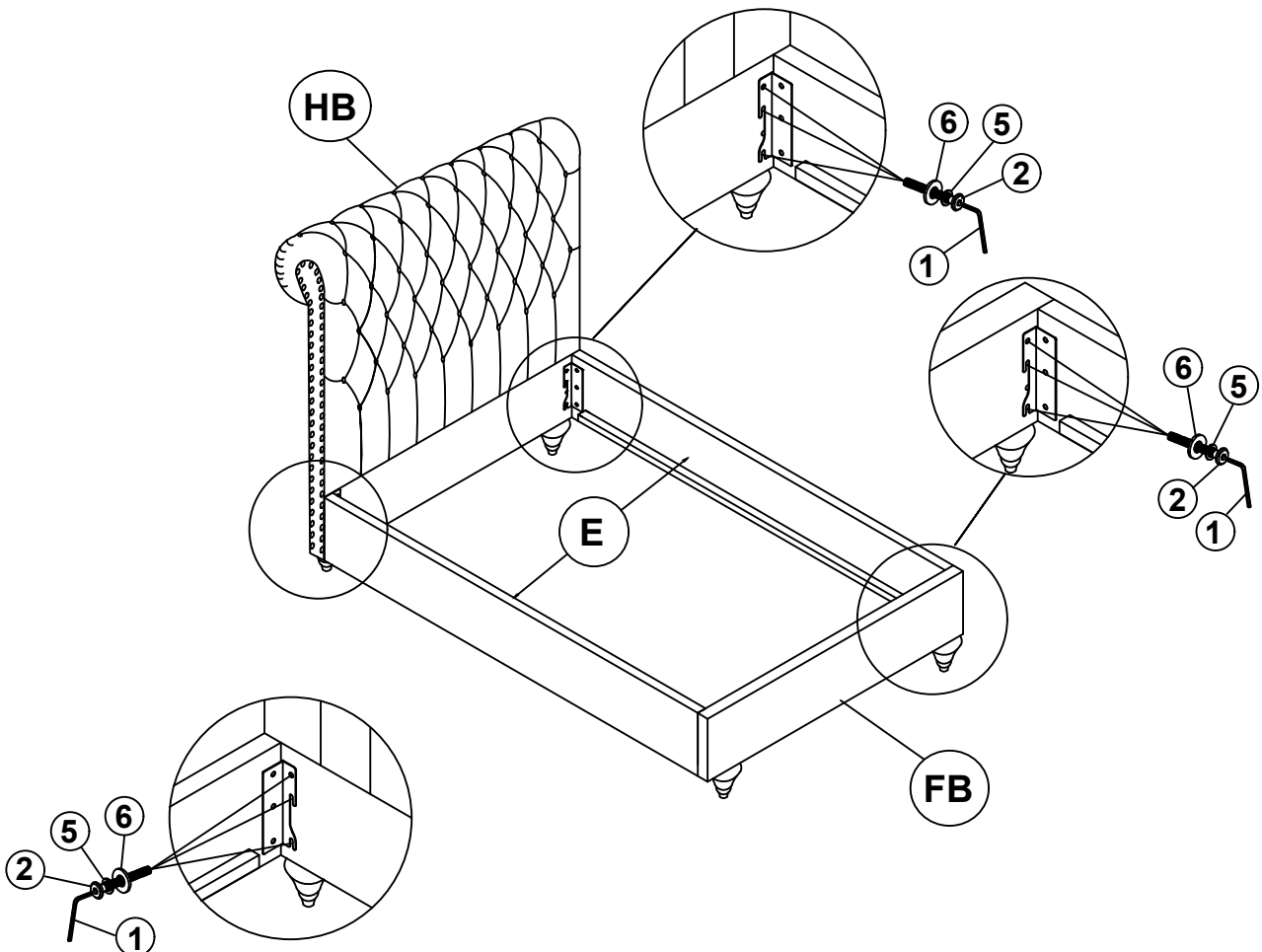

ITEM: 360341Q(B1&B2)

ASSEMBLY INSTRUCTIONS



STEP 5

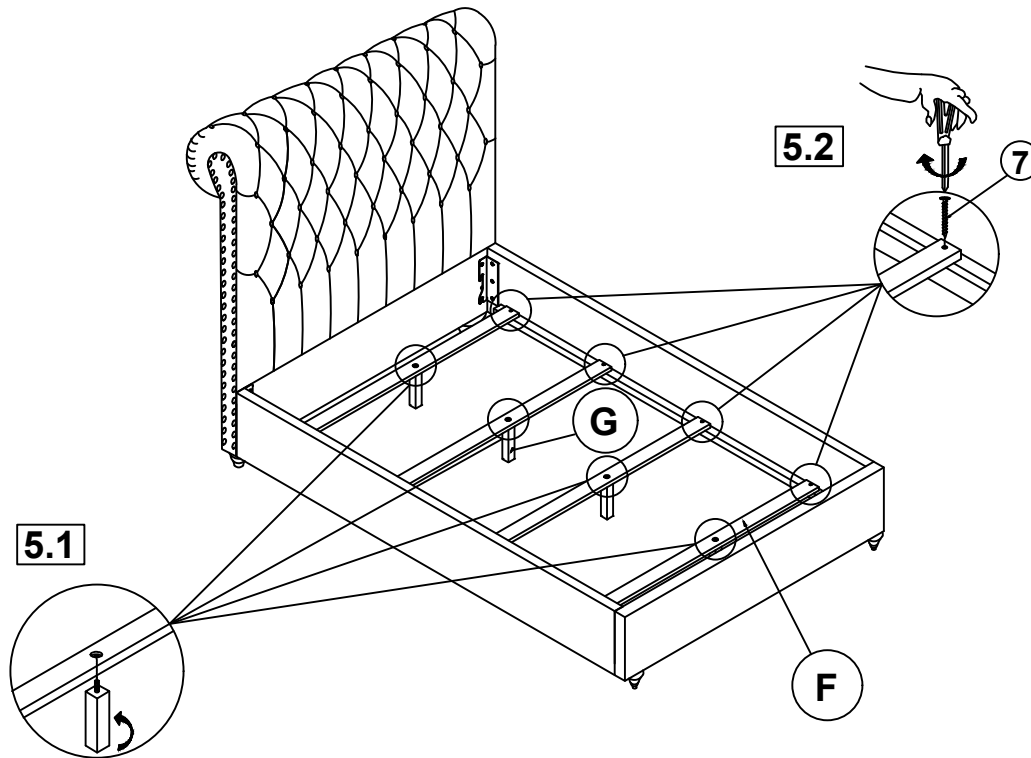

STEP 6 COMPLETE

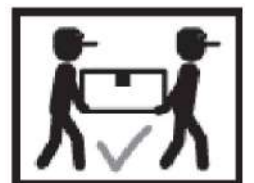
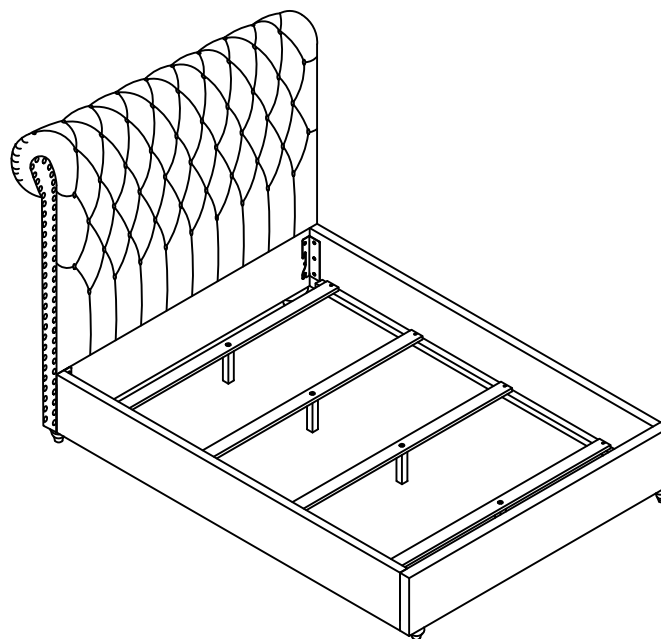

ITEM: 360341Q(B1&B2)

Inner Size : 61.00"W x 81.00"D

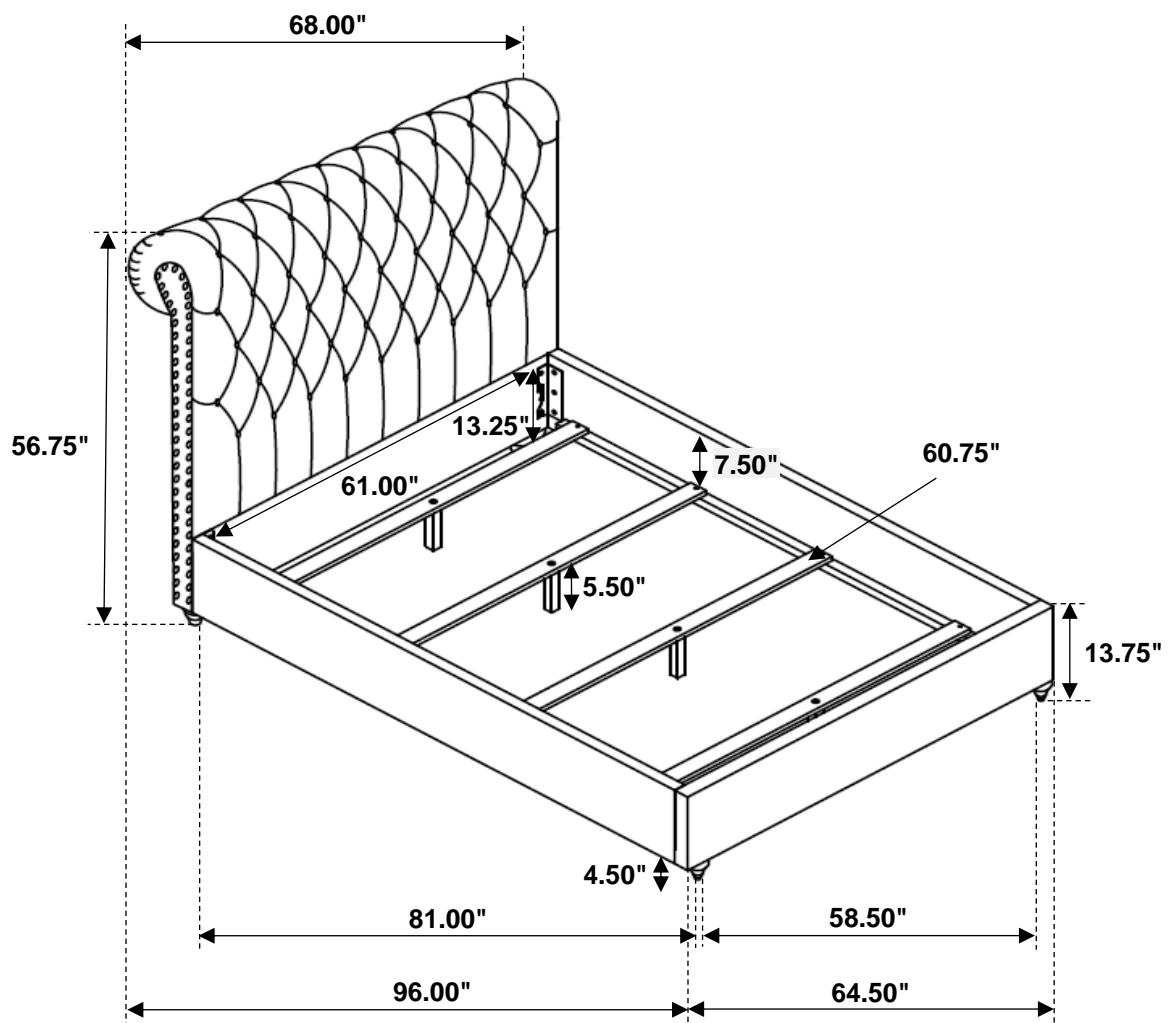

Note: Dimension tolerance $\pm 5\%$