

*ASSEMBLY INSTRUCTIONS
COASTER FINE FURNITURE*



Fine Furniture for every stage of life

182105
BAR UNIT

ITEM: 182105

ASSEMBLY INSTRUCTIONS

ASSEMBLY TIPS:

1. Remove hardware from box and sort by size.
2. Please check to see that all hardware and parts are present prior to start of assembly.
3. Please follow attached instructions in the same sequence as numbered to assure fast & easy assembly.
4. *****Please keep the 2 long pieces of 30mm Styrofoam included in the package as cushioning pads during this assembly step.*****



WARNING!

1. Don't attempt to repair or modify parts that are broken or defective. Please contact the store immediately.
2. This product is for home use only and not intended for commercial establishments.



ASSEMBLY TIME

90 MINUTES

PARTS IDENTIFICATION

A LEFT SIDE PANEL

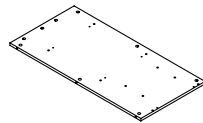

1 PC

B RIGHT SIDE PANEL

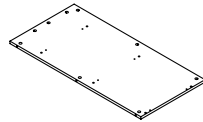

1 PC

C UPPER DIVIDER PANEL

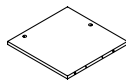

3 PCS

D LOWER DIVIDER PANEL

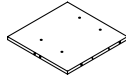

1 PC

E SMALL DIVIDER PANEL

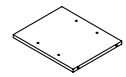

3 PCS

F SMALL CROSS PANEL



8 PCS

G BOTTOM PANEL

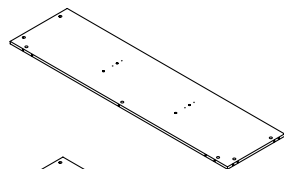

1 PC

H MIDDLE CROSS PANEL

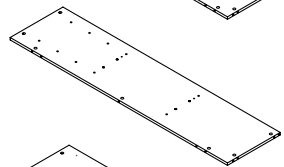

1 PC

I UPPER CROSS PANEL

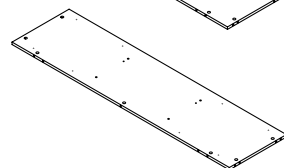

1 PC

J LARGE TOP PANEL

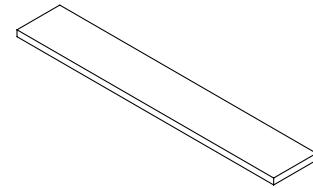

1 PC

K LEFT SMALL TOP PANEL

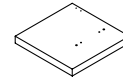

1 PC

L RIGHT SMALL TOP PANEL

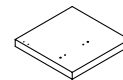

1 PC

M LOWER BACK PANEL

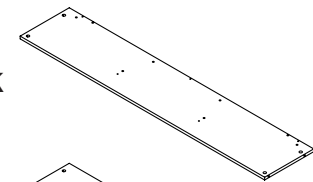

1 PC

N MIDDLE BACK PANEL

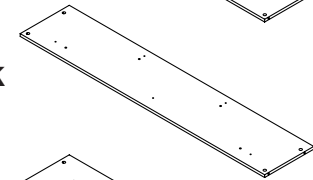

1 PC

O UPPER BACK PANEL

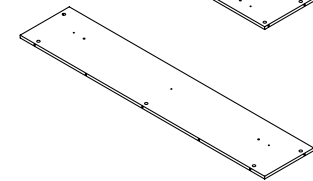

1 PC

P LEFT FRONT LEG

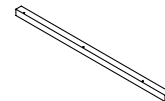

1 PC

Q LEFT BACK LEG

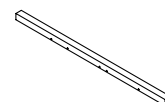

1 PC

R RIGHT FRONT LEG

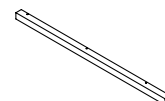

1 PC

NOTE:

Phillips head screw driver is required in the assembly process; however, manufacturer does not provide this item.

ITEM: 182105

S RIGHT BACK LEG

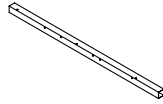





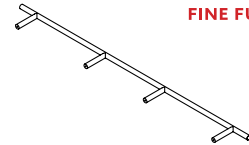





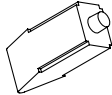
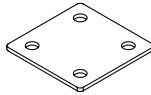
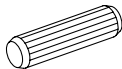

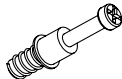
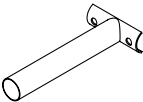

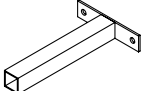
1 PC

T FOOTREST

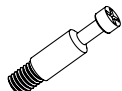

1 PC

HARDWARE IDENTIFICATION

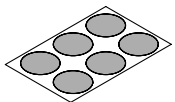
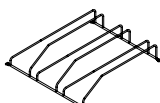
| Z NO | DESCRIPTION | FIGURE | Q'TY | Z NO | DESCRIPTION | FIGURE | Q'TY |
|------|---------------------------|---|--------|------|-----------------------------------|---|--------|
| 1 | GLUE 40g |  | 1 PC | 12 | SUPPORT PLATE SR |  | 2 PCS |
| 2 | WOODEN DOWEL Ø8x30mm |  | 58 PCS | 13 | SCREW Ø4x15mm SR |  | 16 PCS |
| 3 | CAM BOLT Ø7x35.5mm SR |  | 38 PCS | 14 | FOOTREST SUPPORT LEG Ø25mm BLK |  | 3 PCS |
| 4 | CAM LOCK Ø15x12mm SR |  | 60 PCS | 15 | SUPPORT LEG 129mm BLK |  | 2 PCS |
| 5 | SCREW Ø4.5x42mm SR |  | 8 PCS | 16 | SCREW Ø4x15mm BLK |  | 4 PCS |
| 6 | WOODEN DOWEL Ø8x50mm |  | 16 PCS | 17 | FLOOR PROTECTOR 38x38mm |  | 4 PCS |
| 7 | CAM BOLT Ø7x31.5mm BLK |  | 22 PCS | 18 | FLOOR PROTECTOR 18x18mm |  | 2 PCS |
| 8 | BOLT M6x38mm BLK |  | 4 PCS | 19 | FLOOR PROTECTOR Ø25mm |  | 5 PCS |
| 9 | BOLT M6x15mm BLK |  | 6 PCS | 20 | SCREW DRIVER |  | 1 PC |
| 10 | ALLEN WRENCH 4mm SR |  | 1 PC | 21 | STICKER Ø20mm |  | 10 PCS |
| 11 | GLASS HOLDER |  | 2 PCS | | | | |

Z11,Z14,Z15 not included in blister packaging.

NOTE:

Phillips head screw driver is required in the assembly process; however, manufacturer does not provide this item.

ITEM: **182105**

COASTER
FINE FURNITURE

STEP 1

- 2 x 23
- 4 x 2
- 6 x 12

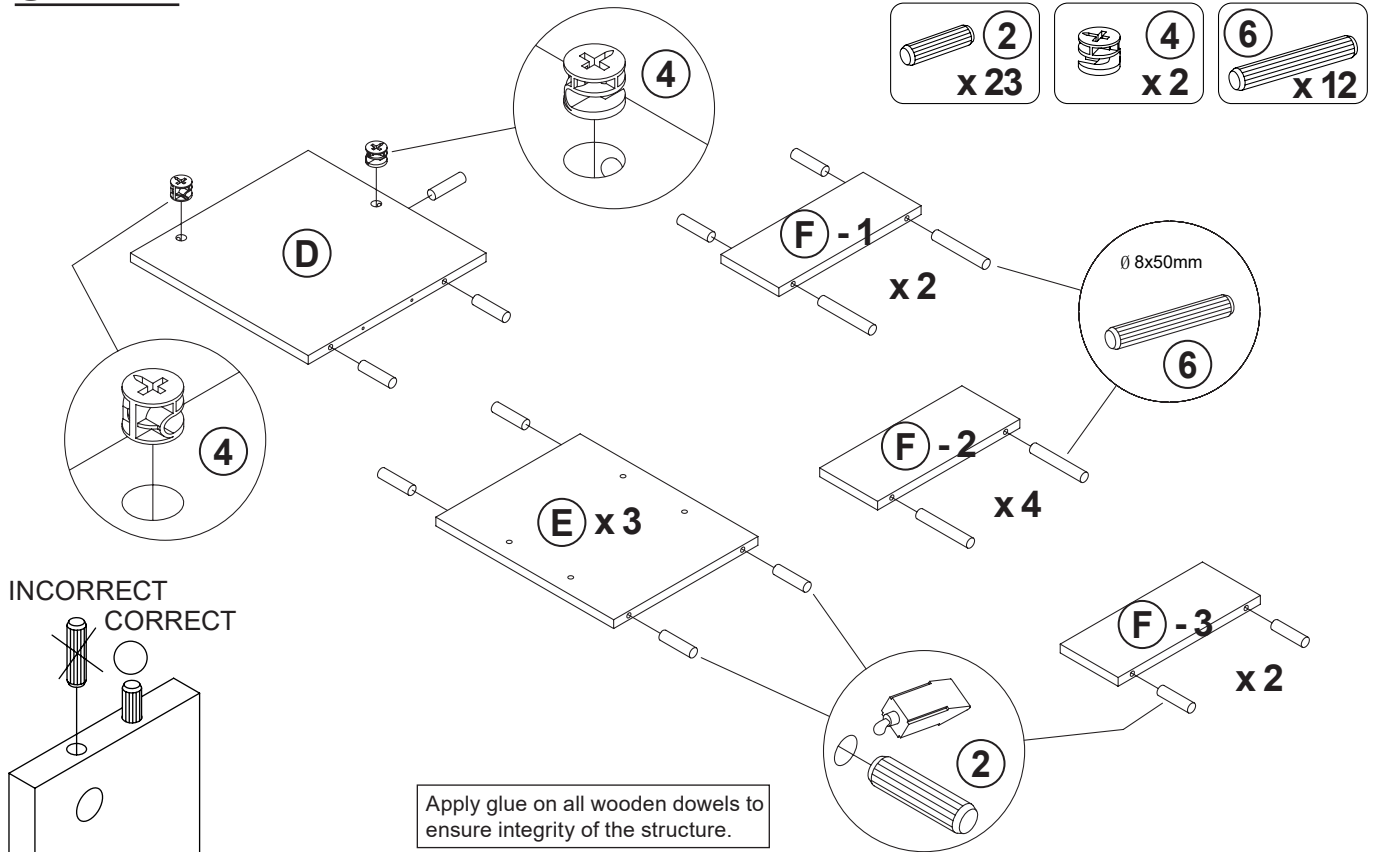

STEP 2

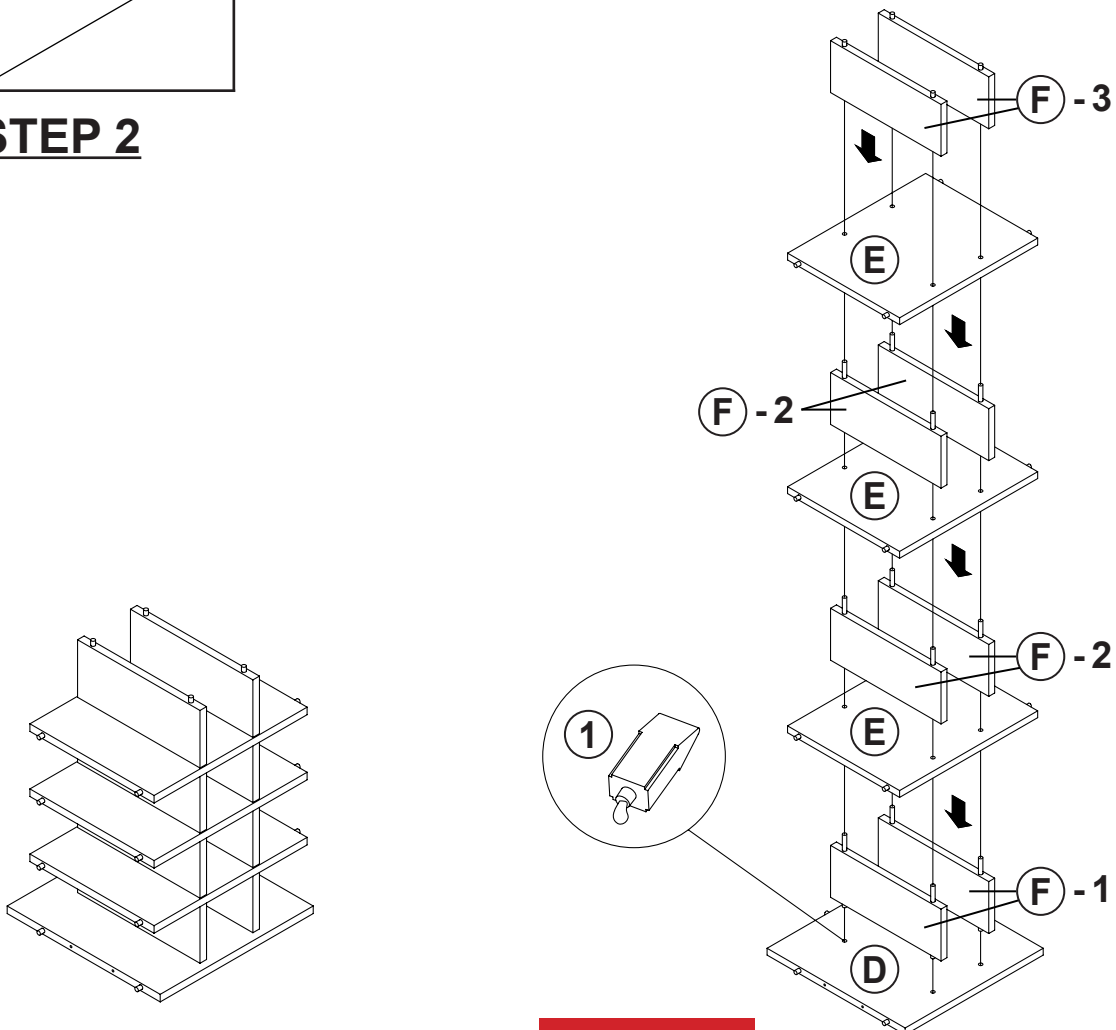

ITEM: 182105

COASTER
FINE FURNITURE

STEP 3

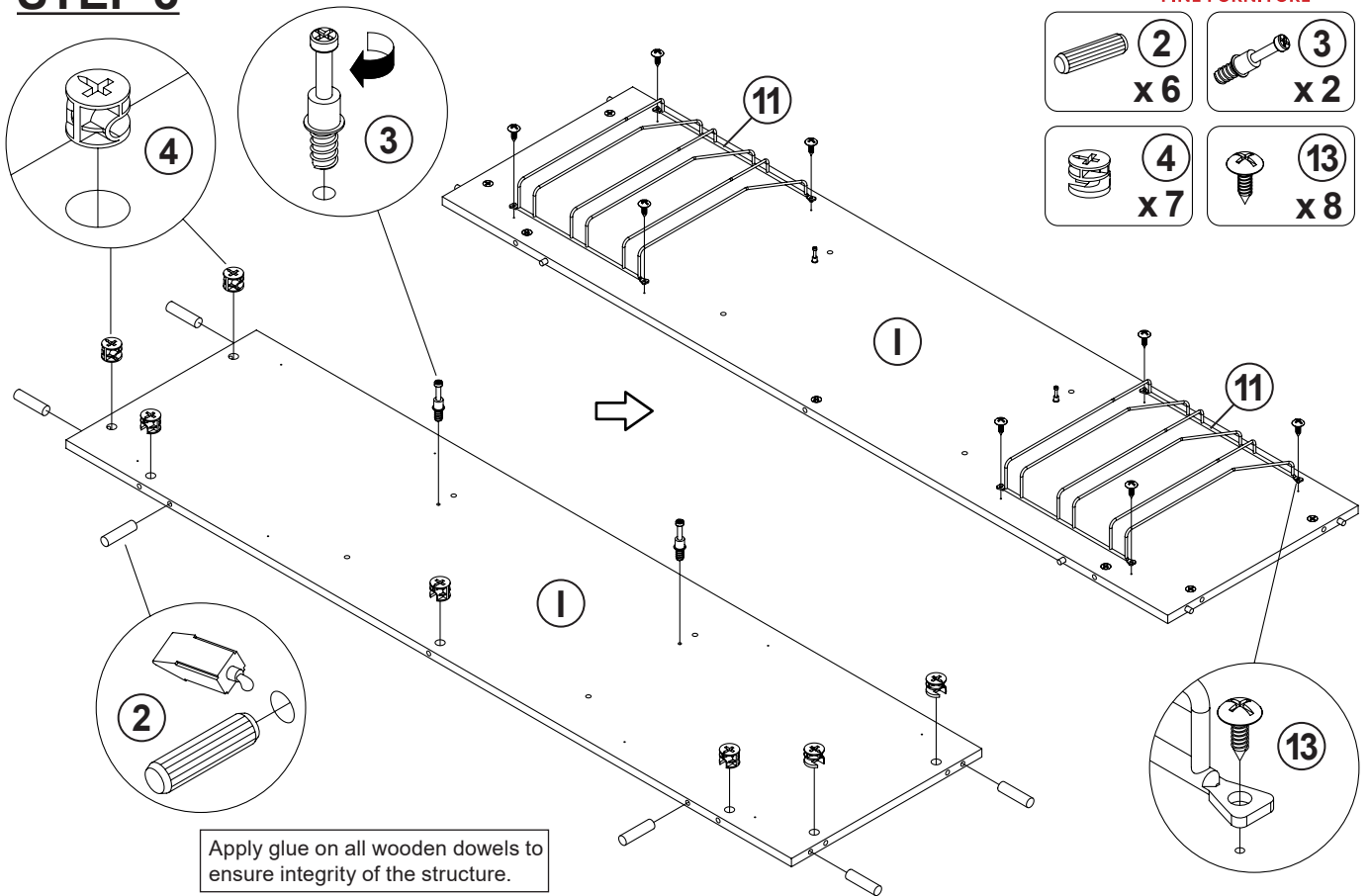

STEP 4

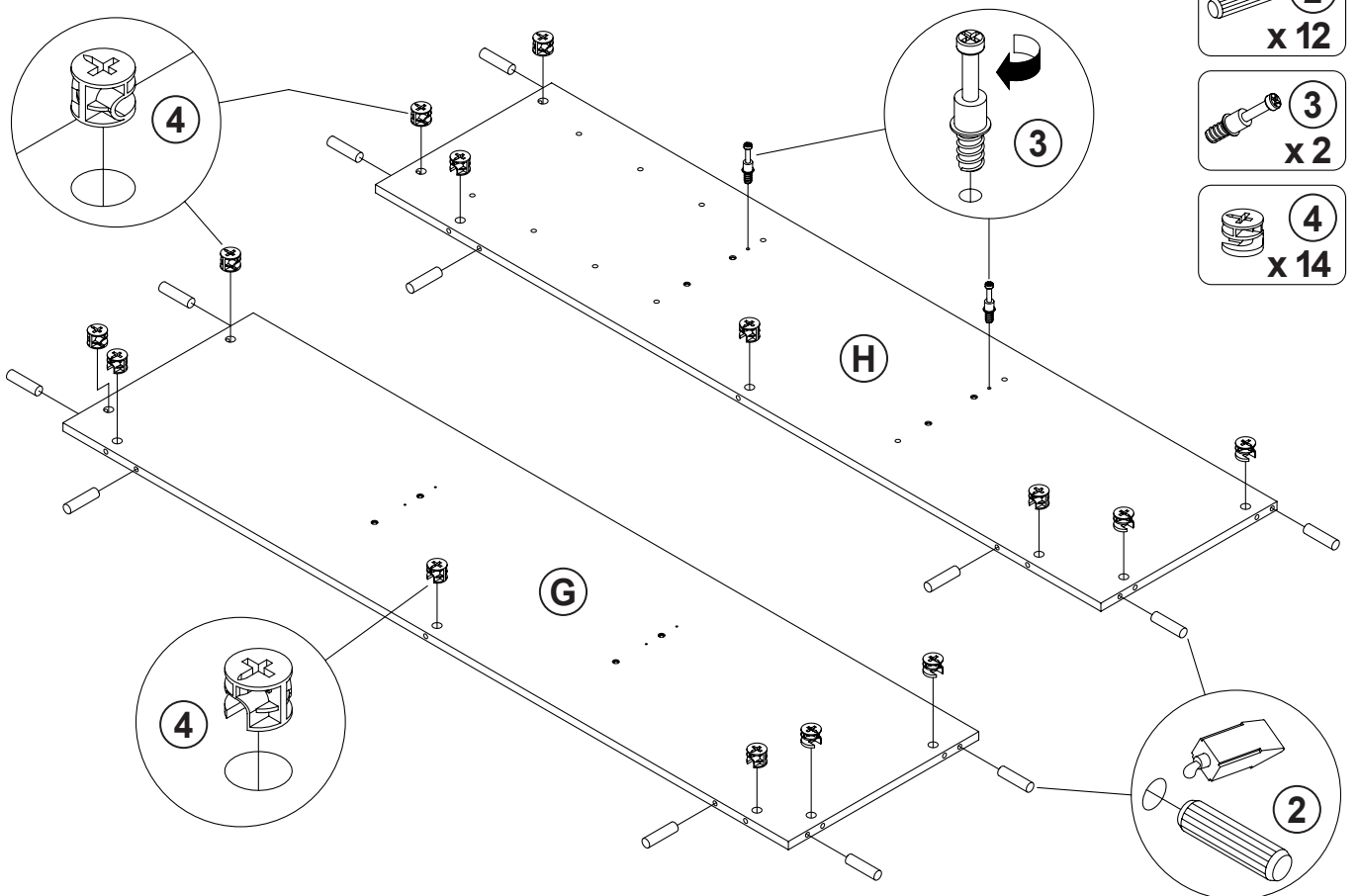

ITEM: 182105

COASTER
FINE FURNITURE

STEP 5

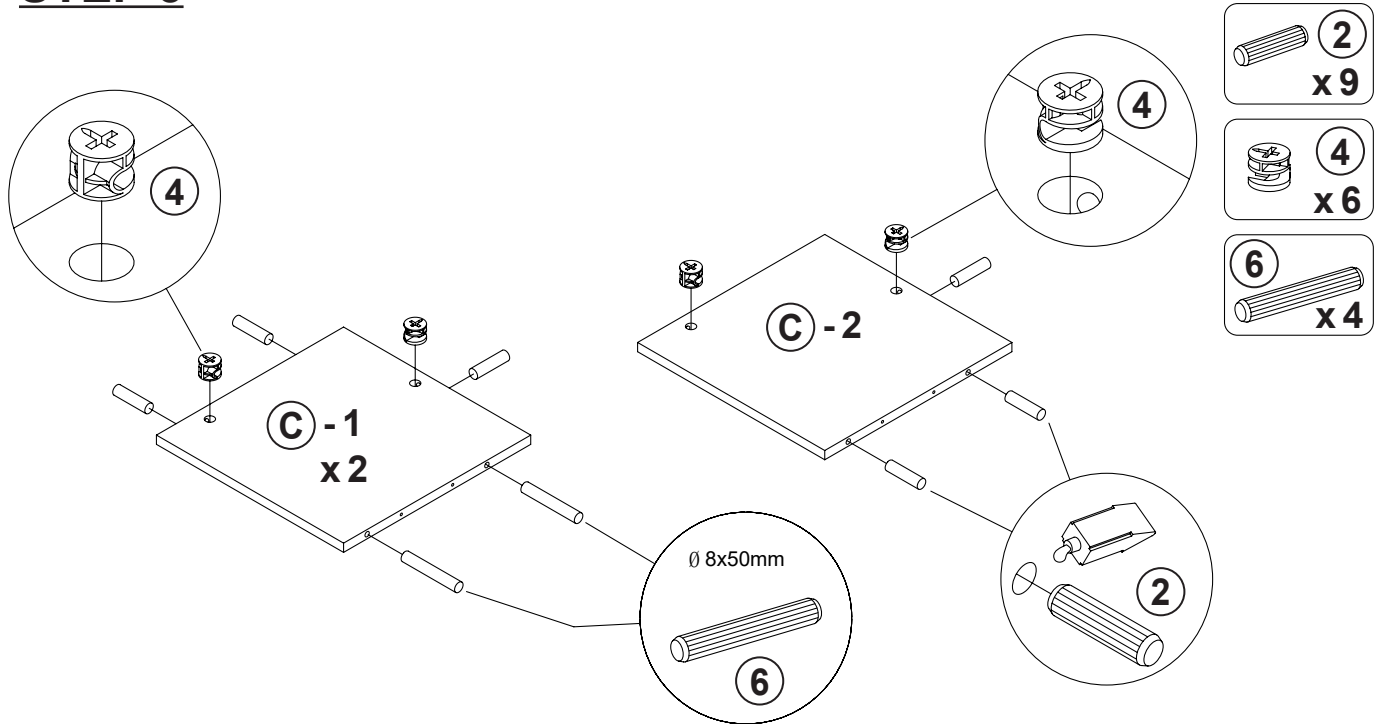

STEP 6

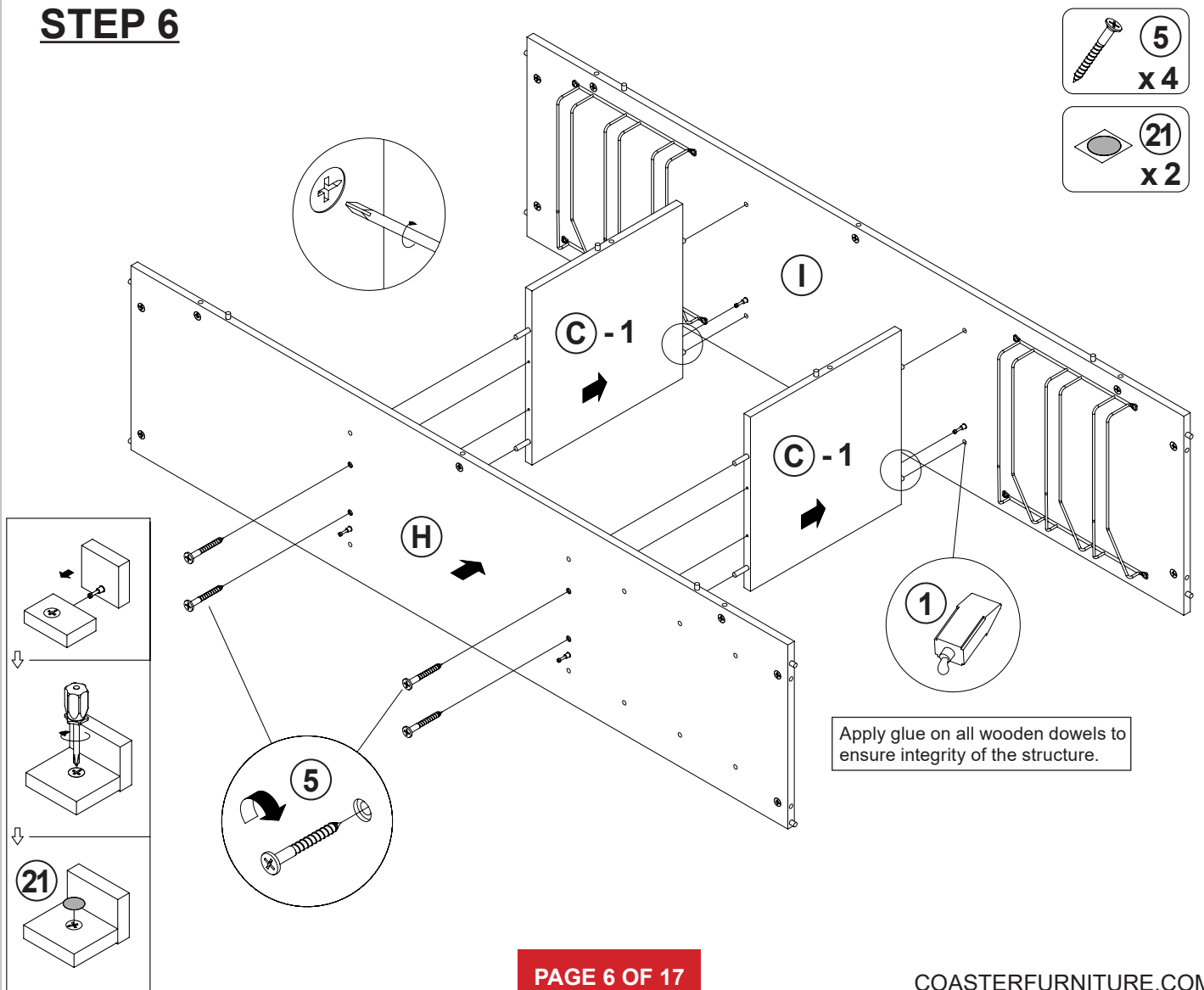

ITEM: 182105

COASTER
FINE FURNITURE

STEP 7

5
x 4

21
x 2

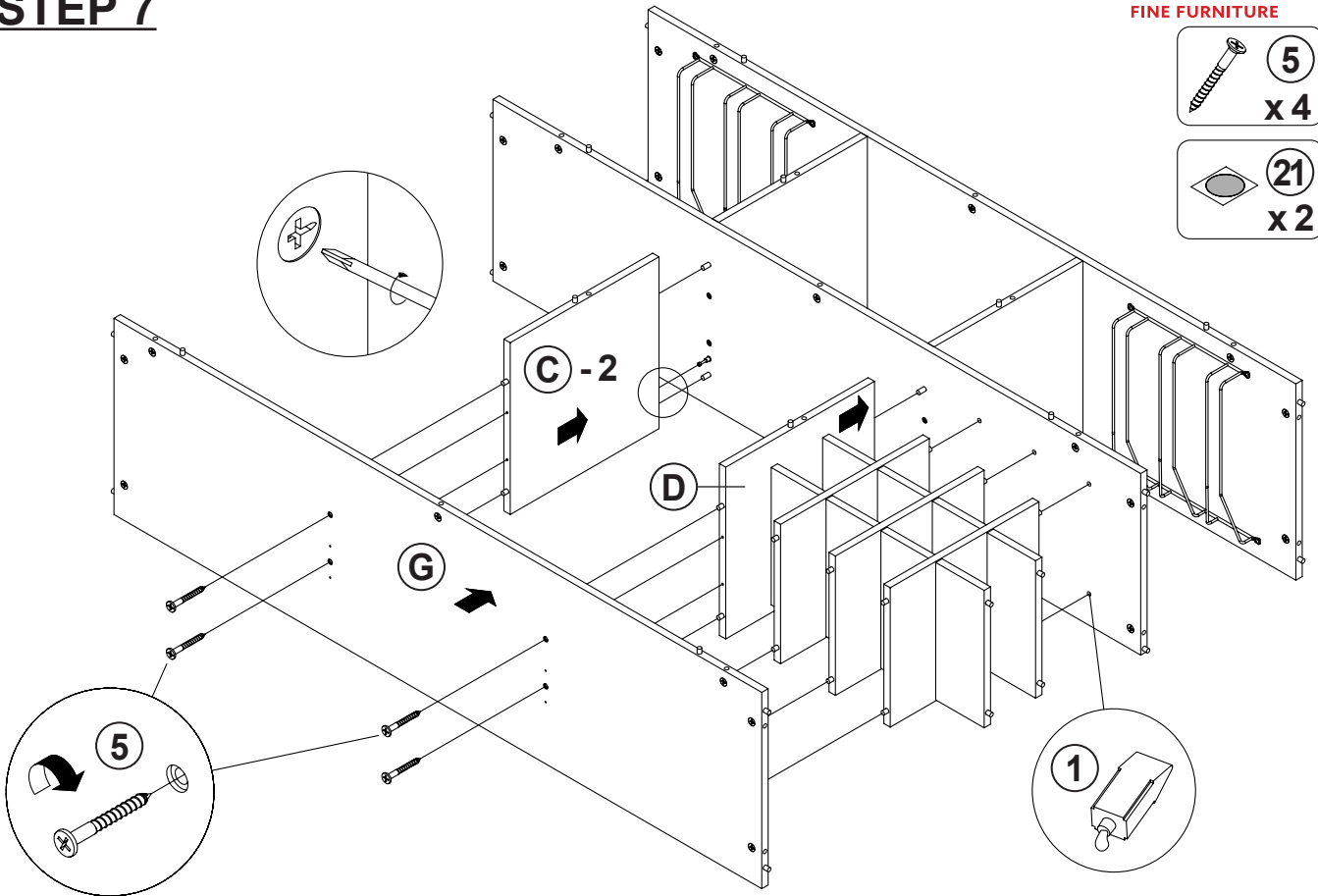

STEP 8

2
x 2

3
x 8

4
x 9

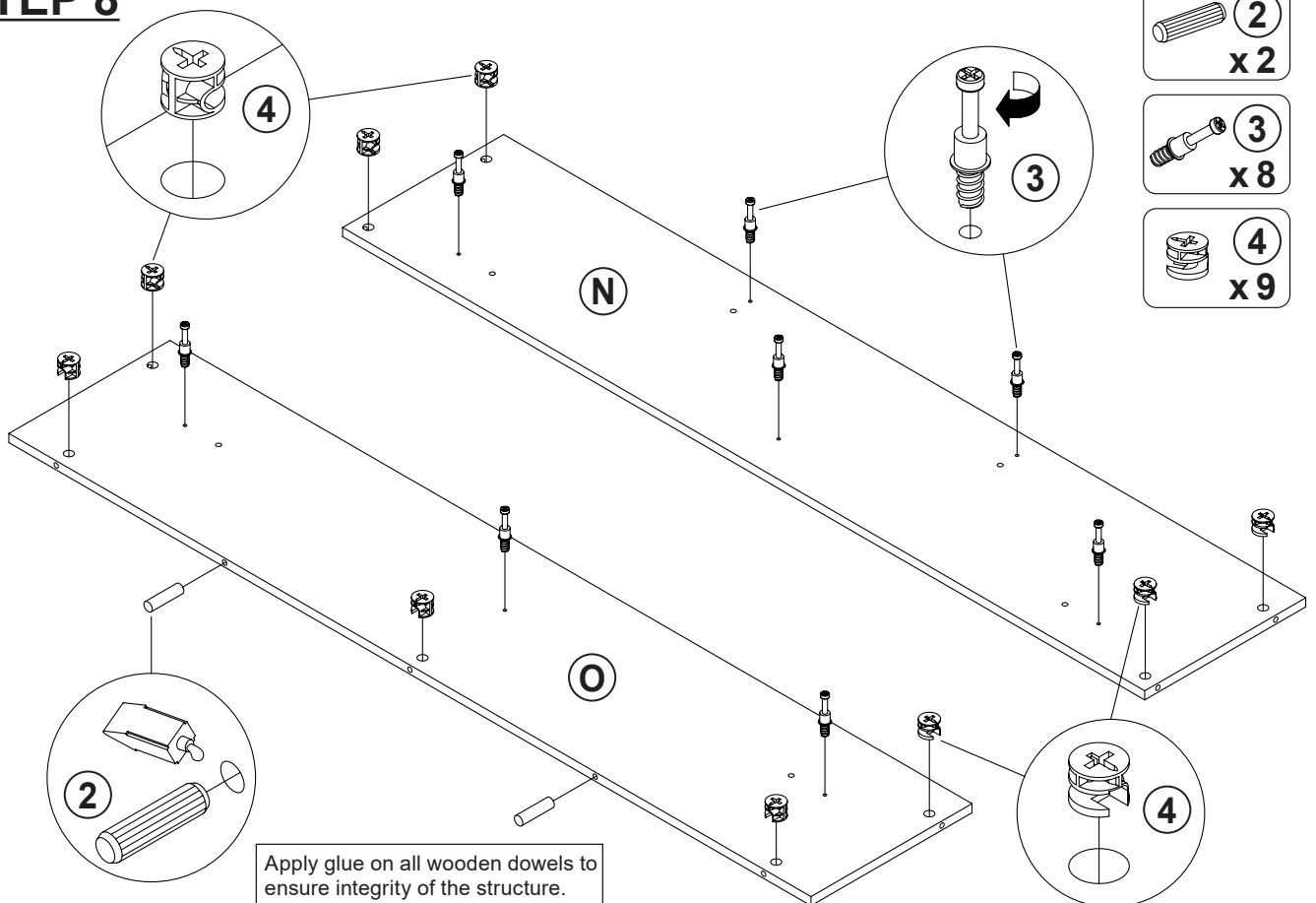

ITEM: **182105**

COASTER
FINE FURNITURE

STEP 9

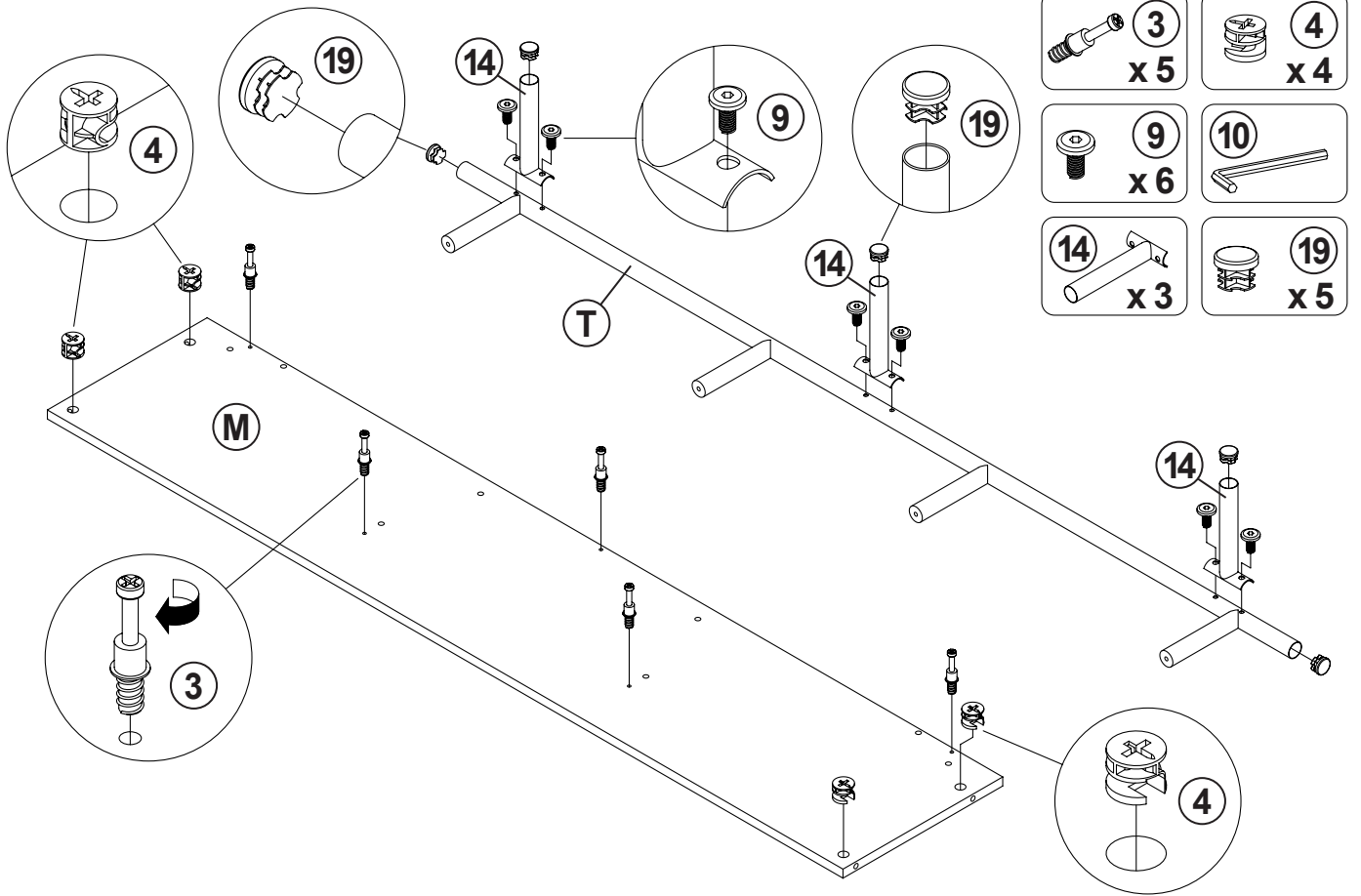

STEP 10

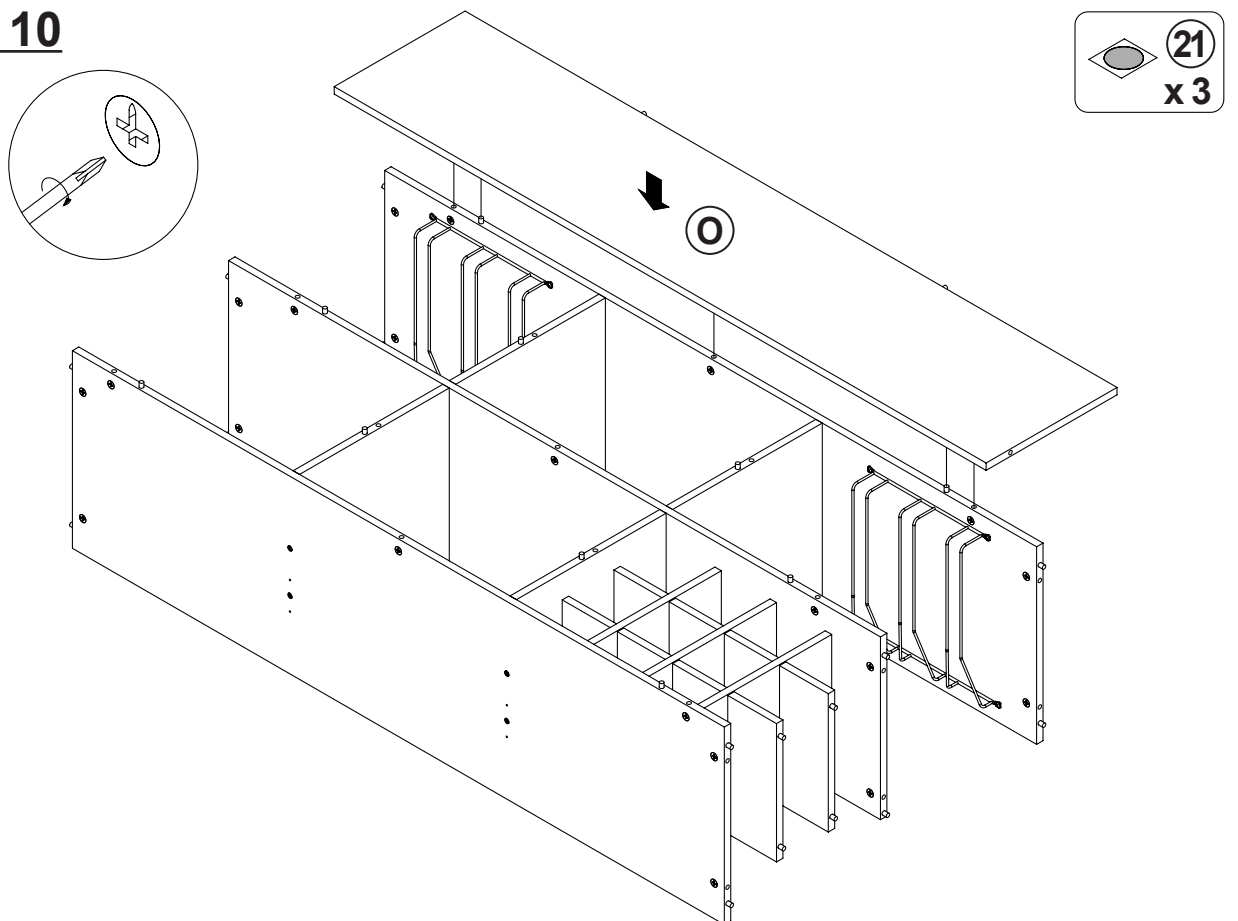

ITEM: **182105**

COASTER
FINE FURNITURE

STEP 11

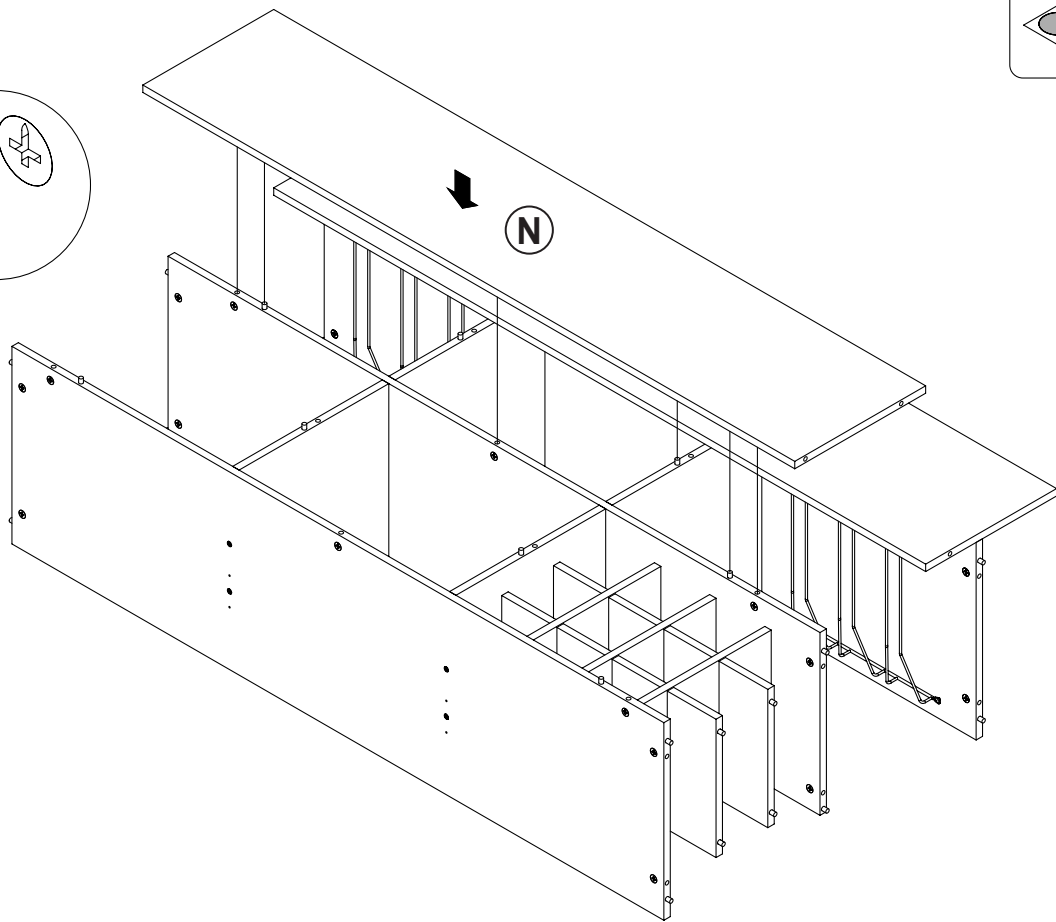
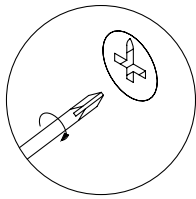
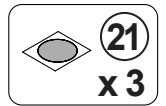

STEP 12

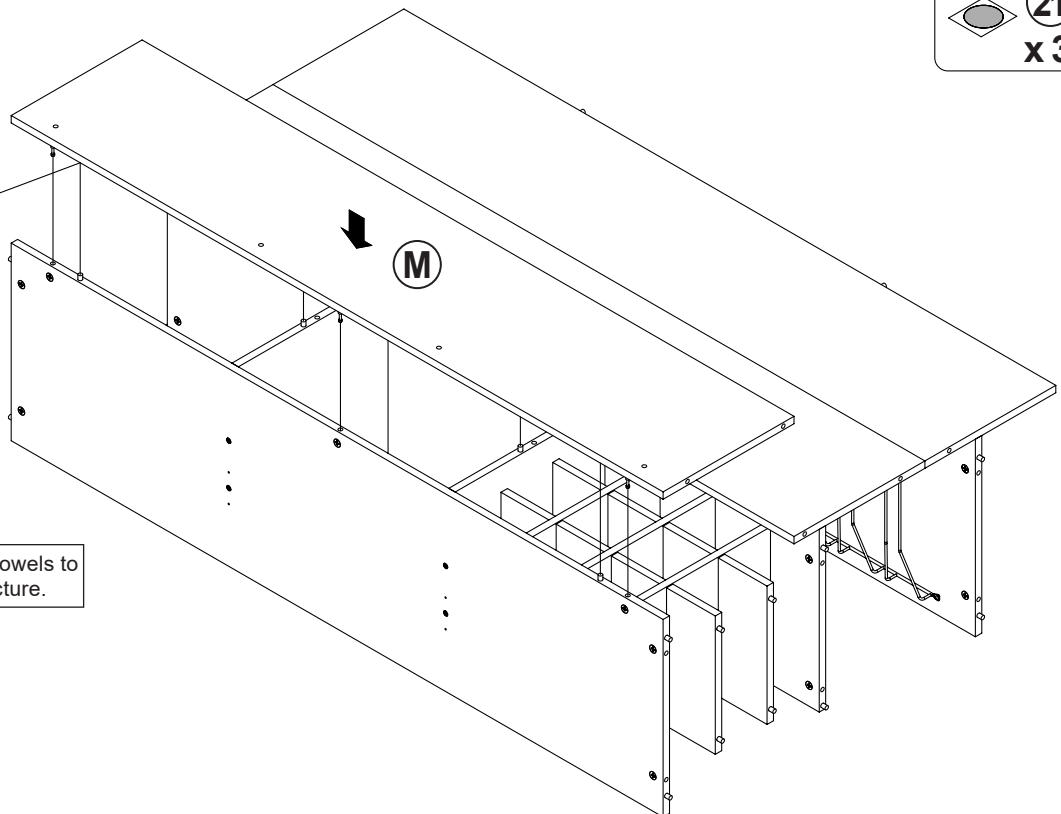
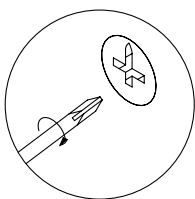
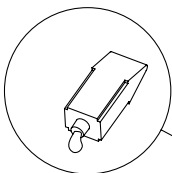
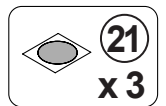

Apply glue on all wooden dowels to ensure integrity of the structure.

ITEM: **182105**

STEP 13

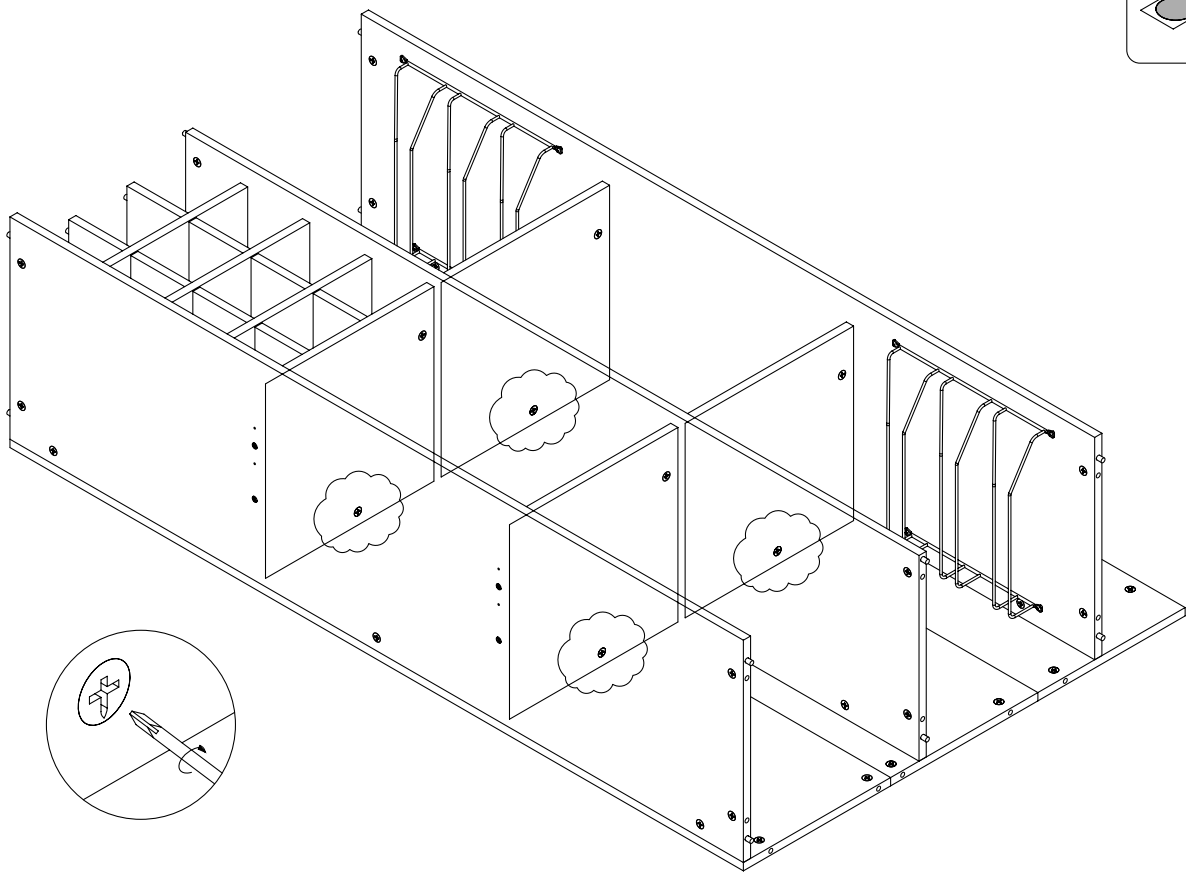
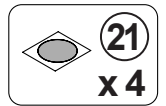

STEP 14

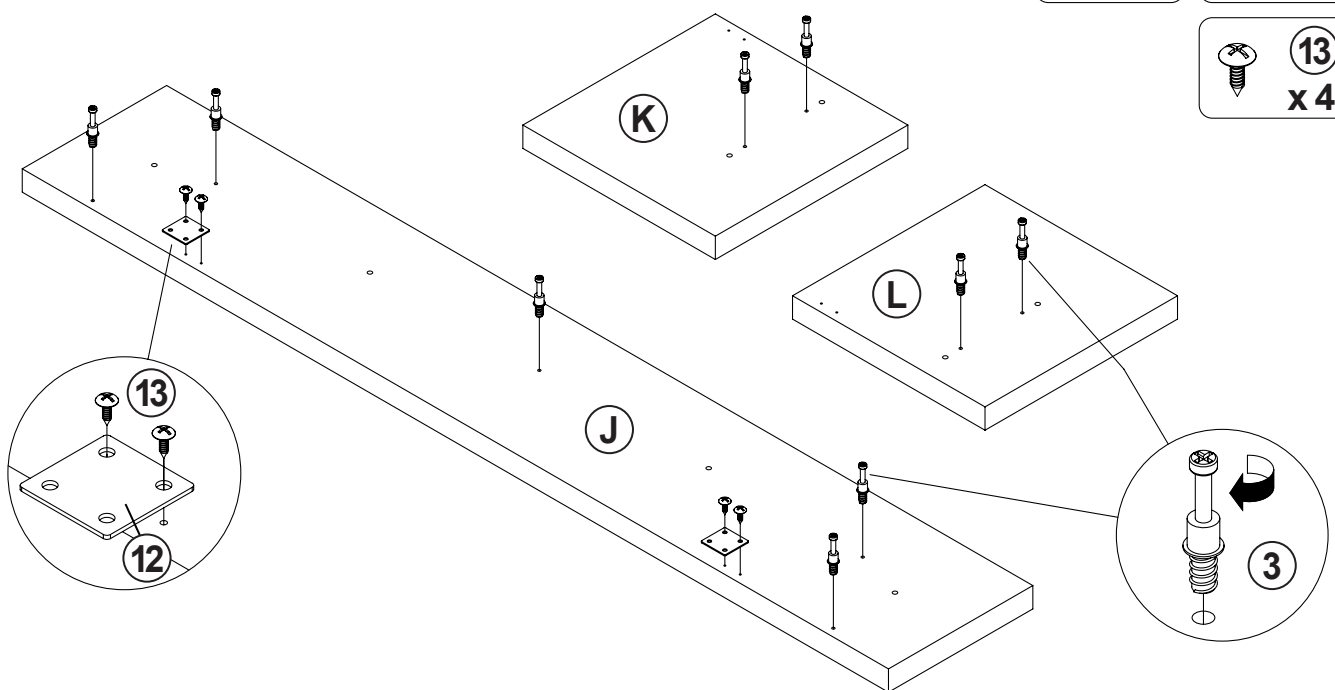
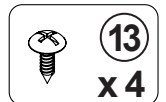
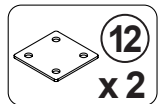
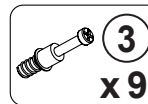

ITEM: 182105

COASTER
FINE FURNITURE

STEP 15

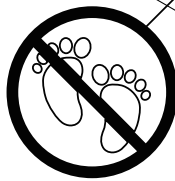
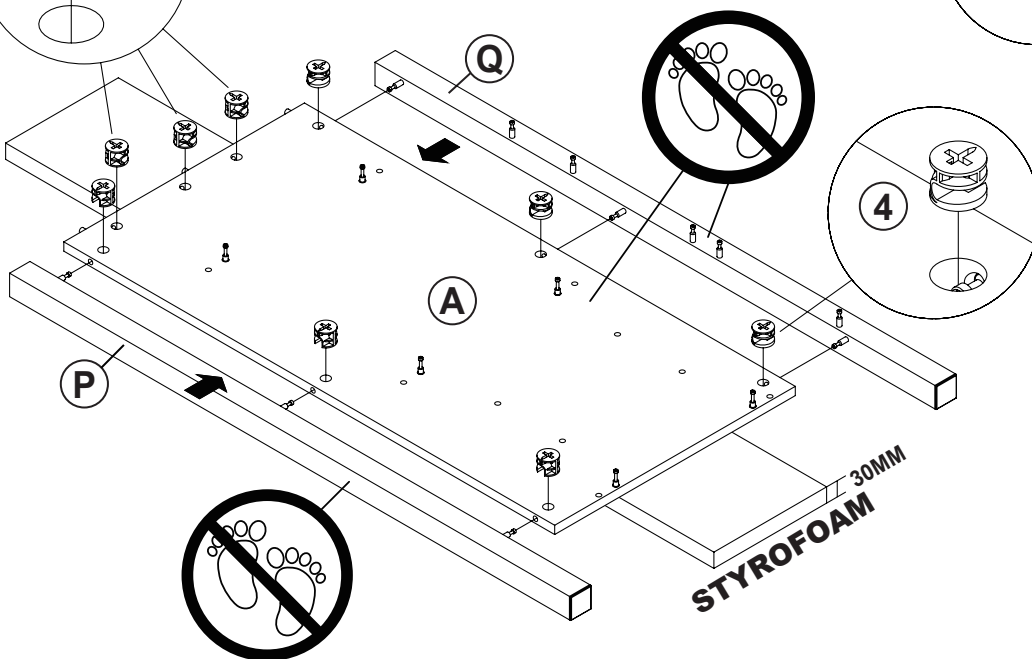
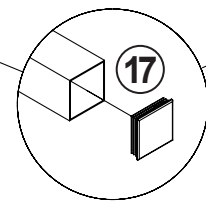
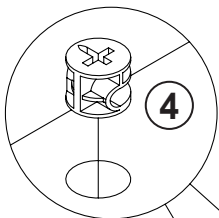
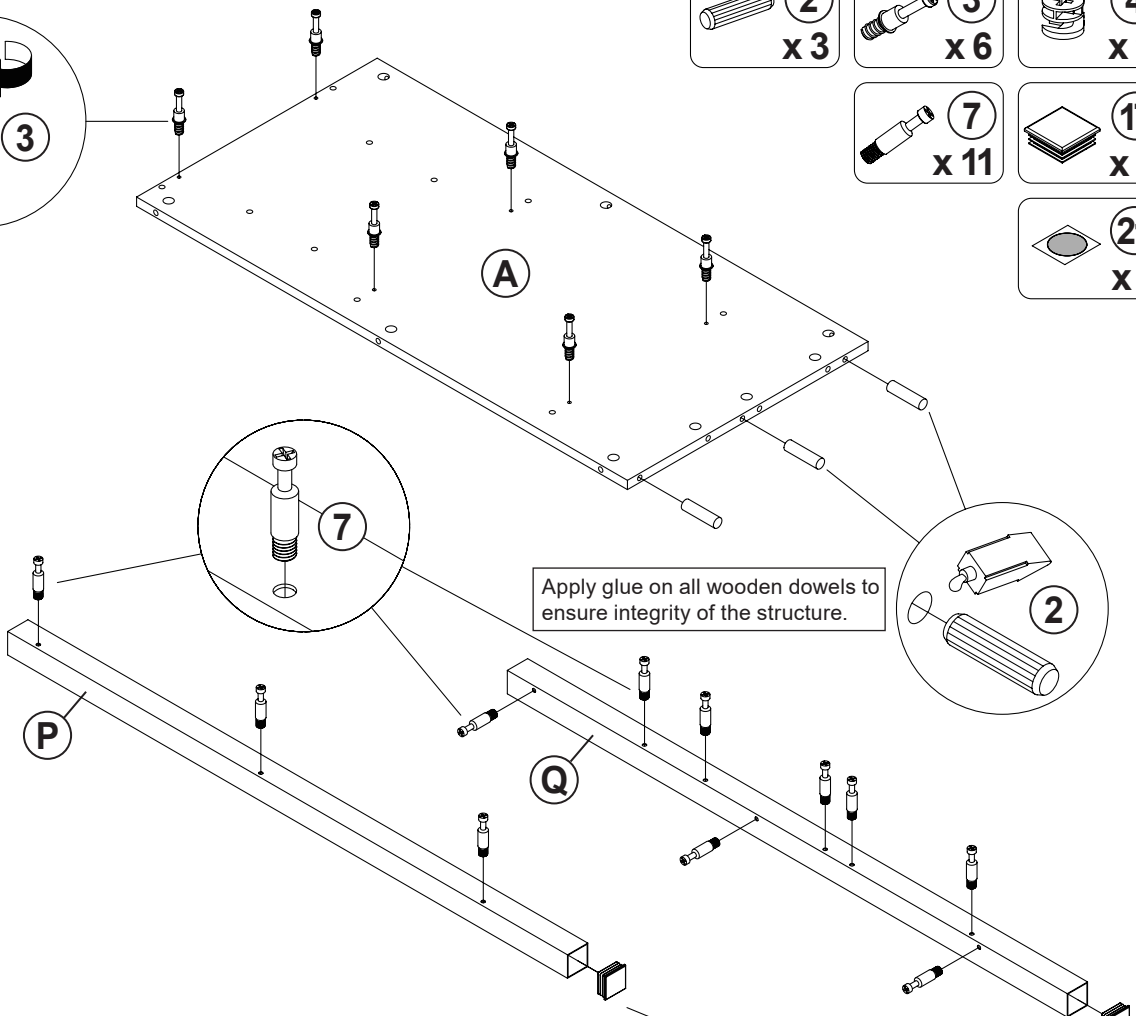
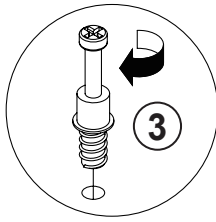
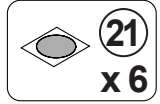
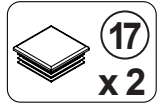
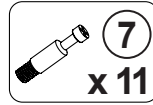
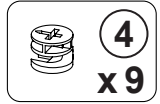
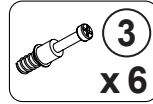
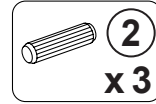

ITEM: 182105

COASTER
FINE FURNITURE

STEP 16

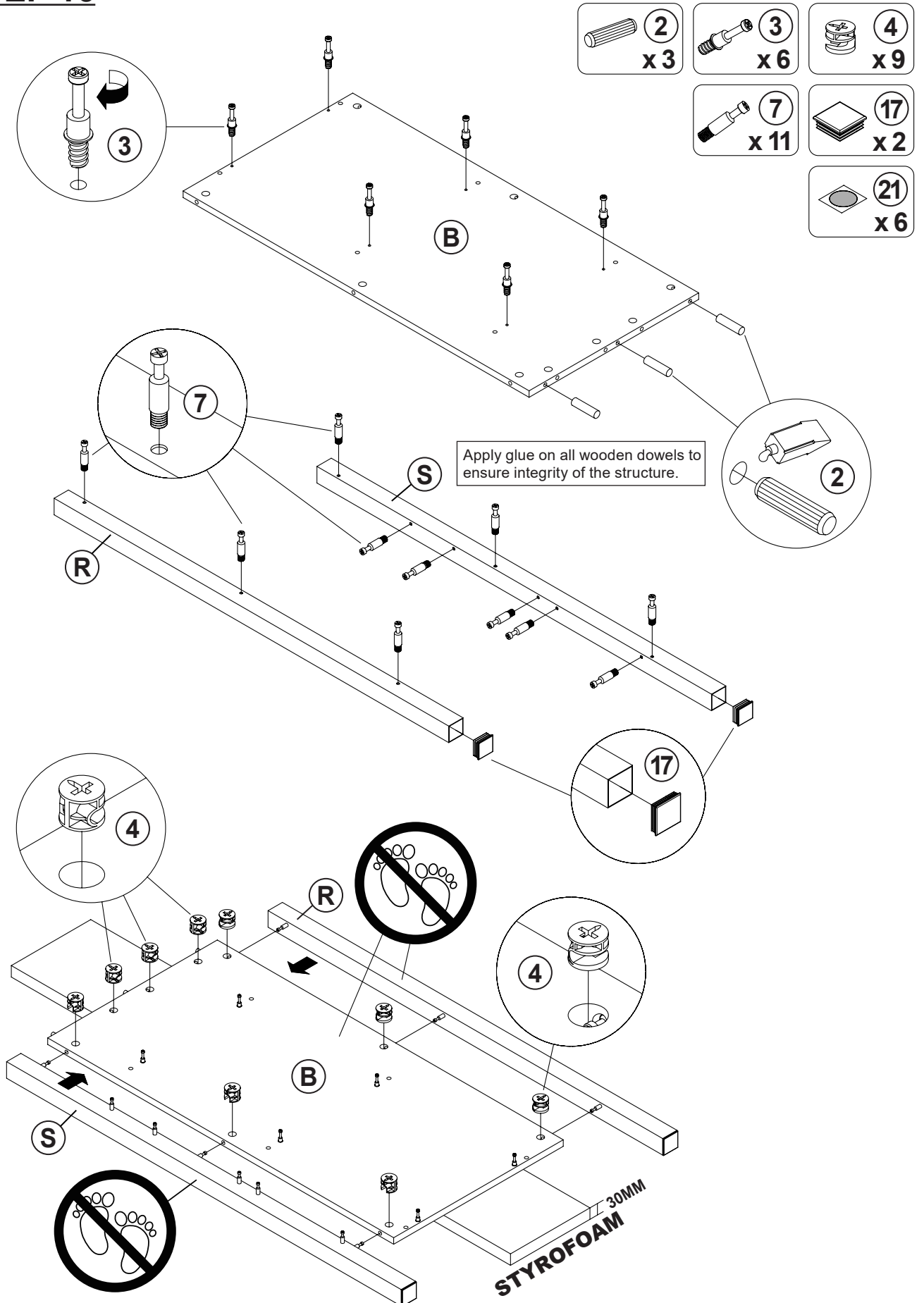

ITEM: **182105**

STEP 17

Please use the Styrofoam included in the packaging as a cushion during this step of the assembly.

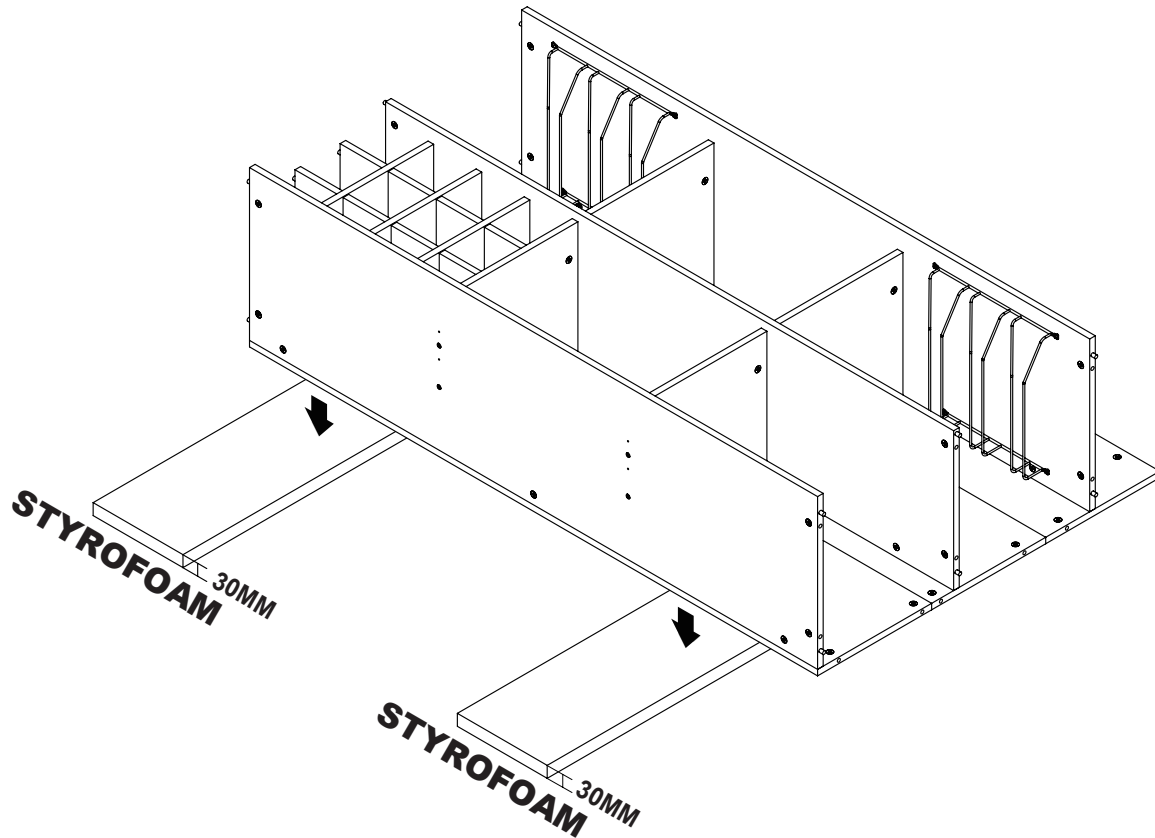

STEP 18

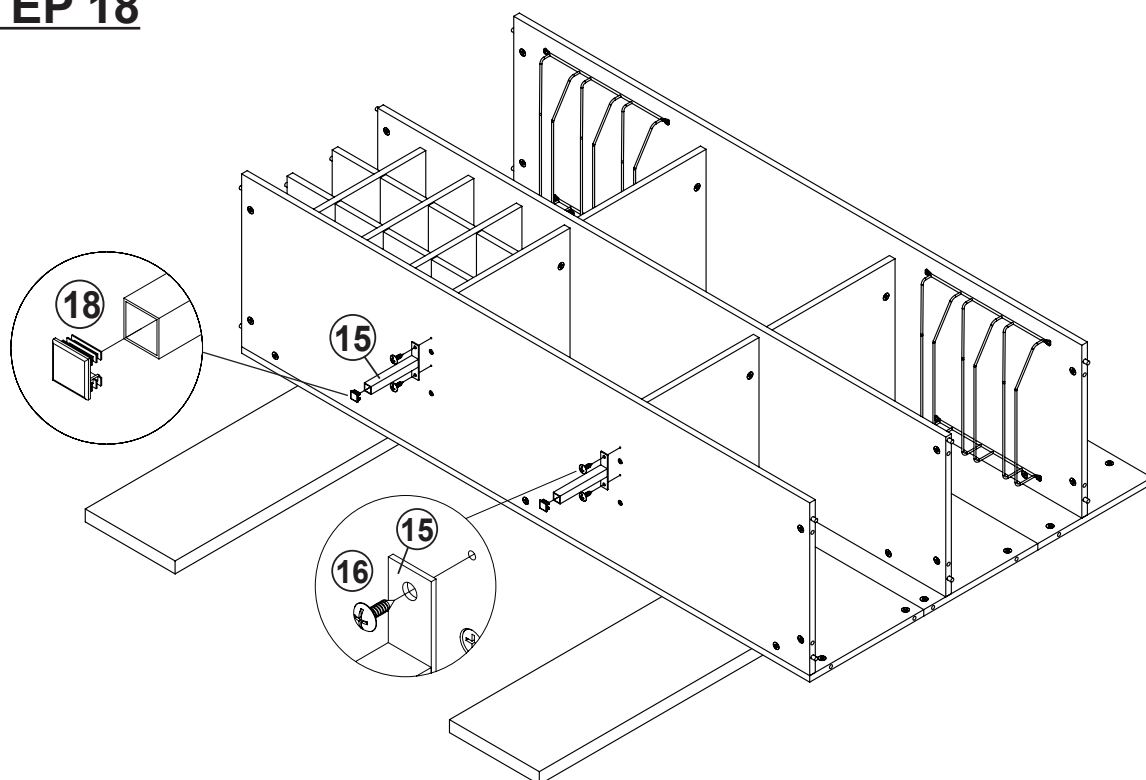

- 15 x 2
- 16 x 4
- 18 x 2

ITEM: **182105**

COASTER
FINE FURNITURE

STEP 19

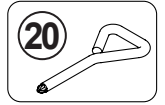
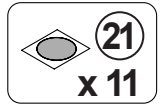
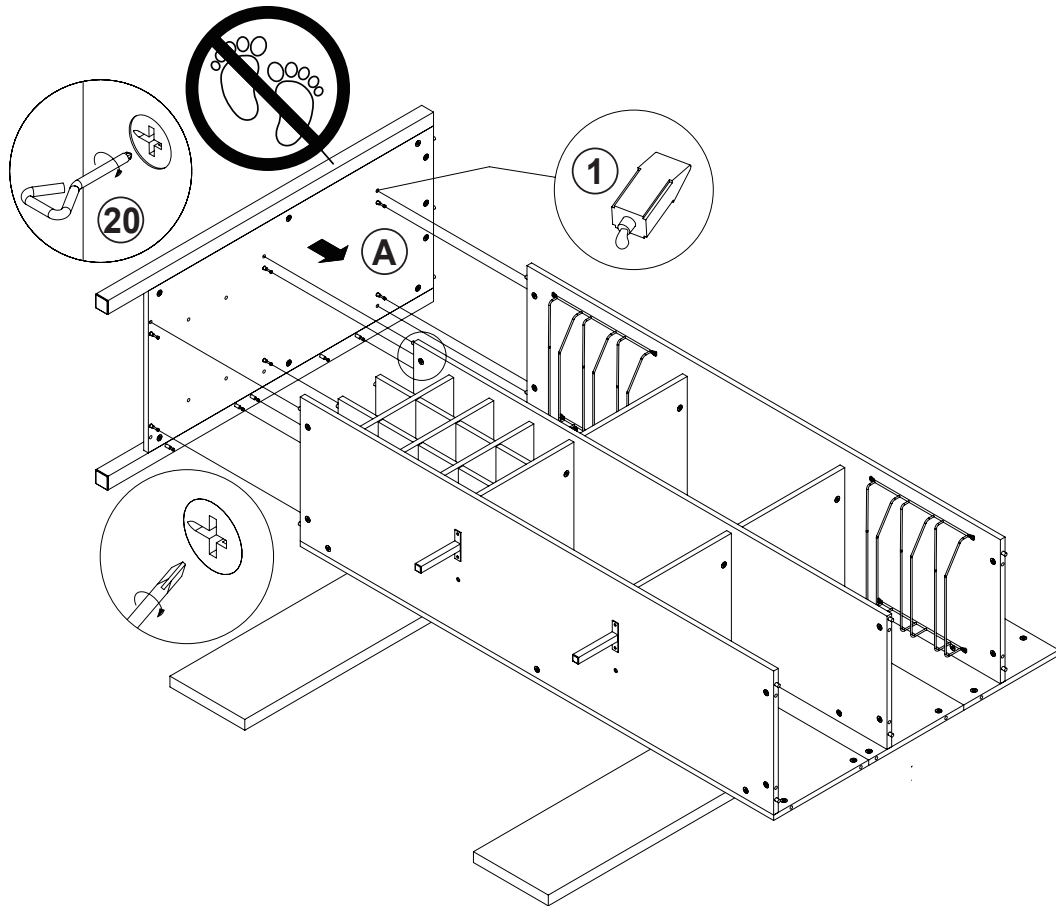

STEP 20

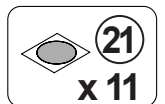
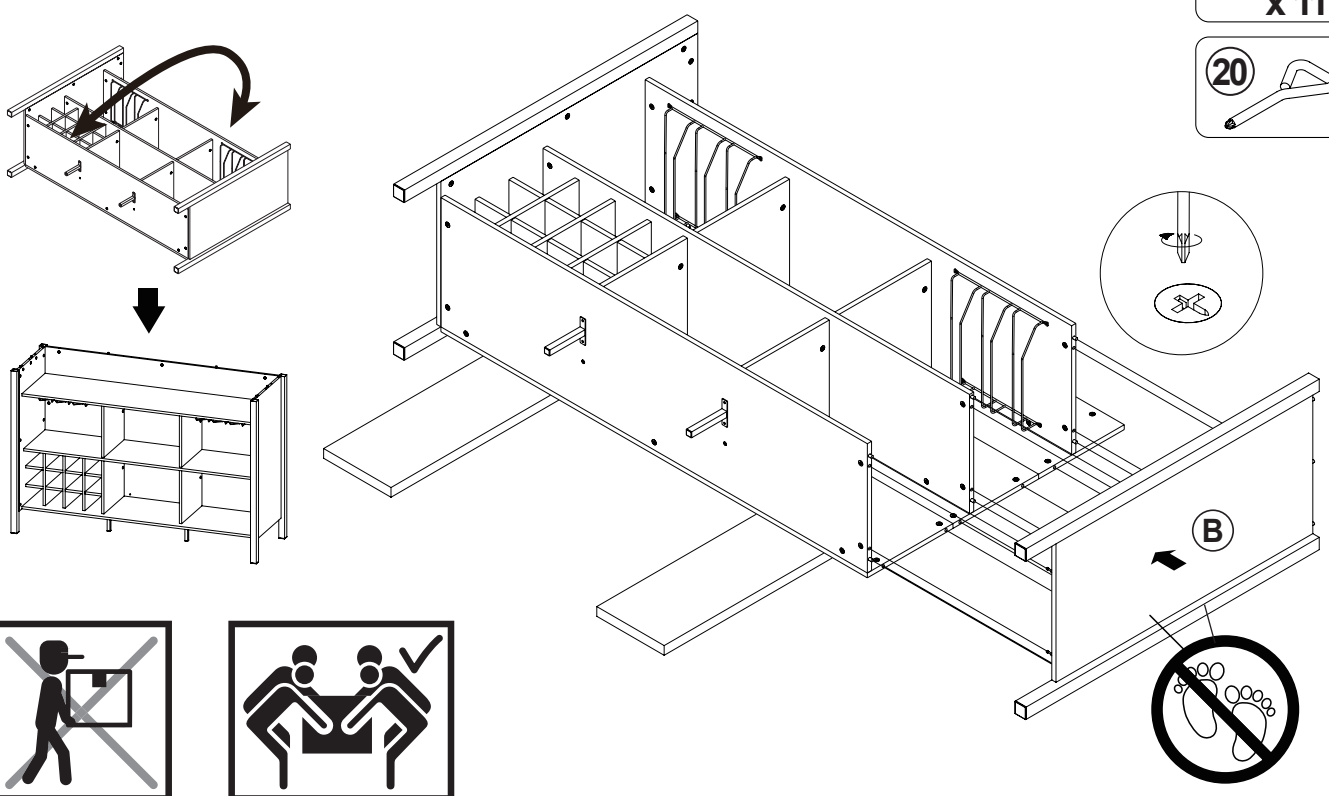

ITEM: **182105**

COASTER[®]

FINE FURNITURE

STEP 21

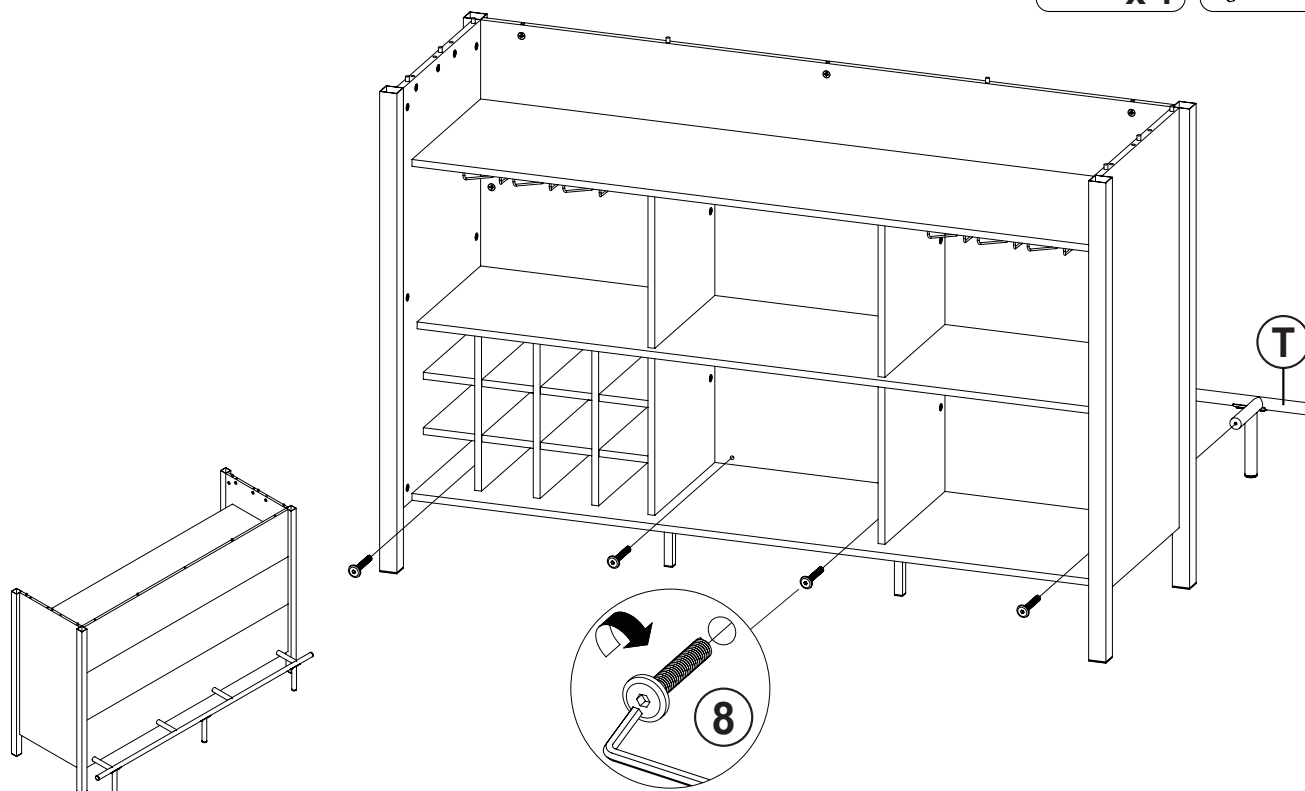

STEP 22

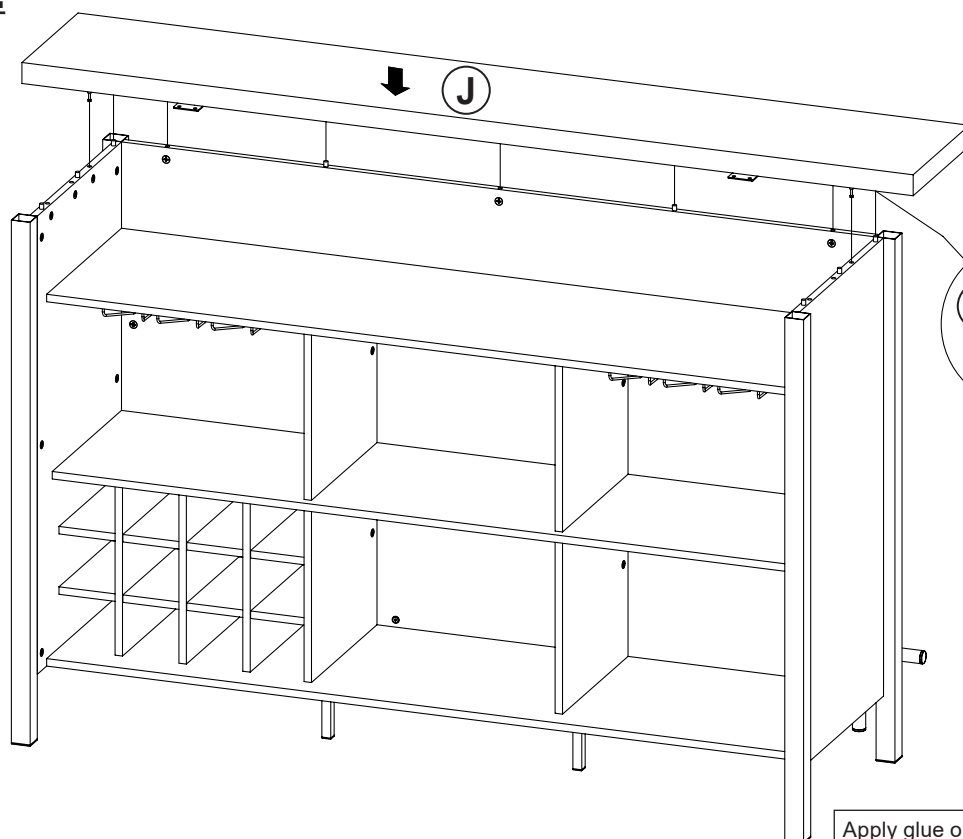
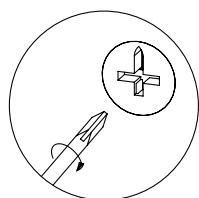
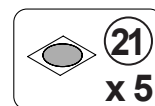

Apply glue on all wooden dowels to ensure integrity of the structure.

ITEM: **182105**

STEP 23

COASTER
FINE FURNITURE

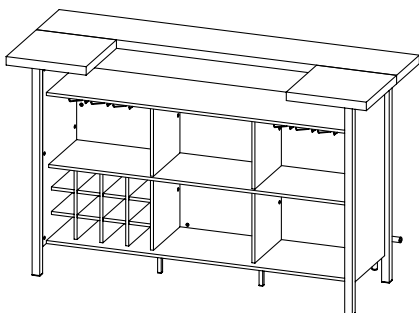
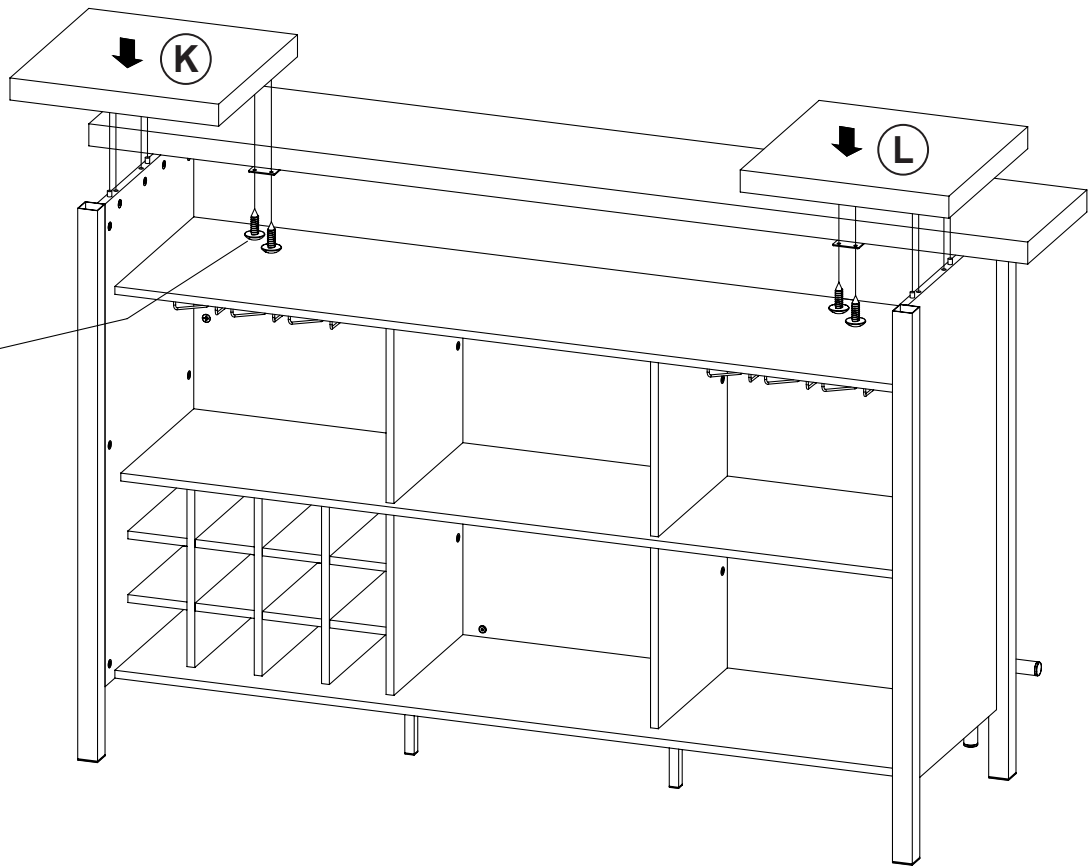
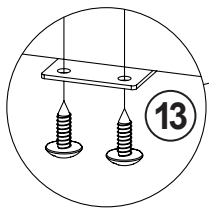
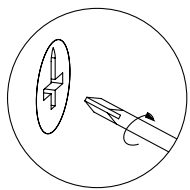

ITEM: 182105

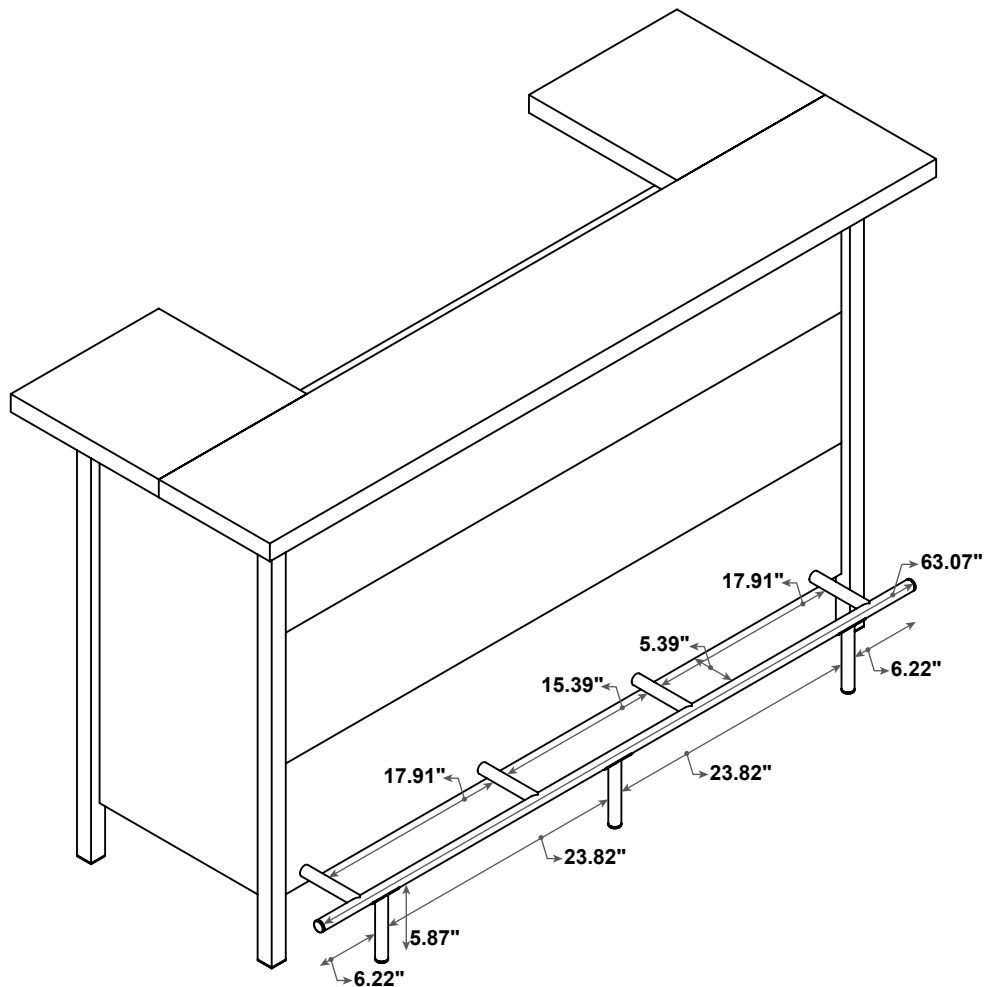
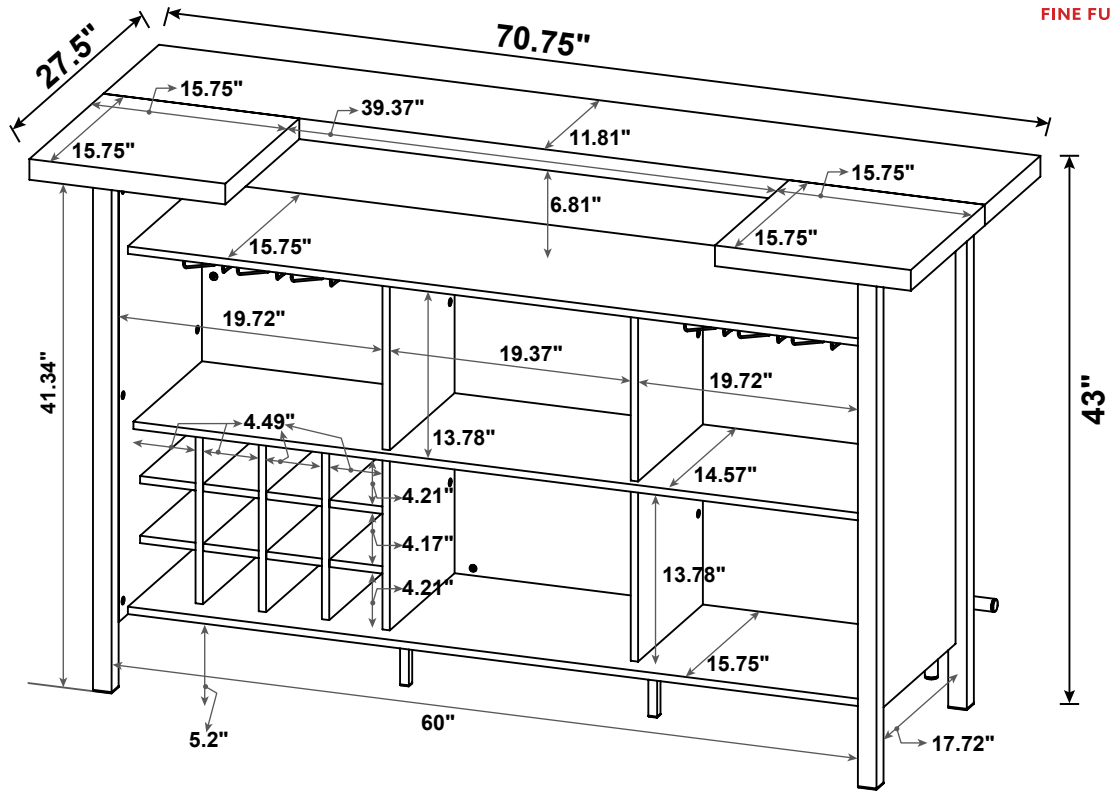

Note : Dimension tolerance $\pm 5\%$