

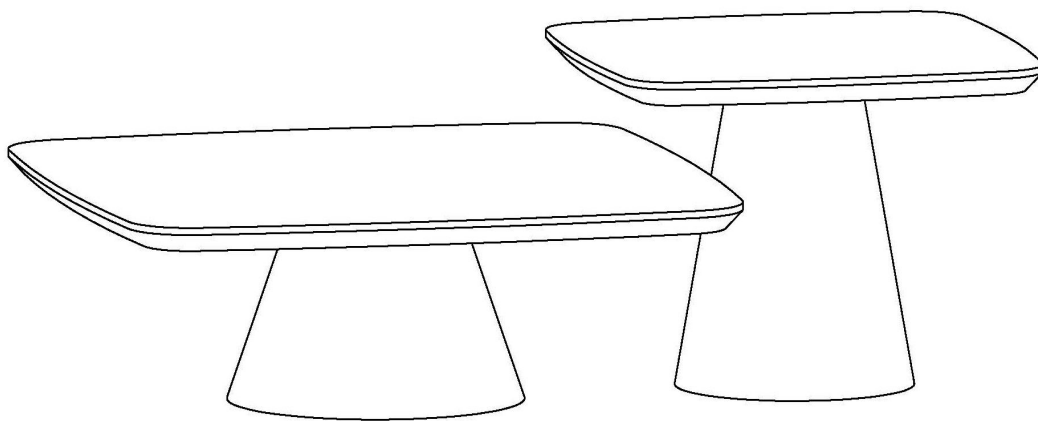

ASSEMBLY INSTRUCTIONS

COASTER FINE FURNITURE



Fine Furniture for every stage of life

710010
NESTING TABLE

REVISION 0: 08/14/2024

ITEM:710010



ASSEMBLY INSTRUCTIONS

ASSEMBLY TIPS:

1. Remove hardware from box and sort by size.
2. Please check to see that all hardware and parts are present prior to start of assembly.
3. Please follow attached instructions in the same sequence as numbered to assure fast & easy assembly.



WARNING

1. Don't attempt to repair or modify parts that are broken or defective. Please contact the store immediately.
2. This product is for home use only and not intend for commercial establishments.



ASSEMBLY TIME

20 MINUTES

PARTS IDENTIFICATION

B1 (BOX 1)

A BIG TABLE TOP

1PC



C SMALL TABLE TOP

1PC



B2 (BOX 2)

B BIG TABLE BASE

1PC

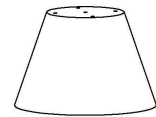

D SMALL TABLE BASE

1PC

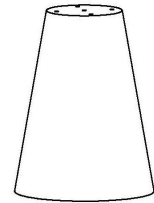

HARDWARE IDENTIFICATION

1 BOLT
1/4"x1"

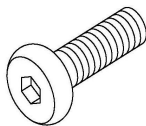

10PCS

2 SPRING WASHER
1/4"



10PCS

3 WASHER



10PCS

4 ALLEN KEY
1/4"



1PC

Hardware pack is located in 710010B2

ITEM:710010

ASSEMBLY INSTRUCTIONS



STEP 1

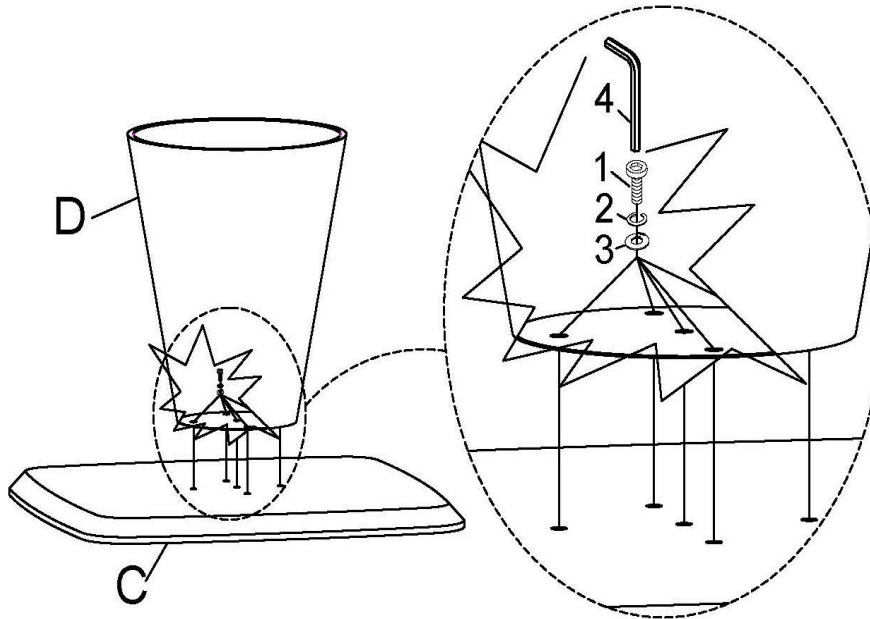

1		5 PCS
2		5 PCS
3		5 PCS
4		1 PC

STEP 2

COMPLETE

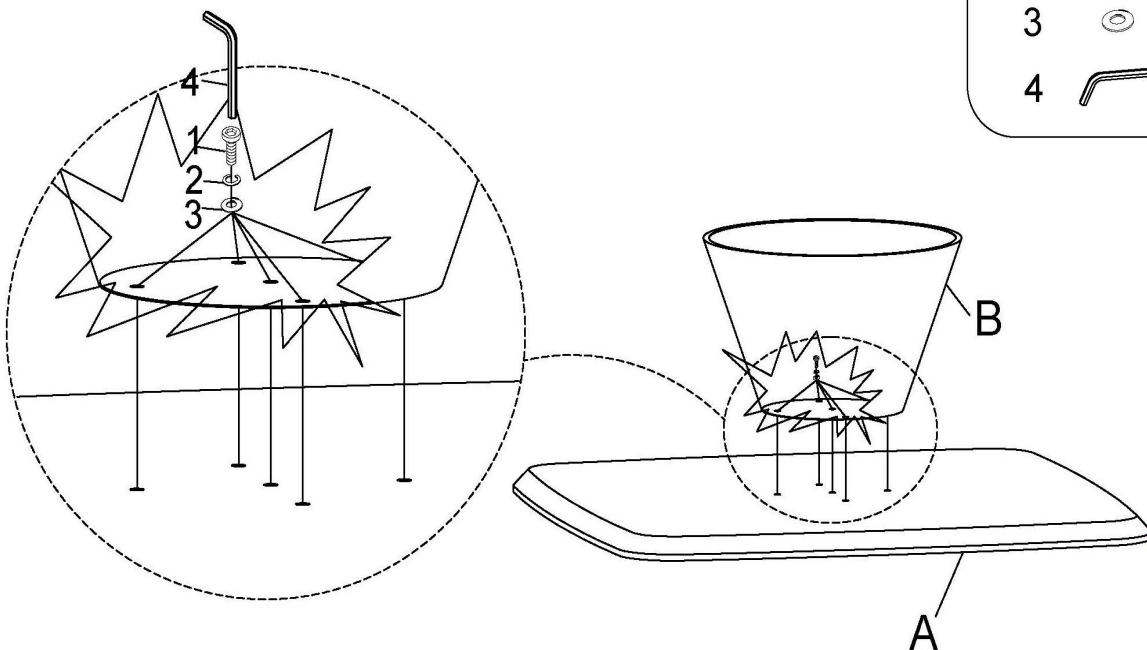

1		5 PCS
2		5 PCS
3		5 PCS
4		1 PC

ITEM:710010



ASSEMBLY INSTRUCTIONS

STEP 3

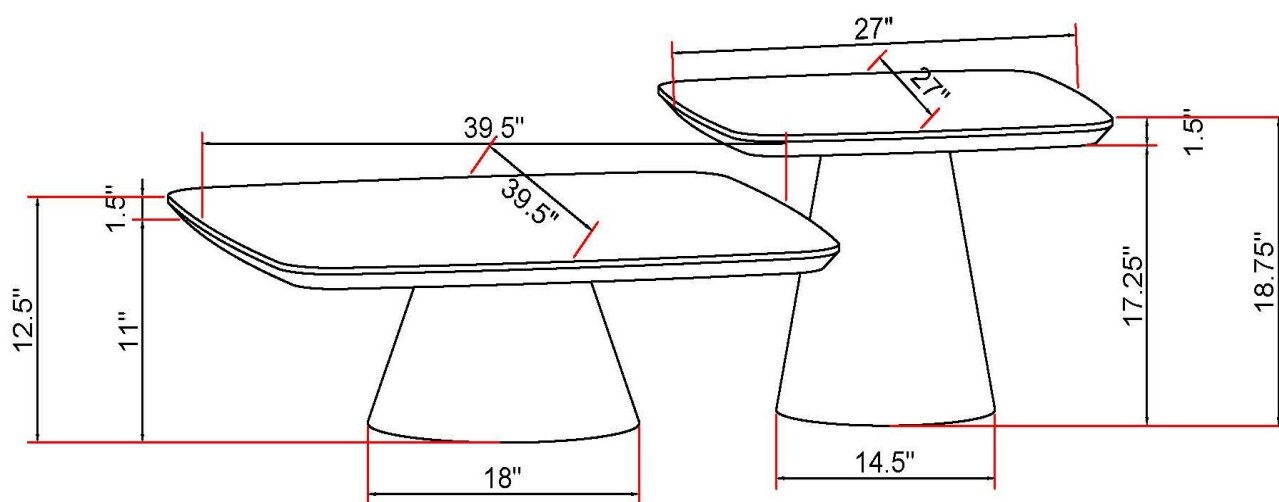

Note: Dimension tolerance $\pm 5\%$