

*ASSEMBLY INSTRUCTIONS
COASTER FINE FURNITURE*



Fine Furniture for every stage of life

182082
WINE CABINET

ITEM: 182082



ASSEMBLY INSTRUCTIONS

ASSEMBLY TIPS:

1. Remove hardware from box and sort by size.
2. Please check to see that all hardware and parts are present prior to start of assembly.
3. Please follow attached instructions in the same sequence as numbered to assure fast & easy assembly.



WARNING!

1. Don't attempt to repair or modify parts that are broken or defective. Please contact the store immediately.
2. This product is for home use only and not intended for commercial establishments.



ASSEMBLY TIME

90 MINUTES

PARTS IDENTIFICATION

A	LEFT SIDE PANEL		1 PC	G	LOWER BACK PANEL		2 PCS
B	RIGHT SIDE PANEL		1 PC	H	LEFT DOOR		1 PC
C	MIDDLE DIVIDER PANEL		1 PC	I	RIGHT DOOR		1 PC
D	BOTTOM PANEL		1 PC	J	UPPER LEFT SIDE PANEL		1 PC
E	LOWER CROSS PANEL		2 PCS	K	UPPER RIGHT SIDE PANEL		1 PC
F	TOP PANEL		1 PC	L	UPPER DIVIDER PANEL		1 PC

NOTE:

Phillips head screw driver is required in the assembly process; however, manufacturer does not provide this item.

ITEM: 182082

M UPPER SMALL
DIVIDER PANEL

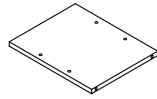

2 PCS

N UPPER
CROSS PANEL

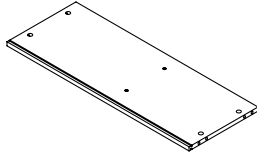

1 PC

O UPPER SMALL
CROSS PANEL

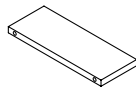

6 PCS

P UPPER SMALL
TOP PANEL

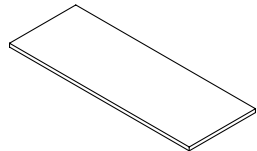

1 PC

Q MIDDLE
BACK PANEL

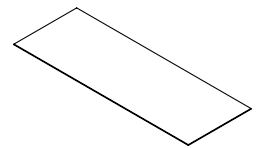

1 PC

R UPPER
BACK PANEL

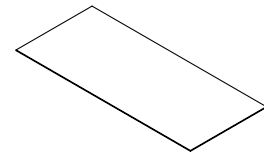

1 PC

S LEG FRAME

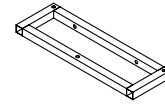

2 PCS

T UPPER
CROSSBAR

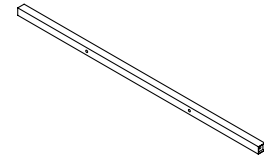

2 PCS

U LOWER
CROSSBAR

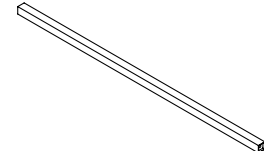

1 PC

V GLASS HOLDER

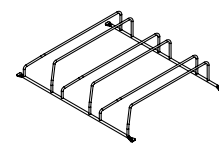









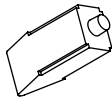

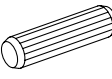
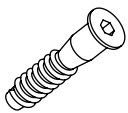
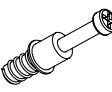
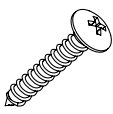

1 PC

NOTE:

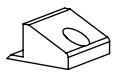
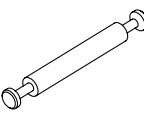
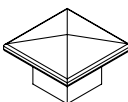
Phillips head screw driver is required in the assembly process; however, manufacturer does not provide this item.

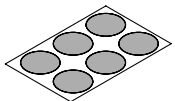
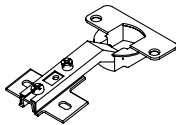
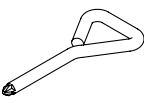
HARDWARE IDENTIFICATION

Z							
NO	DESCRIPTION	FIGURE	Q'TY	NO	DESCRIPTION	FIGURE	Q'TY
1	GLUE 40g		1 PC	12	BOLT M6x43mm BLK		6 PCS
2	WOODEN DOWEL Ø8x30mm		48 PCS	13	BOLT Ø7x32mm BLK		4 PCS
3	CAM BOLT Ø7x35.5mm SR		22 PCS	14	SCREW Ø5x35mm BLK		4 PCS
4	CAM LOCK Ø15x12mm SR		26 PCS	15	FLOOR PROTECTOR 20x20mm		4 PCS
5	SCREW Ø4.5x42mm SR		8 PCS	16	ALLEN WRENCH 4mm SR		1 PC
6	WOODEN DOWEL Ø8x50mm		10 PCS	17	FIXER		6 PCS
7	CAM BOLT Ø7x63mm SR		2 PCS	18	FIXER SCREW Ø3x19mm SR		6 PCS
8	HANDLE BLK		2 PCS	19	SCREW Ø4x18mm SR		4 PCS
9	HANDLE BOLT BLK		2 PCS	20	STICKER Ø20mm		5 PCS
10	HINGE Ø35mm SR		4 PCS	21	SCREW DRIVER		1 PC
11	HINGE SCREW Ø4x15mm SR		16 PCS				

Z10 not included in blister packaging.

NOTE:

Phillips head screw driver is required in the assembly process; however, manufacturer does not provide this item.

ITEM: **182082**

COASTER[®]

FINE FURNITURE

STEP 1

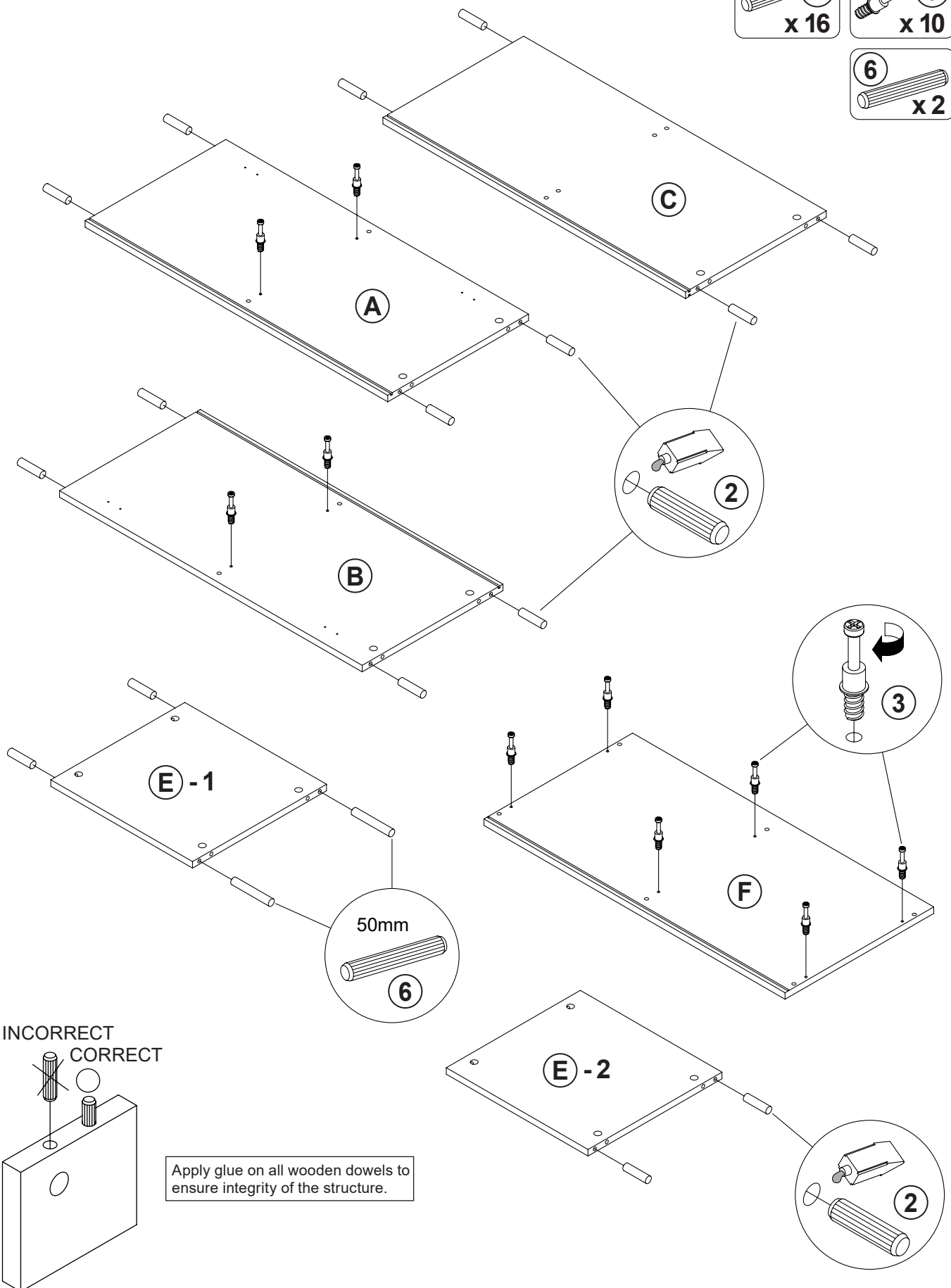
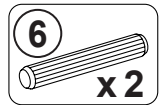
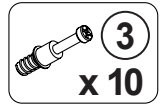
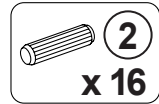

INCORRECT
CORRECT

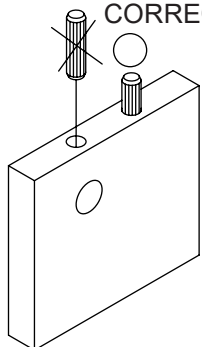

Apply glue on all wooden dowels to ensure integrity of the structure.

ITEM: 182082

COASTER
FINE FURNITURE

STEP 2

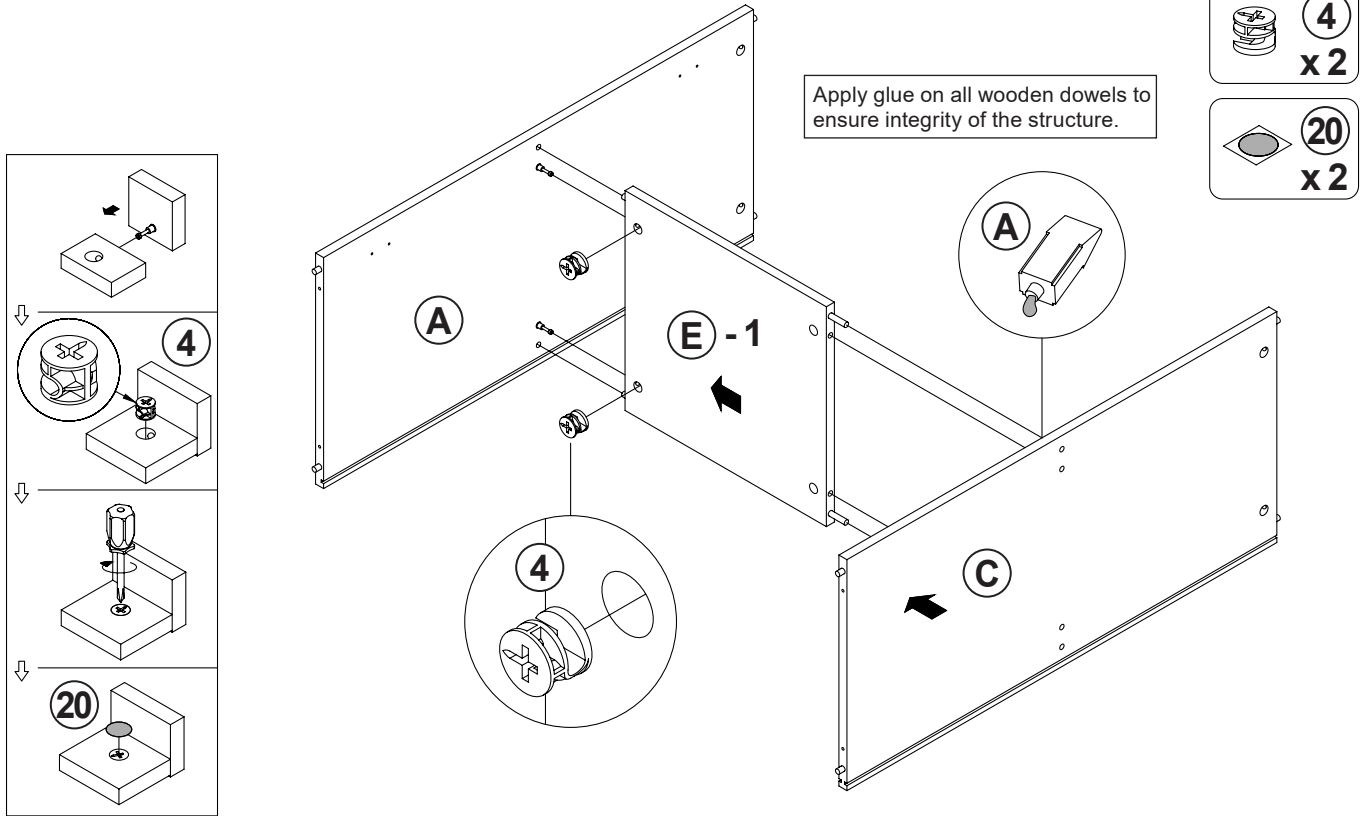

STEP 3

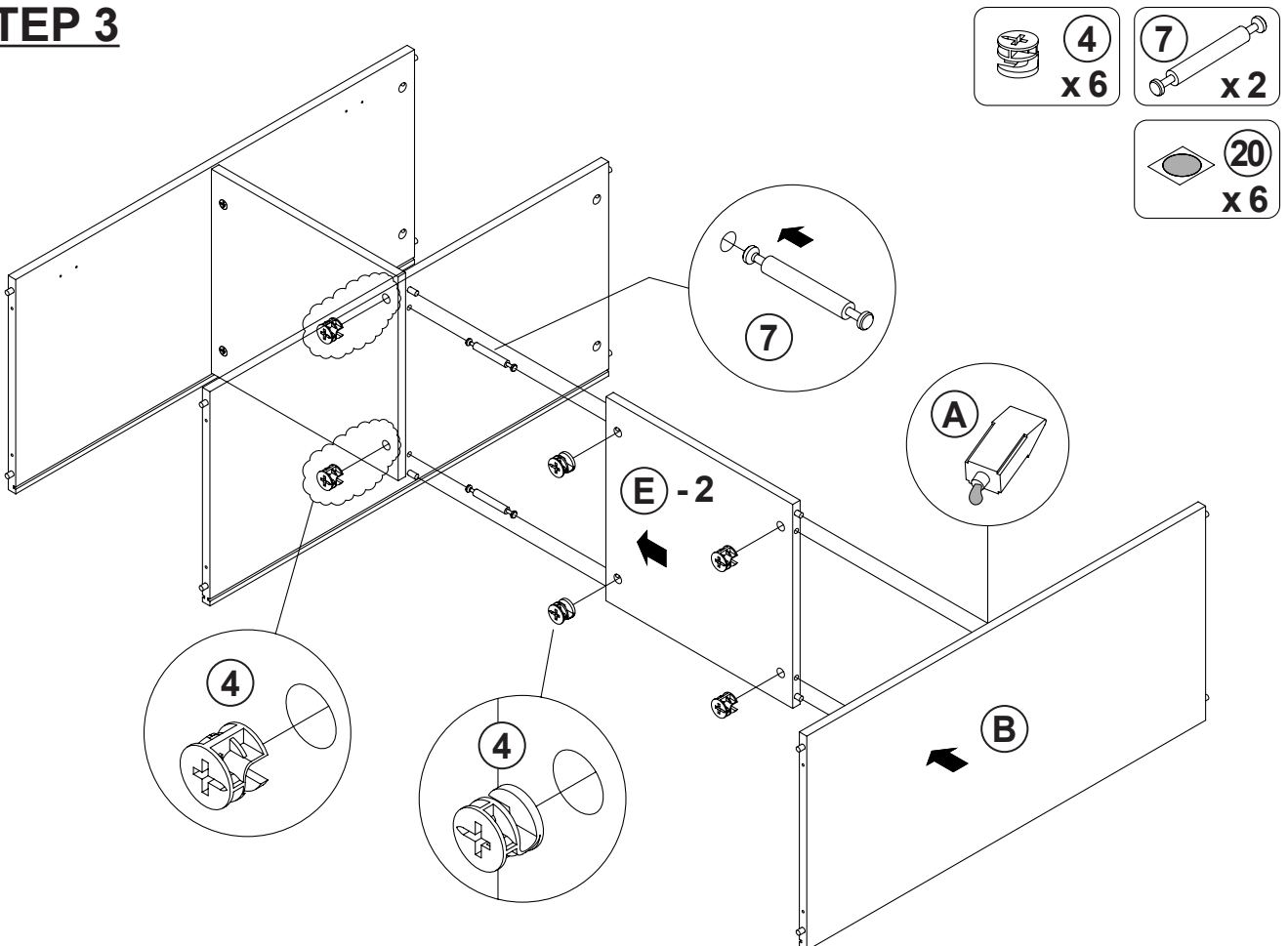

ITEM: **182082**

COASTER
FINE FURNITURE

STEP 4

Apply glue on all wooden dowels to ensure integrity of the structure.

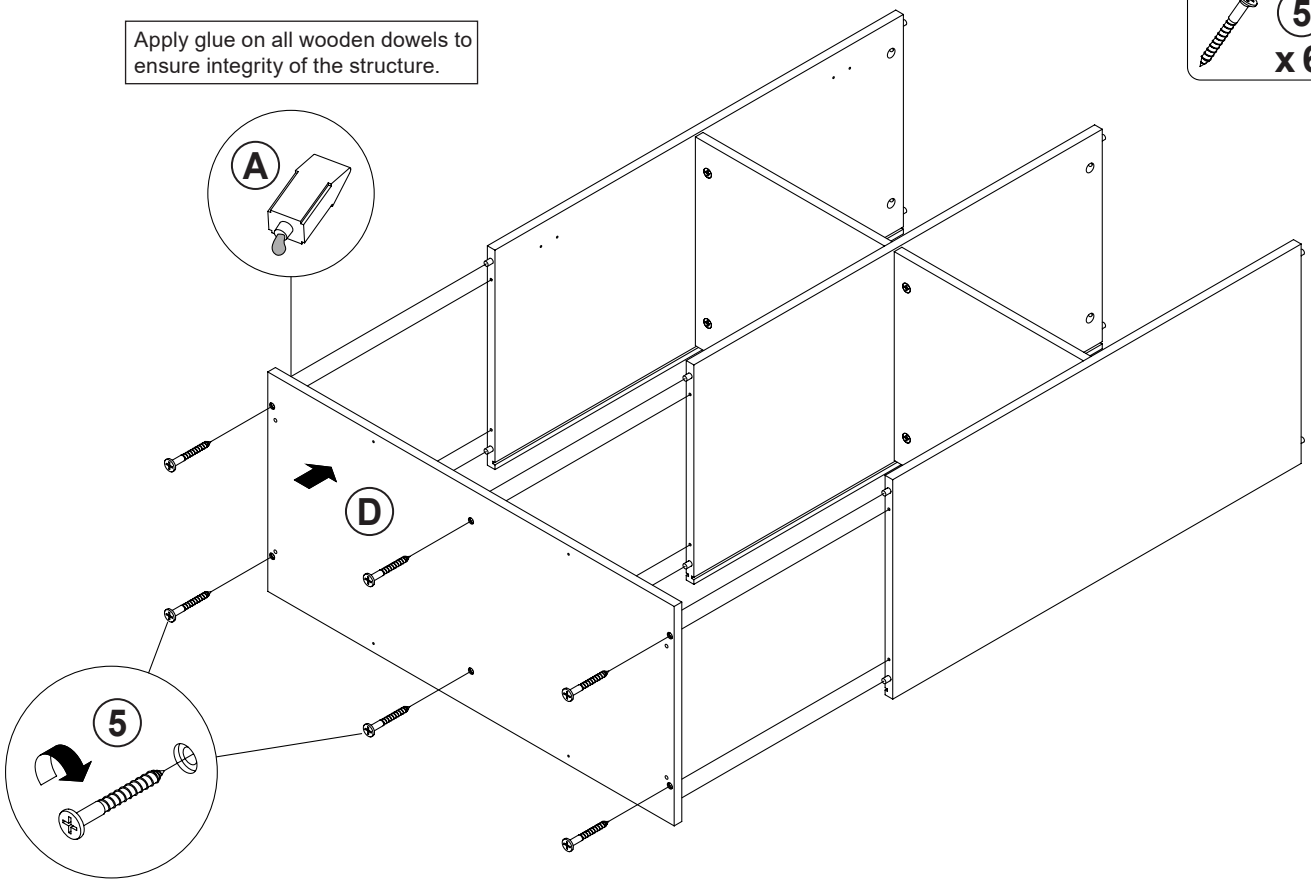
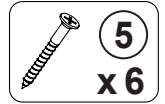

STEP 5

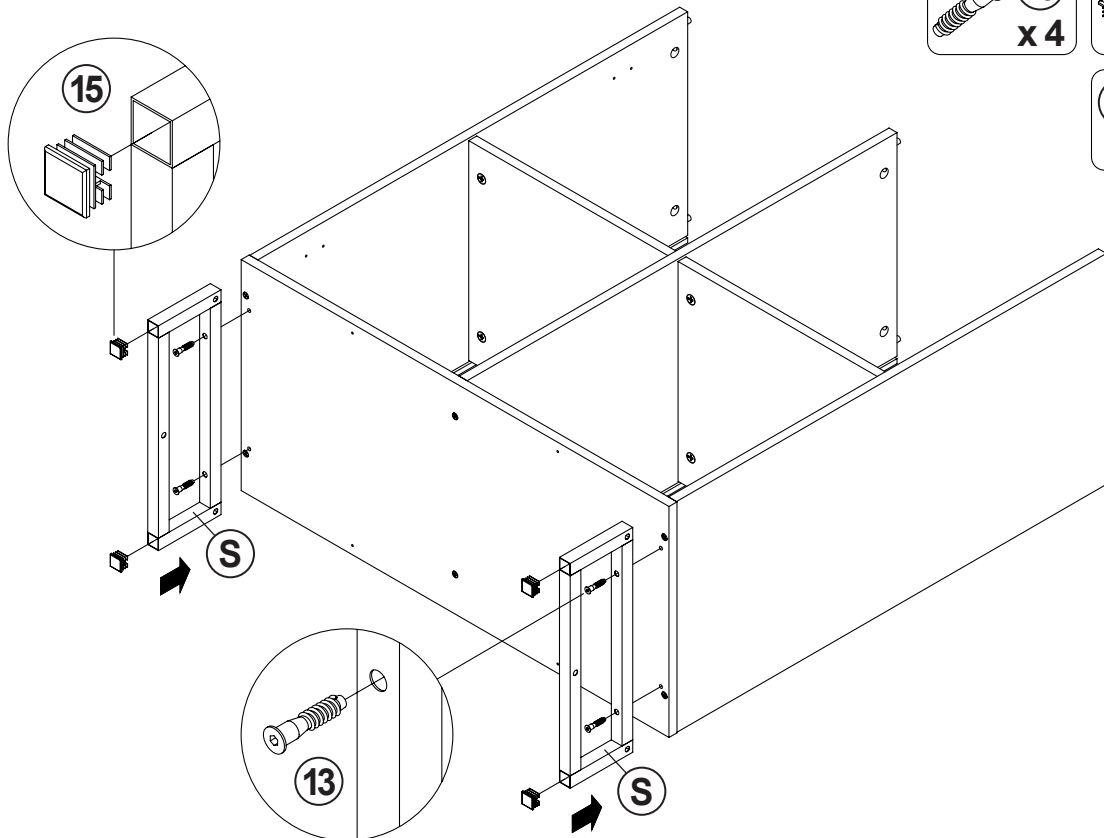
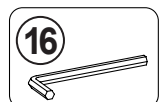
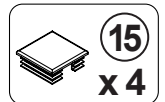
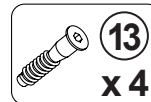

ITEM: **182082**

STEP 6

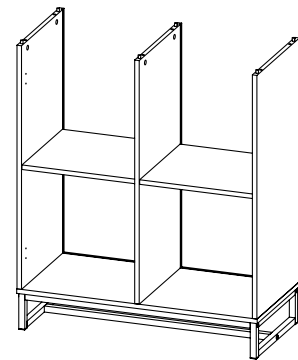
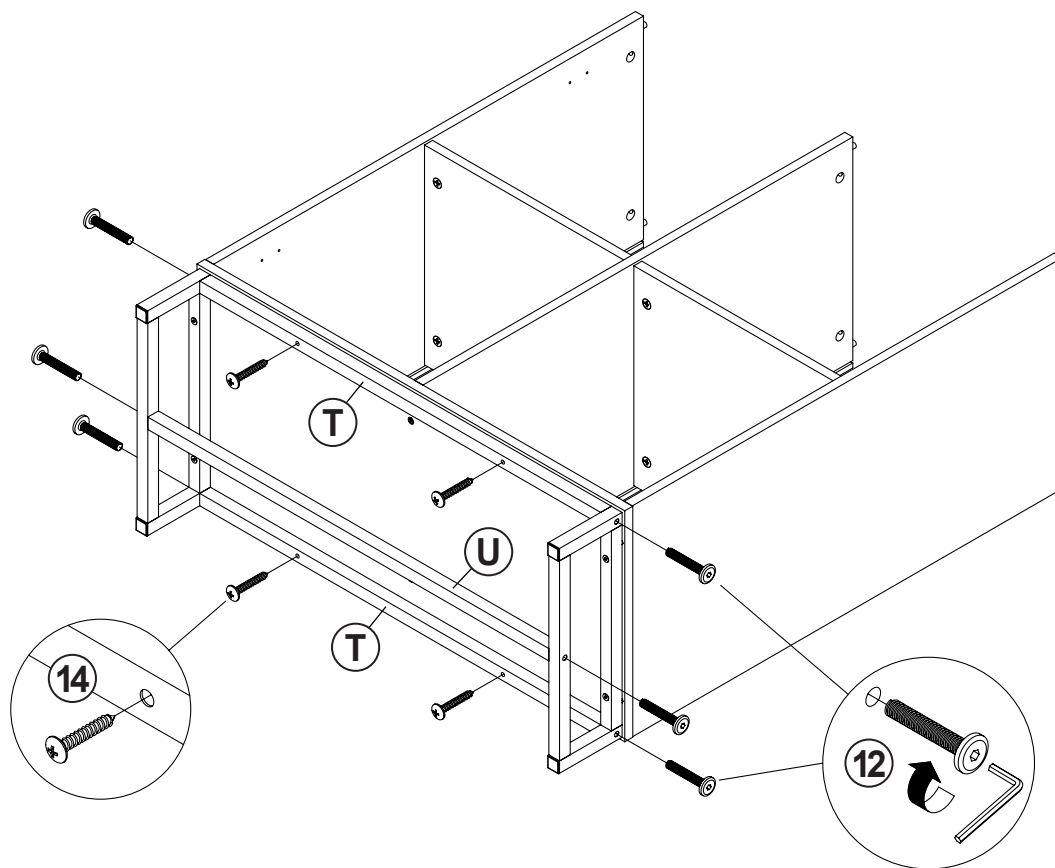
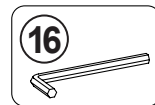
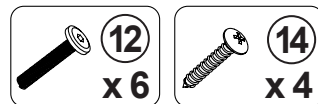

STEP 7

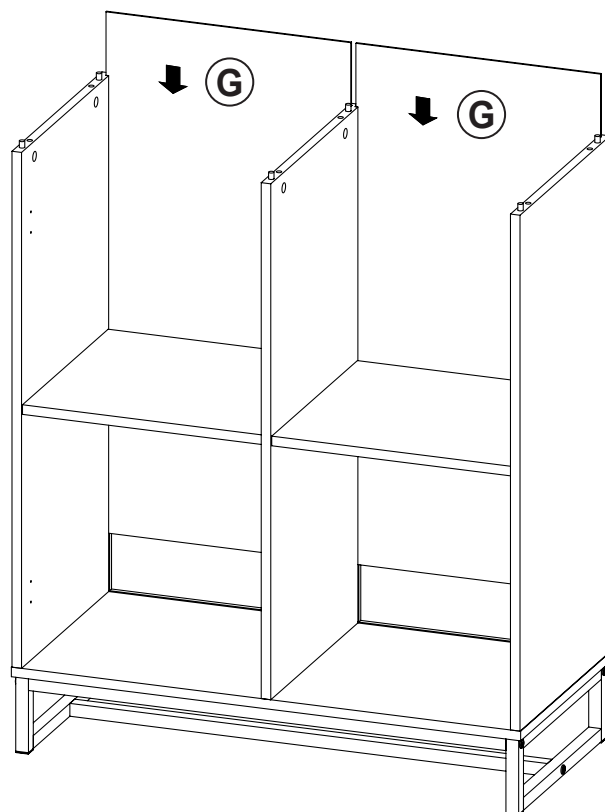

ITEM: 182082

STEP 8

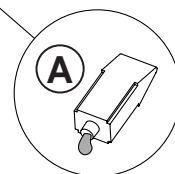
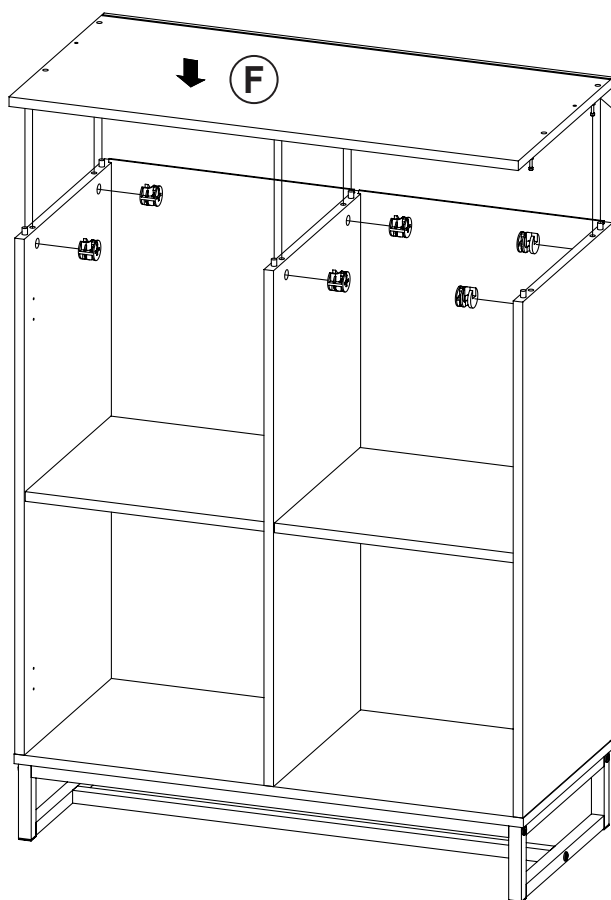
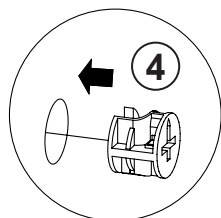

Apply glue on all wooden dowels to ensure integrity of the structure.

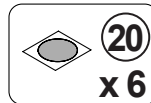
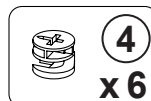

STEP 9

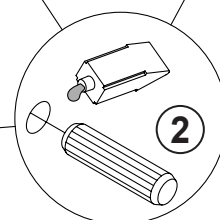
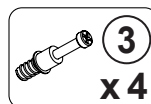
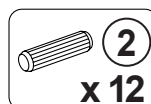
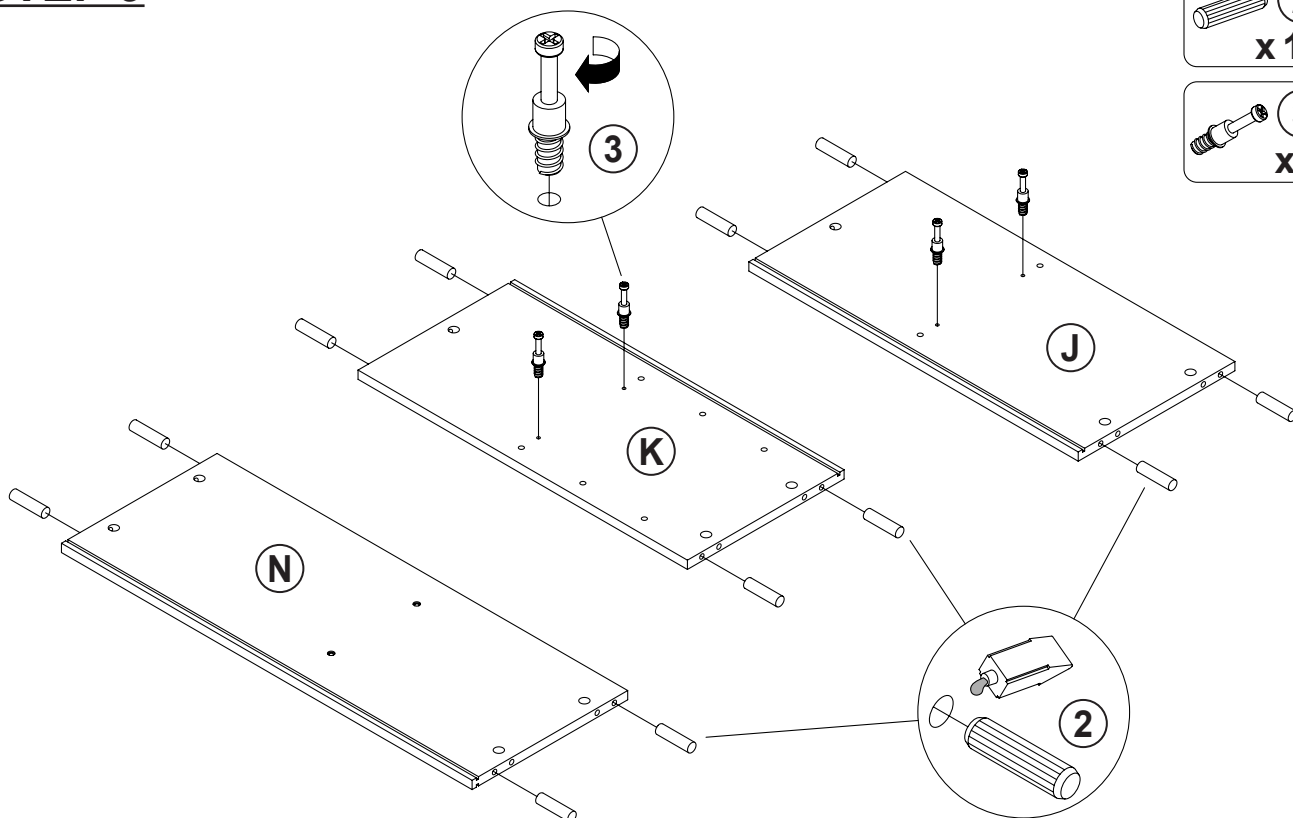

ITEM: **182082**

COASTER
FINE FURNITURE

STEP 10

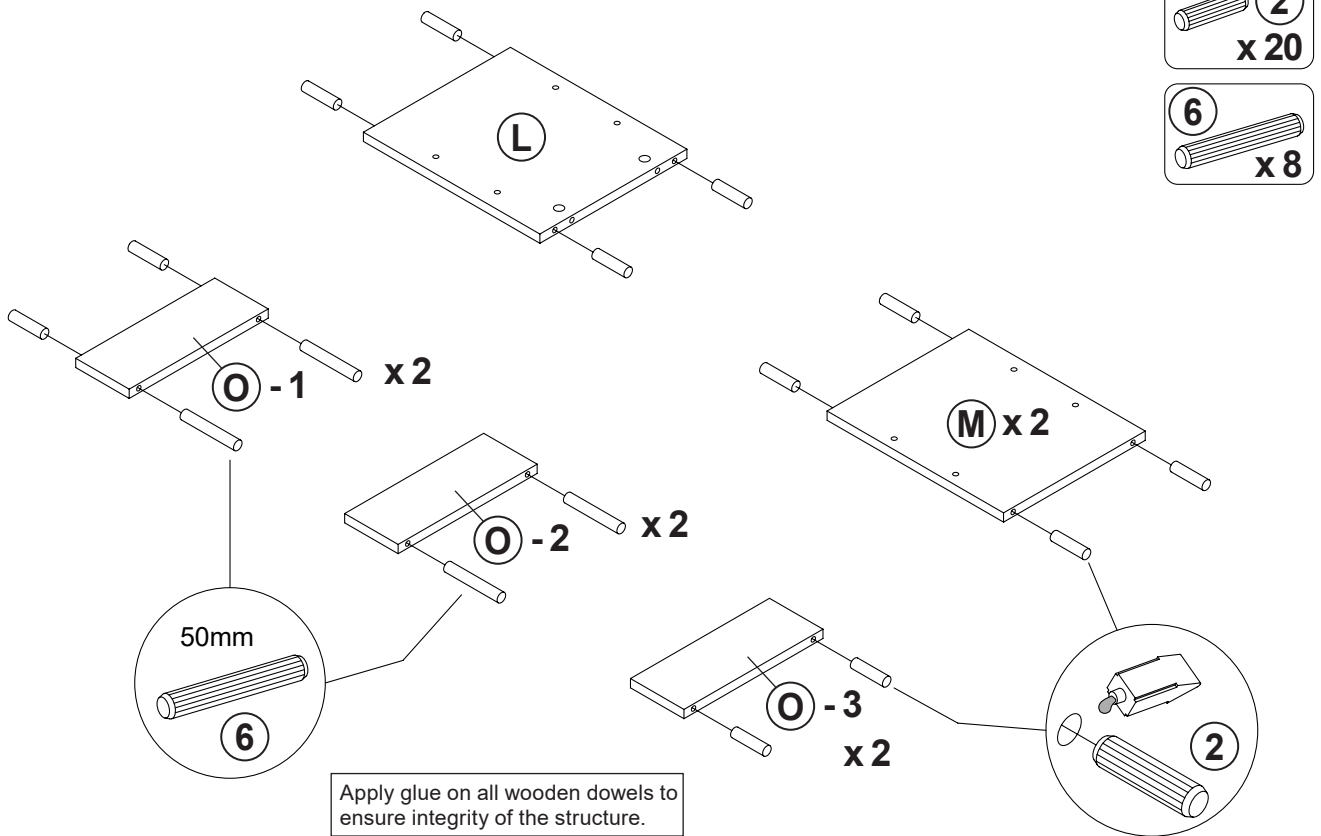

STEP 11

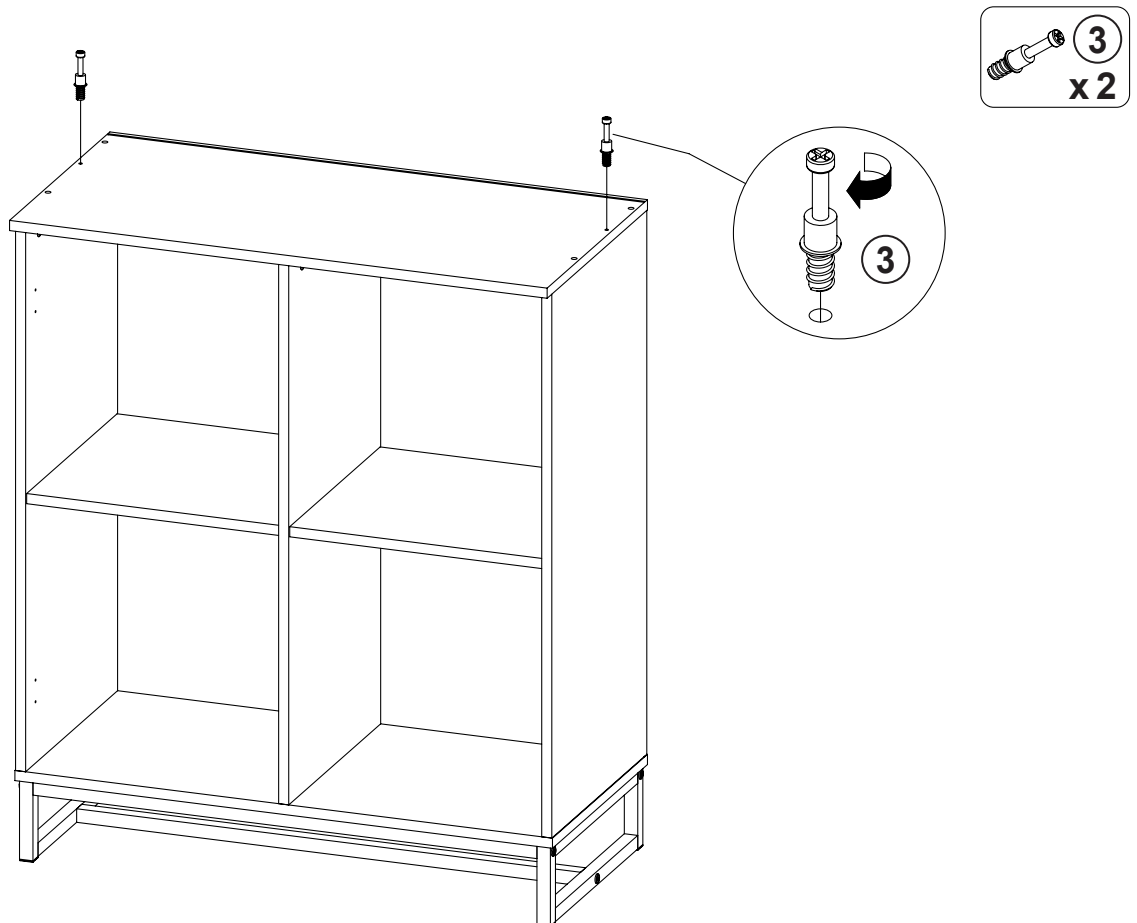

ITEM: **182082**

COASTER[®]

FINE FURNITURE

STEP 12

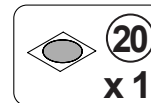
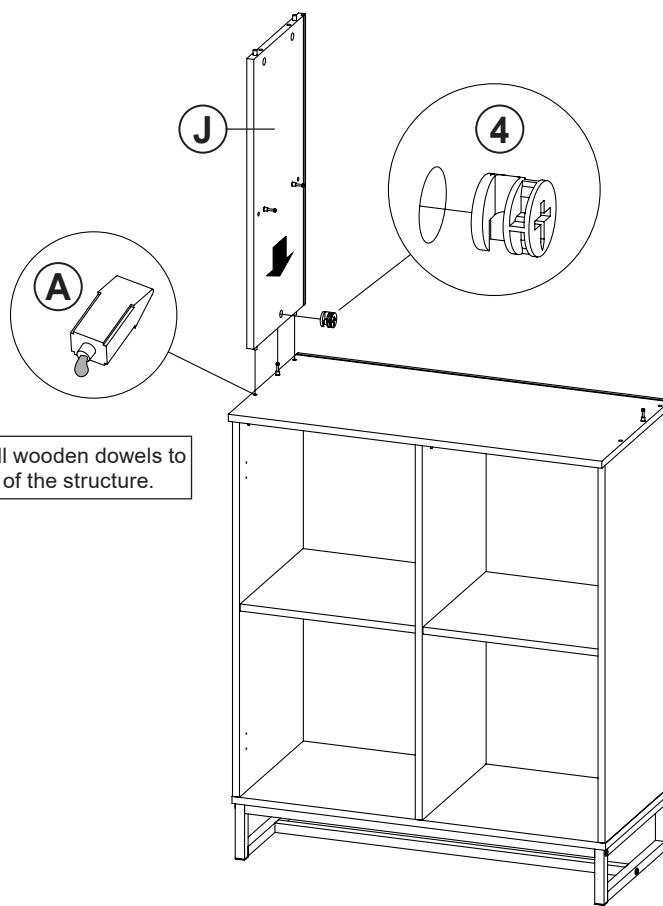

Apply glue on all wooden dowels to ensure integrity of the structure.

STEP 13

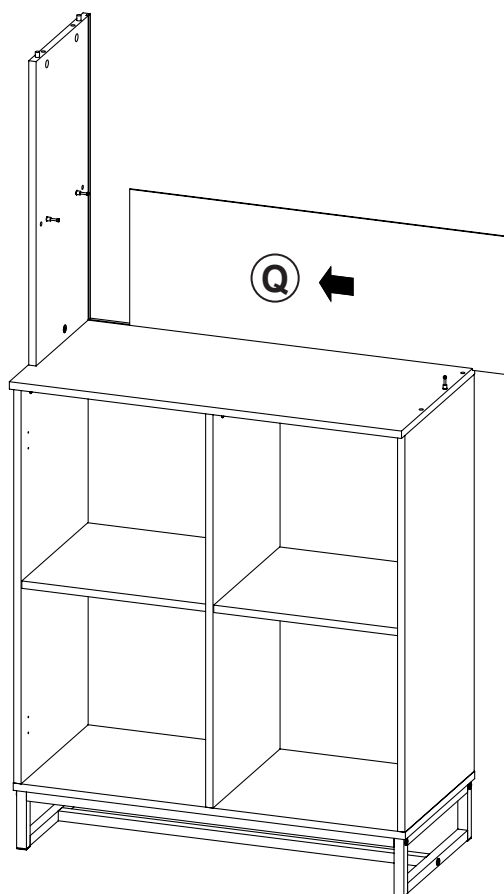

ITEM: **182082**

STEP 14

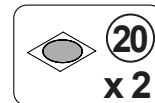
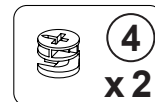
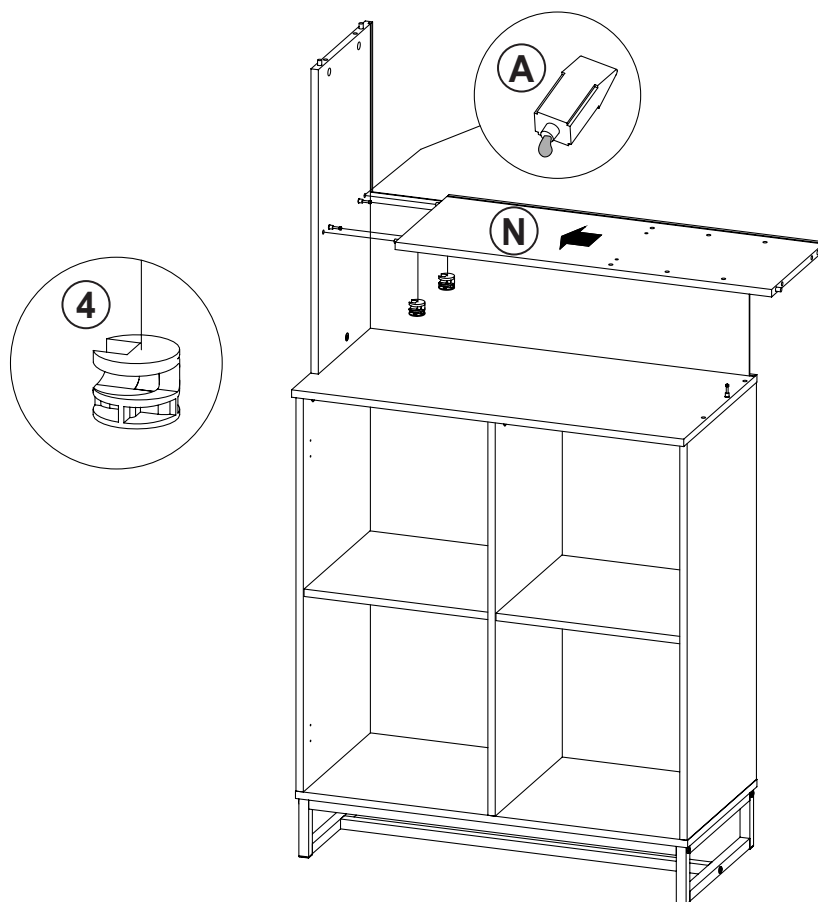

STEP 15

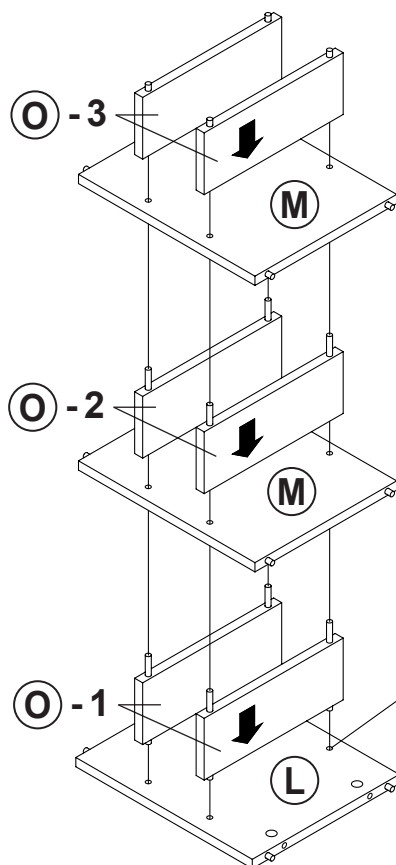

Apply glue on all wooden dowels to ensure integrity of the structure.

ITEM: **182082**

STEP 16

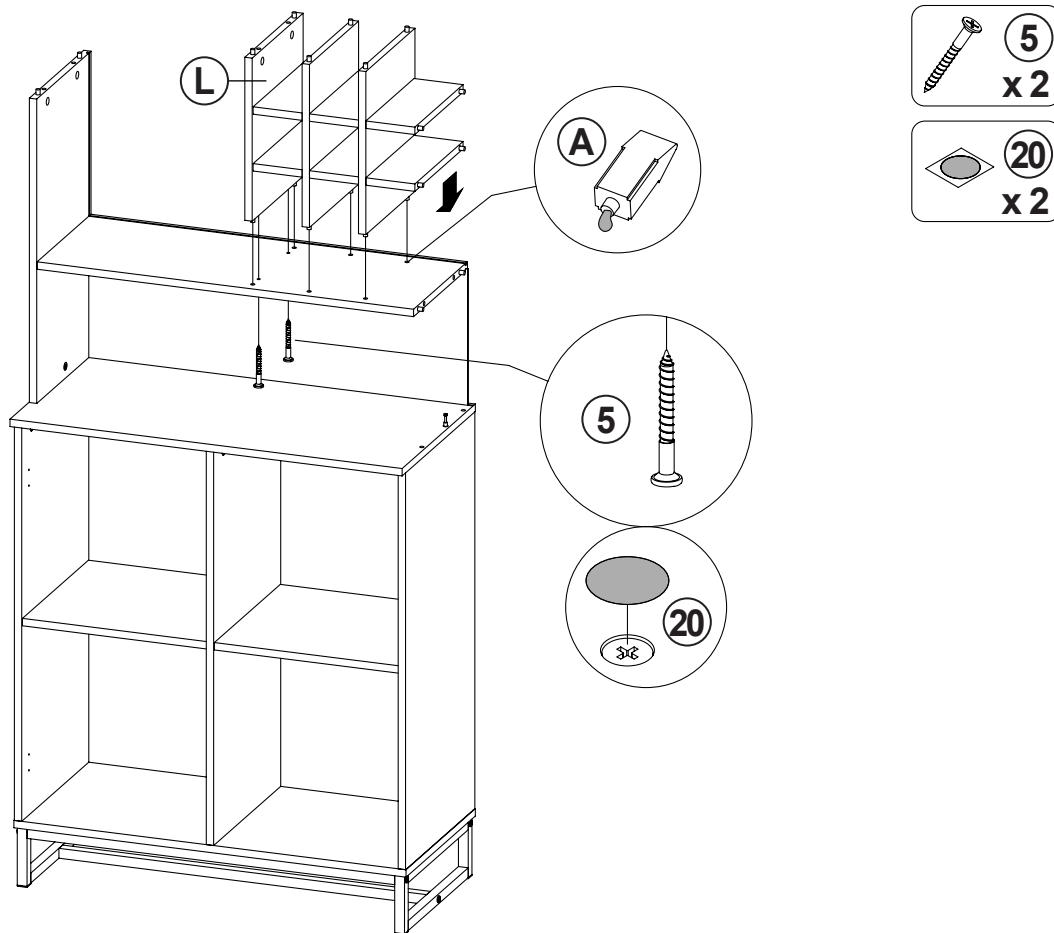

STEP 17

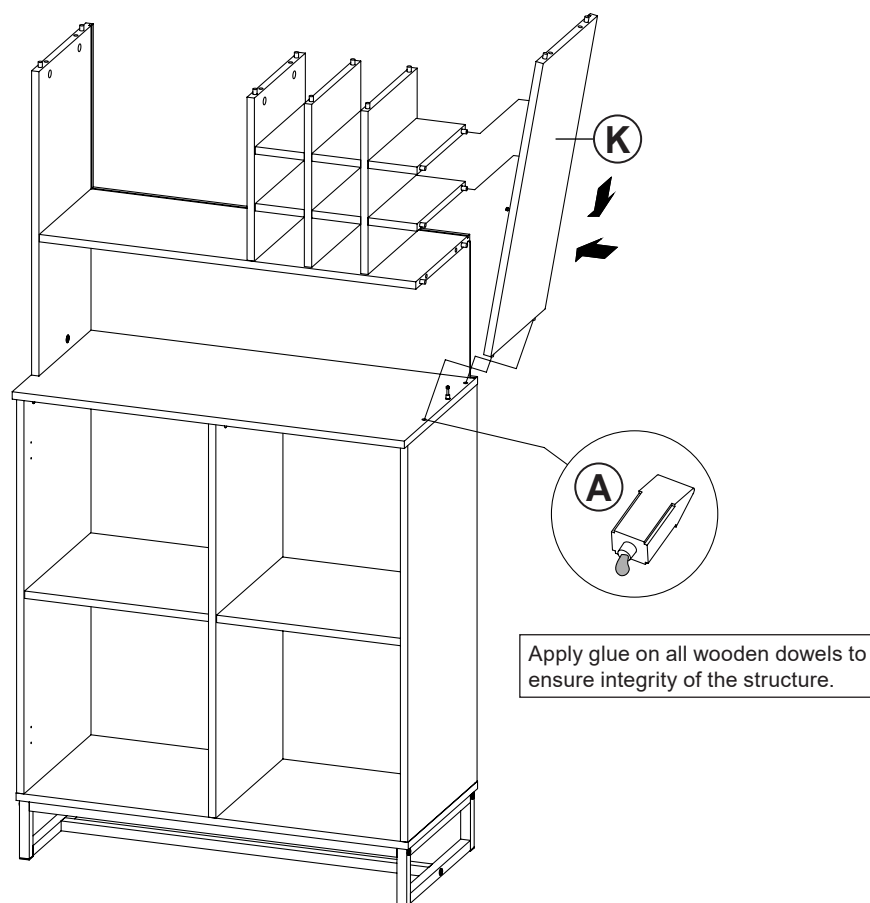

ITEM: **182082**

COASTER[®]

FINE FURNITURE

STEP 18

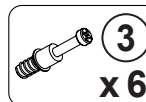
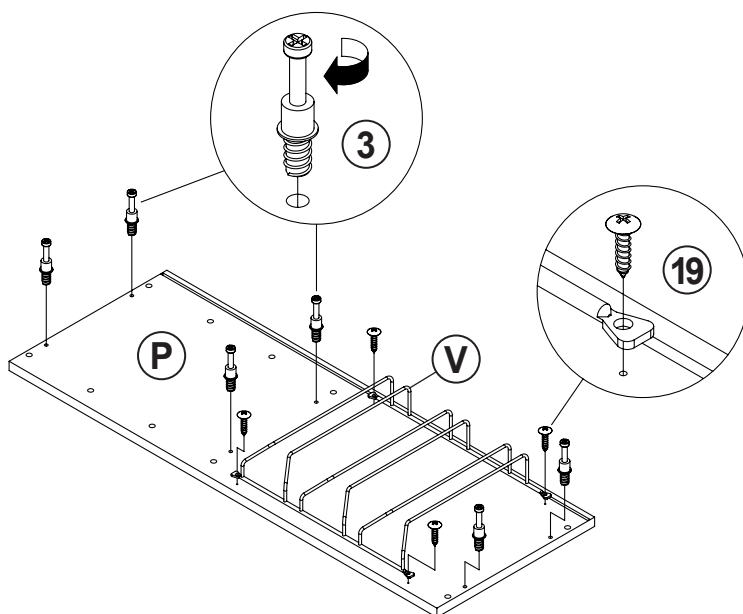

STEP 19

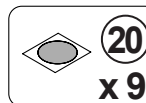
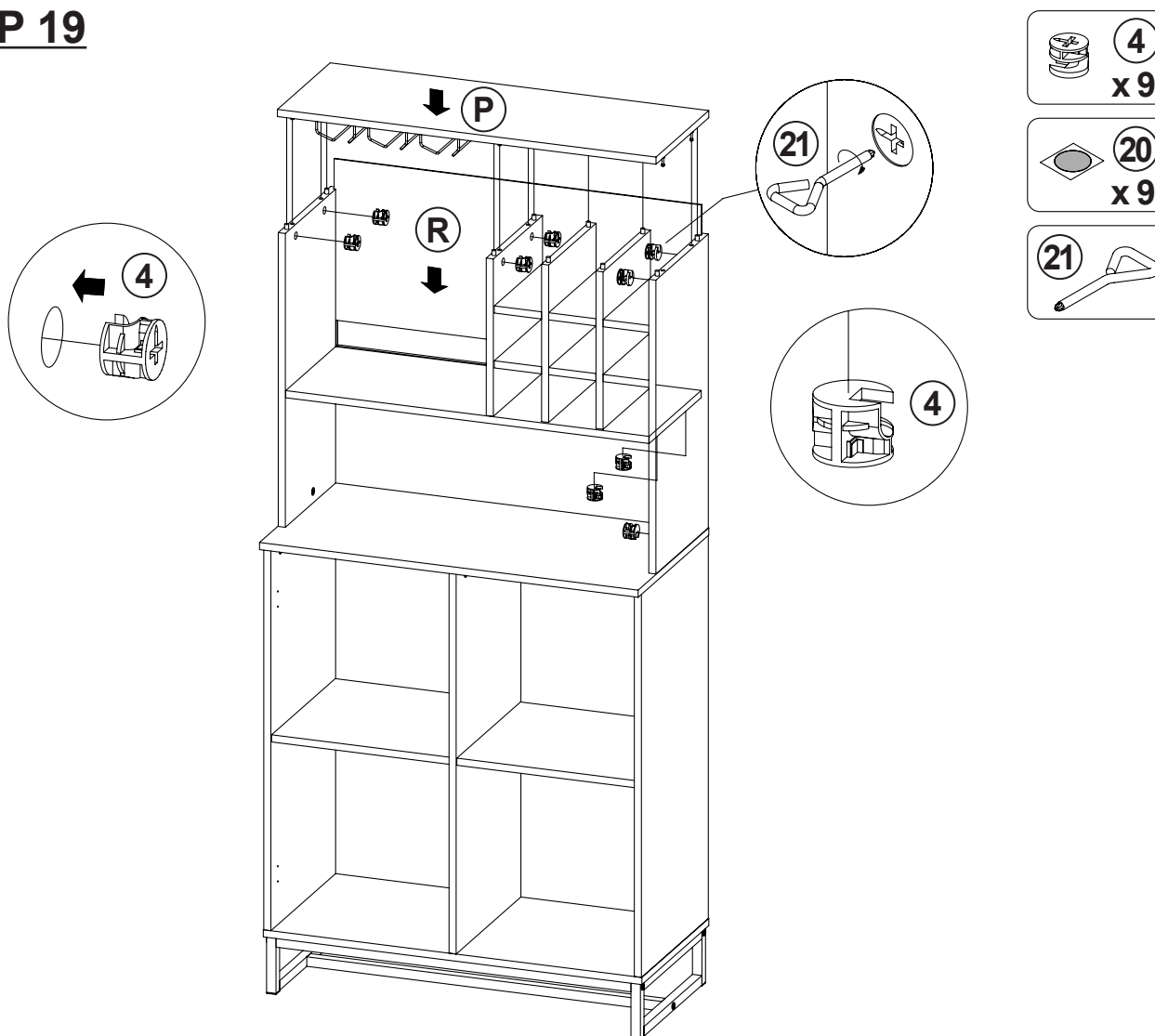

ITEM: **182082**

COASTER
FINE FURNITURE

STEP 20

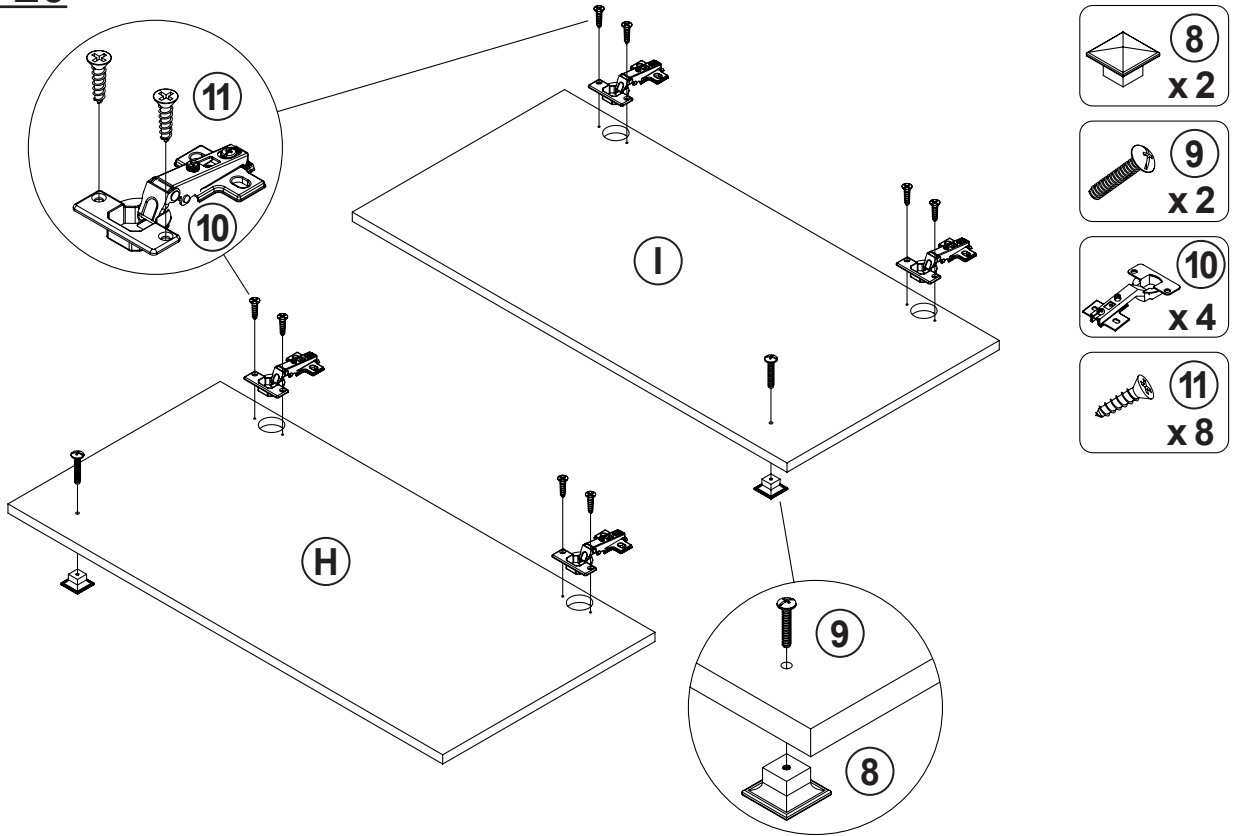

STEP 21

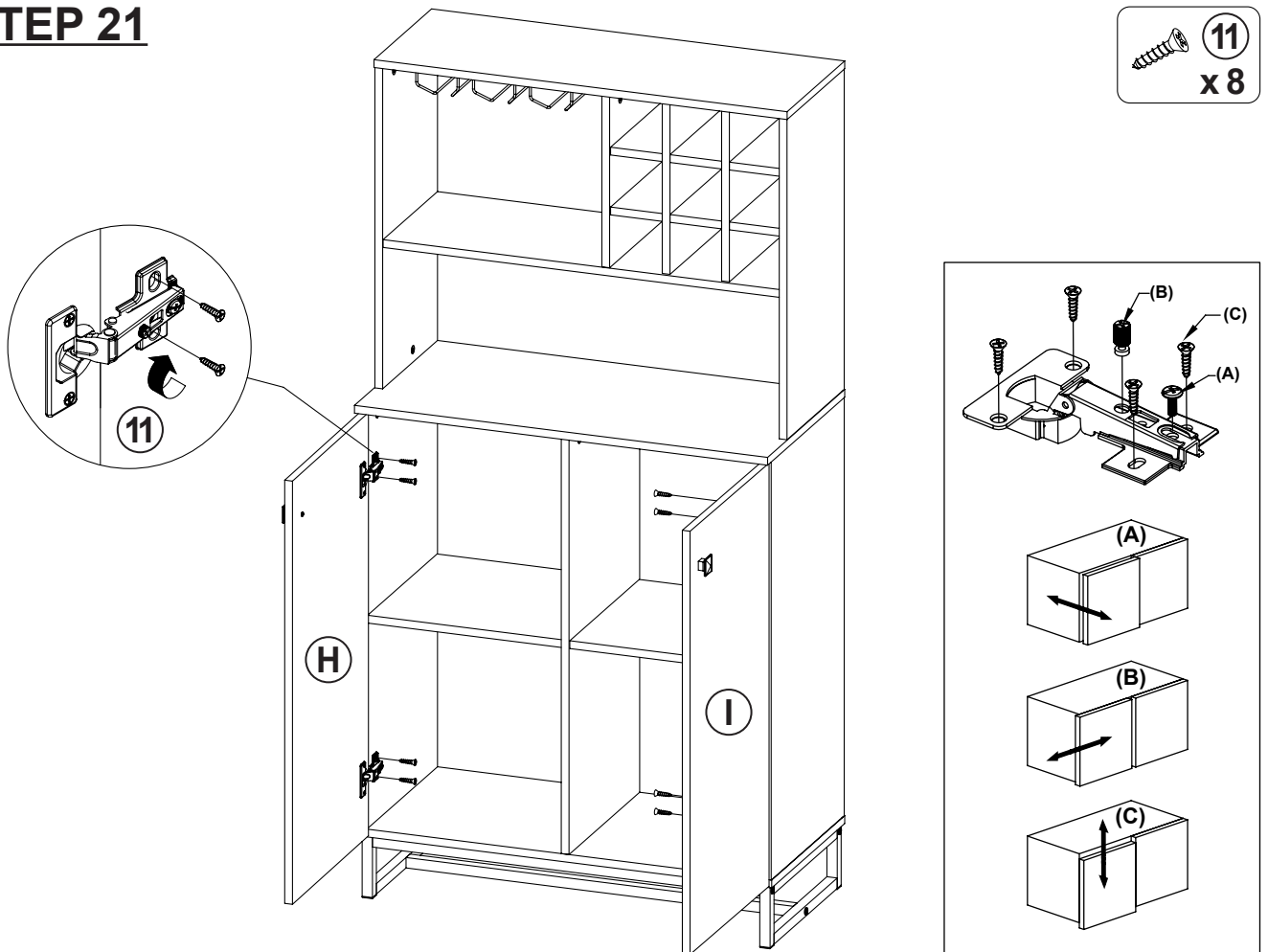

ITEM: **182082**

STEP 22

COASTER
FINE FURNITURE

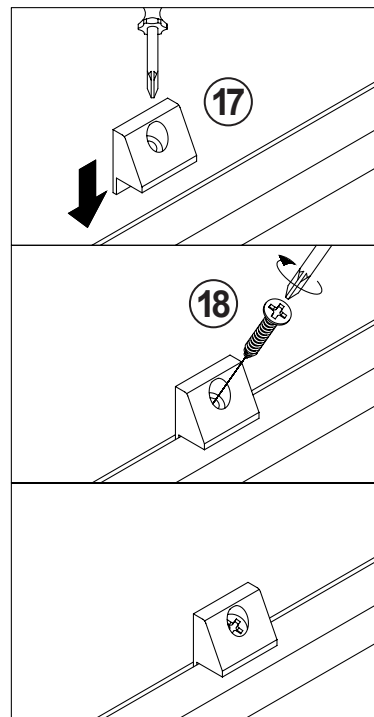
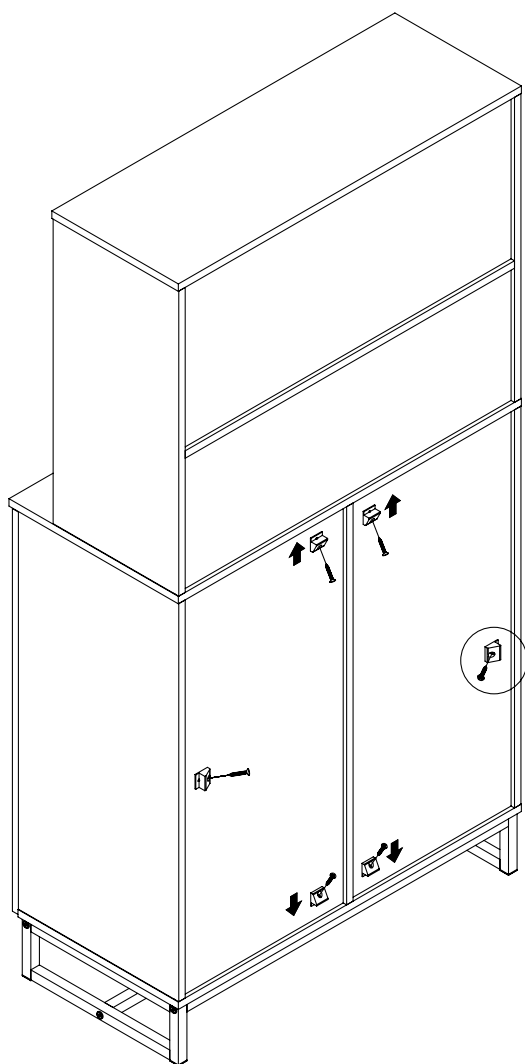

STEP 23

COMPLETE

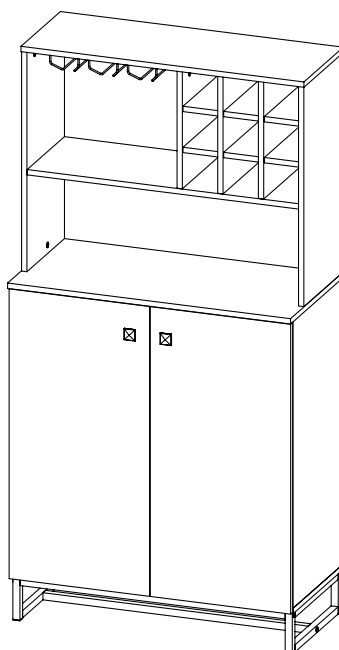

ANTI-TIPPING INSTALLMENT INSTRUCTIONS FURNITURE TIPPING RESTRAINT

WARNING

Injury may result from tipping furniture.
This restraint may protect against tipping furniture.
Do not allow children to climb on furniture.
This restraint is not a substitute for proper adult supervision.
Failure to detach this restraint before moving the furniture may result in injury and damage.

This restraint must be screwed to a wood stud on the wall, using the long screw provided.

STEP 1

Secure the bracket to the back top of the unit, using the short screw provided, as shown in the drawing.

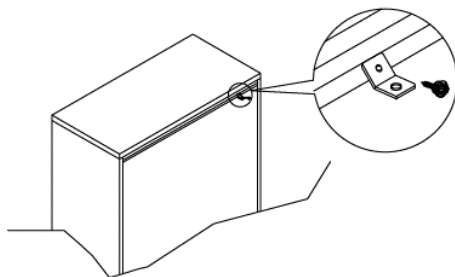

STEP 2

Locate the wood stud on the wall, and secure the other bracket, 2 inches below the back of the unit.

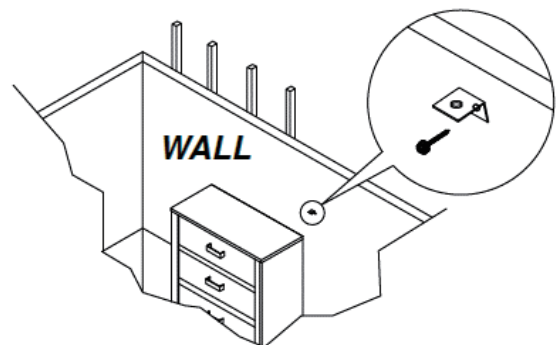

STEP 3

Place the furniture into position so both mounting brackets are vertically in line. Lace the end of the restraint strap through the larger hole in each mounting bracket. Bring both ends together and slide the flat end through the locking end, and drag it through, until the slack is removed. Ensure that the strap is securely laced and locked.

