

ASSEMBLY INSTRUCTIONS COASTER FINE FURNITURE

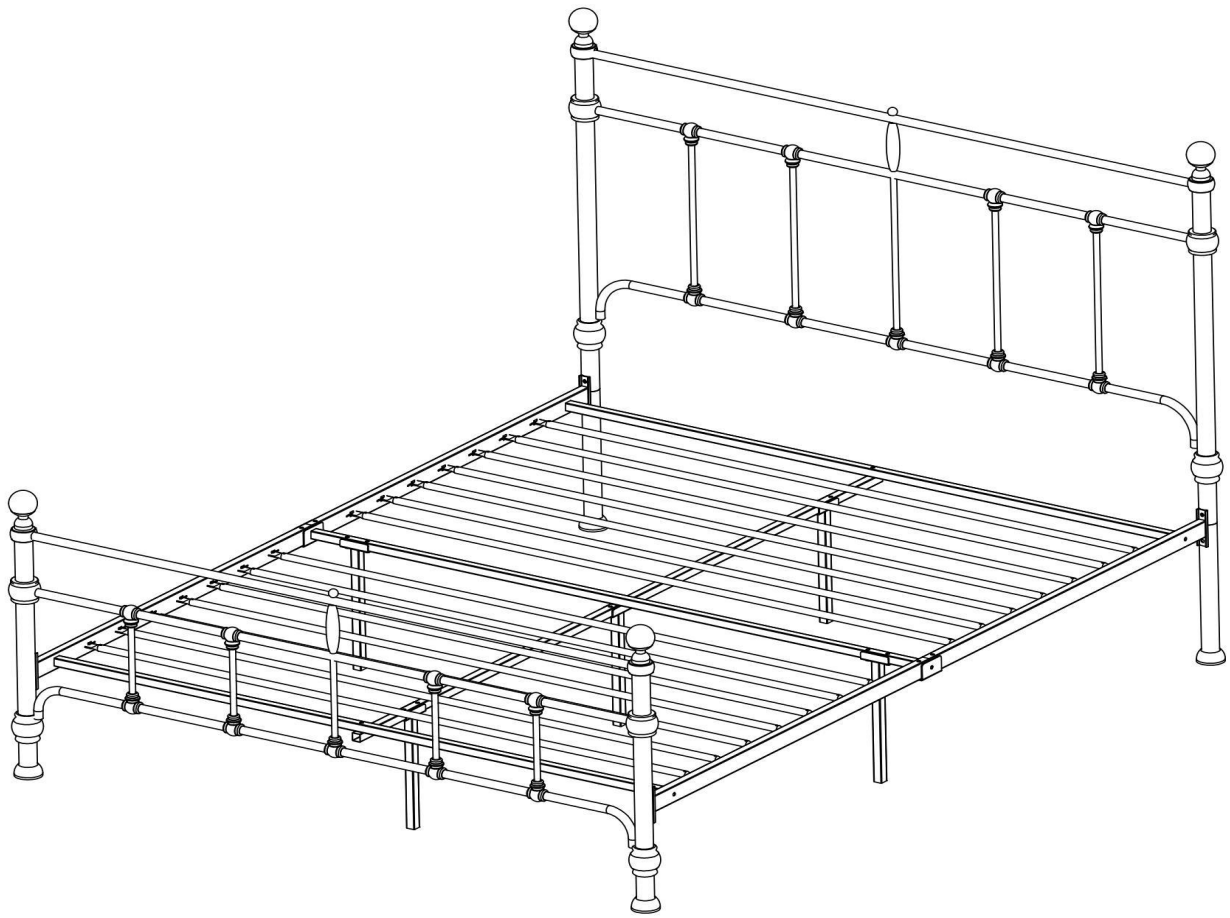

Fine Furniture for every stage of life

316001F
FULLBED

ITEM:316001F



ASSEMBLY INSTRUCTIONS

ASSEMBLY TIPS:

1. Remove hardware from box and sort by size.
2. Please check to see that all hardware and parts are present prior to start of assembly
3. Please follow attached instructions in the same sequence as numbered to assure fast & easy assembly.



WARNING!













1. Don't attempt to repair or modify parts that are broken or defective. Please contact the store immediately.
2. This product is for home use only and not intended for commercial establishments.











ASSEMBLY TIME

30 MINUTES

PARTS IDENTIFICATION

A HEADBOARD		1PCS	G SLAT		14PCS
B FOOTBOARD		1PCS	H LARGE FINIAL		4PCS
C RAIL		4PCS	I SMALL FINIAL		2PCS
D CENTER SUPPORT BAR		1PCS	J HEADBOARD AND FOOTBOARD SUPPORT BAR		2PCS
E SUPPORT LEG 1		2PCS	K SUPPORT LEG 2		2PCS
F HEADBOARD LEG		2PCS	L CENTER RAIL		2PCS
			M SUPPORT LEG 3		1PCS

Z- HARDWARE IDENTIFICATION

1 BOLT(M8x20MM)		8PCS	6 CURVED GASKET		2PCS
2 BOLT(M6x25MM)		10PCS	7 SLAT CONNECTOR		28PCS
3 BOLT(M6x45MM)		9PCS	8 BOLT(M6x30MM)		4PCS
4 BOLT(M8x20MM)		2PCS	9 BOLT(M6x17MM)		2PCS
5 ALLEN WRENCH		2PCS			

ITEM: 316001F

ASSEMBLY INSTRUCTIONS



STEP 1

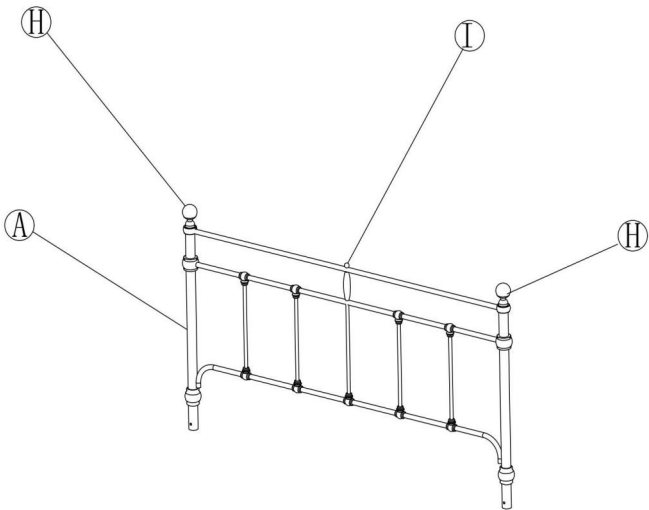

STEP 2

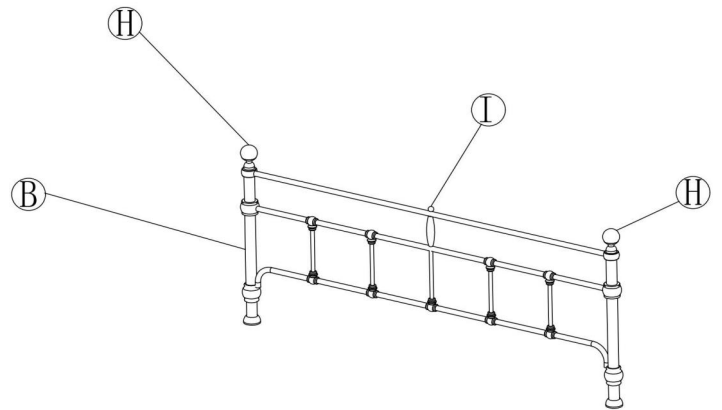

STEP 3

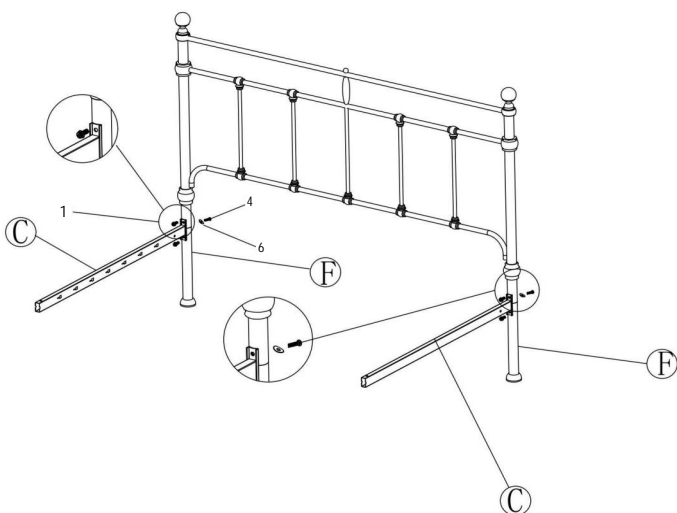

1	X 4	4	X 2	6	X 2
M8X20		M8X20		φ22Xφ8.5	

STEP 4

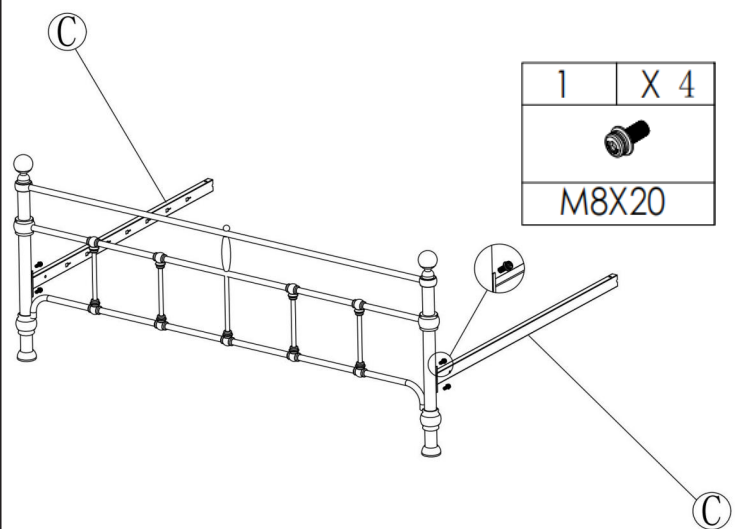

1	X 4
M8X20	

ITEM: 316001F

ASSEMBLY INSTRUCTIONS



STEP 5

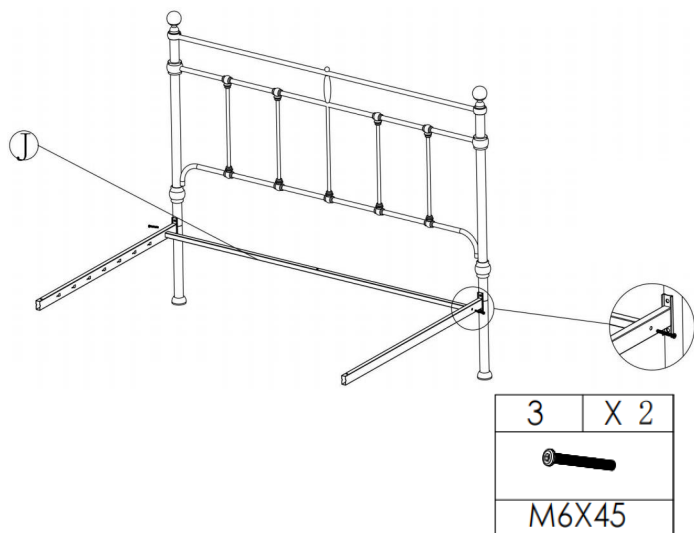

STEP 6

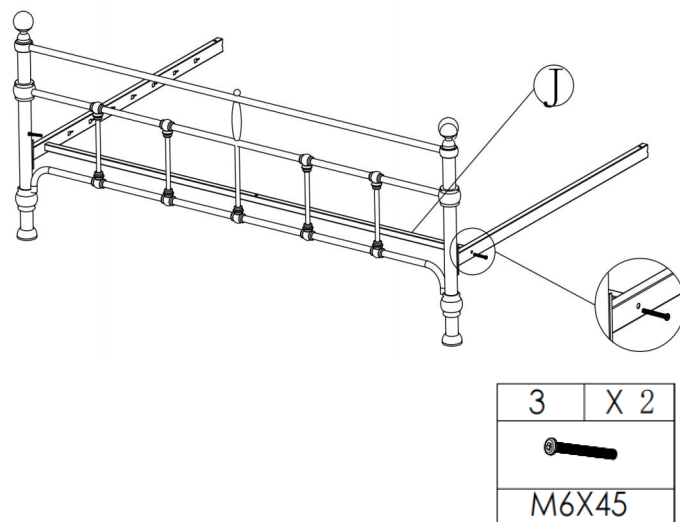

STEP 7

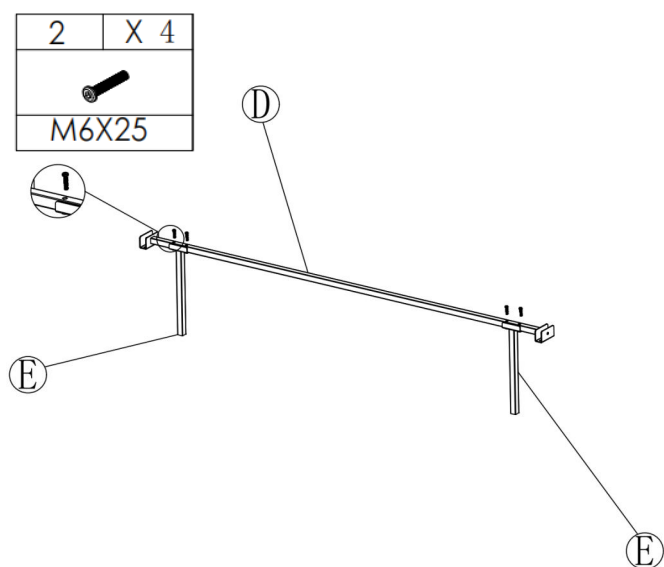

STEP 8

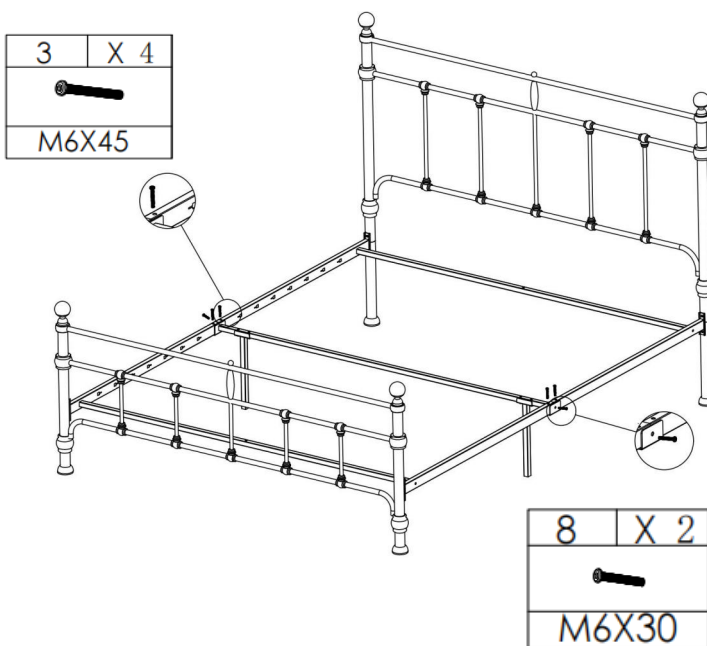

ITEM: 316001F

ASSEMBLY INSTRUCTIONS



STEP 9

2	X 6
M6X25	

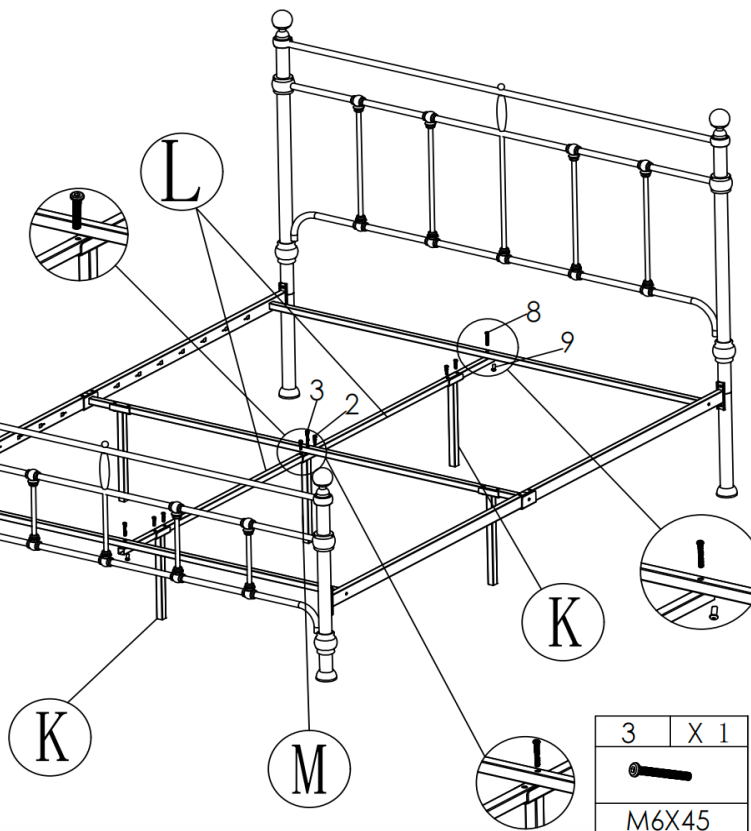

8	X 2	9	X 2
M6X30		M6X17	

3	X 1
M6X45	

STEP 10

7	X 28

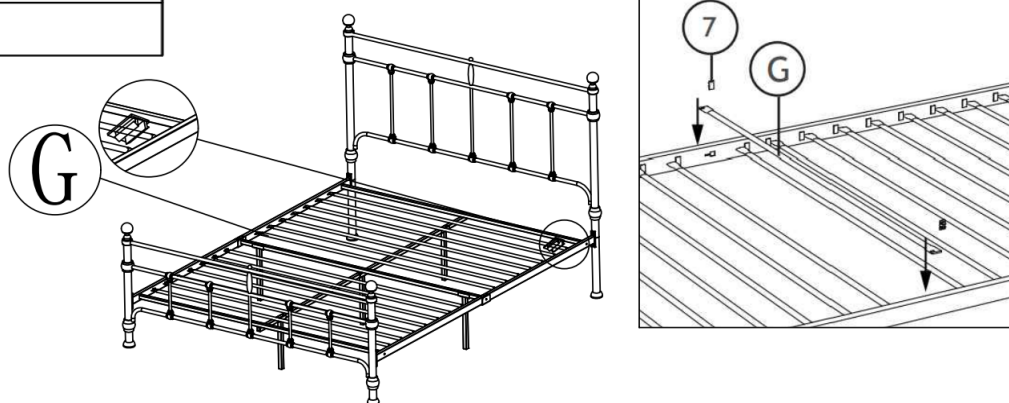
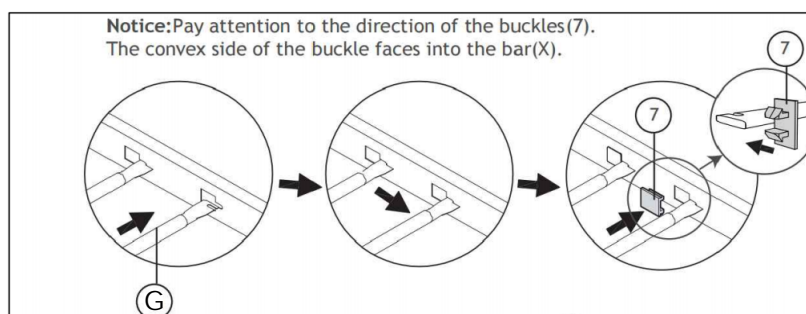

Note : Dimension tolerance $\pm 5\%$

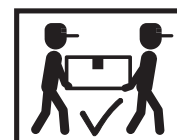

ITEM: 316001F

ASSEMBLY INSTRUCTIONS

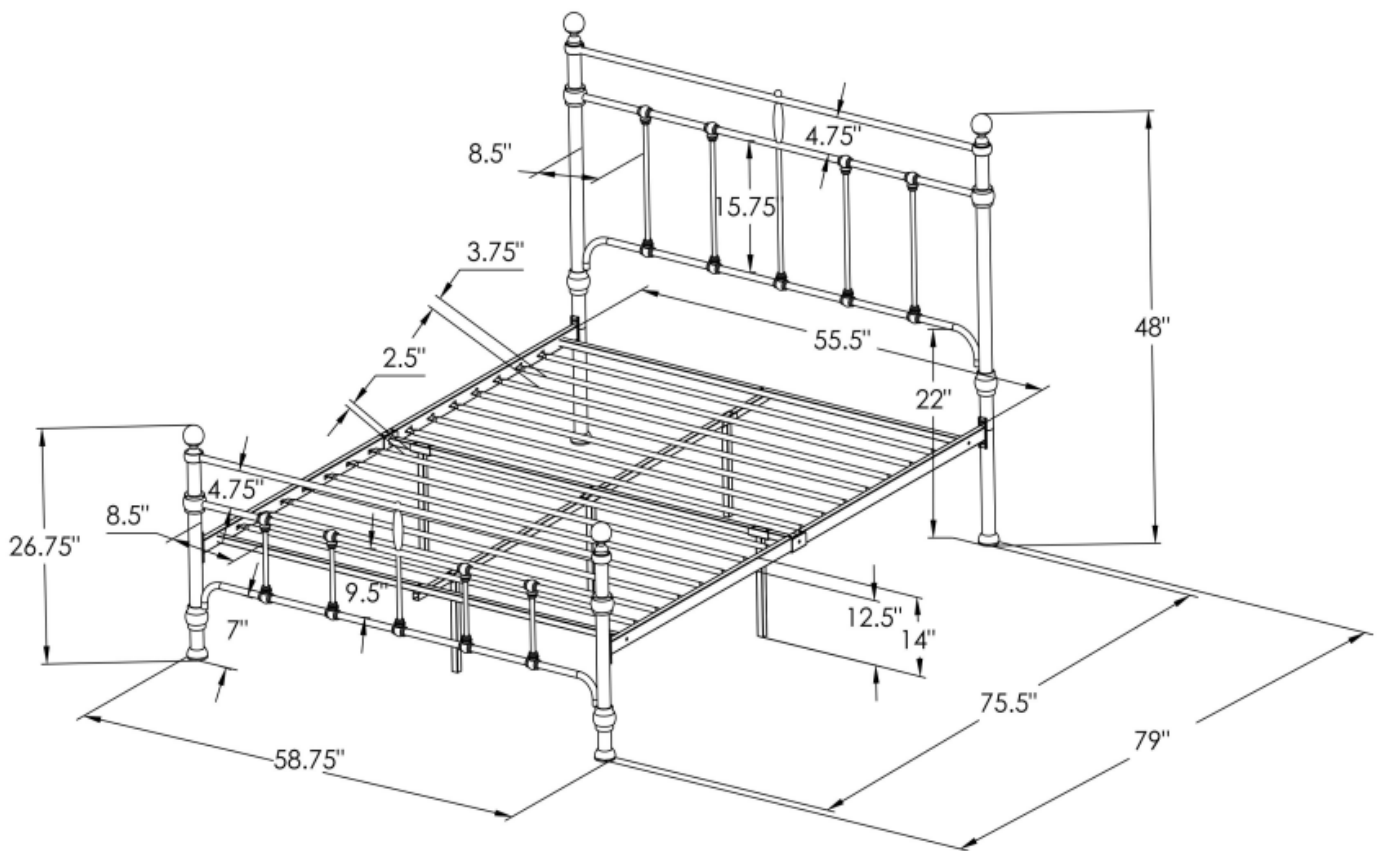

Note : Dimension tolerance $\pm 5\%$

