

ASSEMBLY INSTRUCTIONS
COASTER FINE FURNITURE



Fine Furniture for every stage of life

109352
Side Chair

ITEM: **109352**



ASSEMBLY INSTRUCTIONS

ASSEMBLY TIPS:

1. Remove hardware from box and sort by size.
2. Please check to see that all hardware and parts are present prior to start of assembly.
3. Please follow attached instructions in the same sequence as numbered to assure fast & easy assembly.



WARNING!



1. Don't attempt to repair or modify parts that are broken or defective. Please contact the store immediately.
2. This product is for home use only and not intended for commercial establishments.



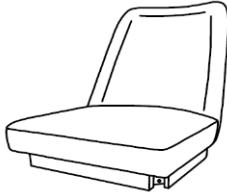

ASSEMBLY TIME

10 MINUTES

PARTS IDENTIFICATION

A	SEAT AND BACK		1PC
B	FRONT LEG		2PCS
C	BACK LEG		2PCS

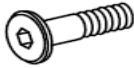
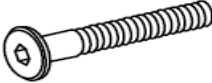
HARDWARE IDENTIFICATION

1	ALLEN WRENCH (M4 x 100mm - BLK)		1PC
2	SHORT BOLT (M6 x 40mm - RBW)		4PCS
3	LONG BOLT (M6 x 60mm - RBW)		4PCS
4	LOCK WASHER (M6 - RBW)		8PCS
5	FLAT WASHER (M6 - RBW)		8PCS

NOTE:

Quantities shown are for one chair.

ITEM: **109352**

ASSEMBLY INSTRUCTIONS
STEP 1

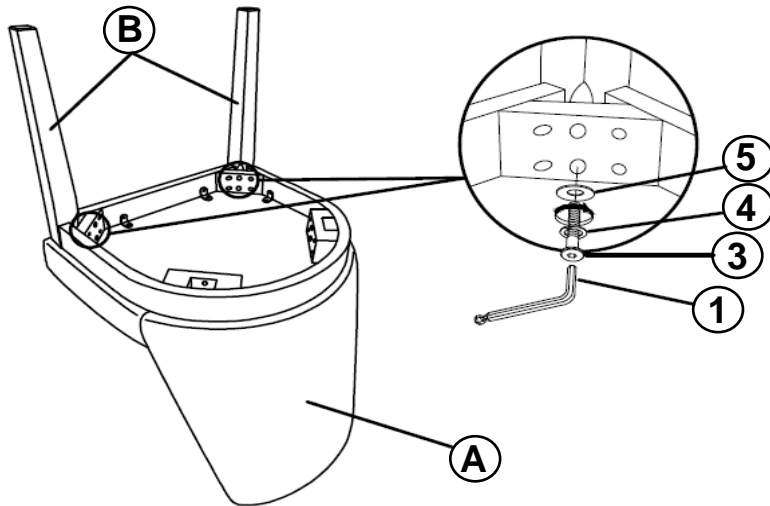

STEP 2

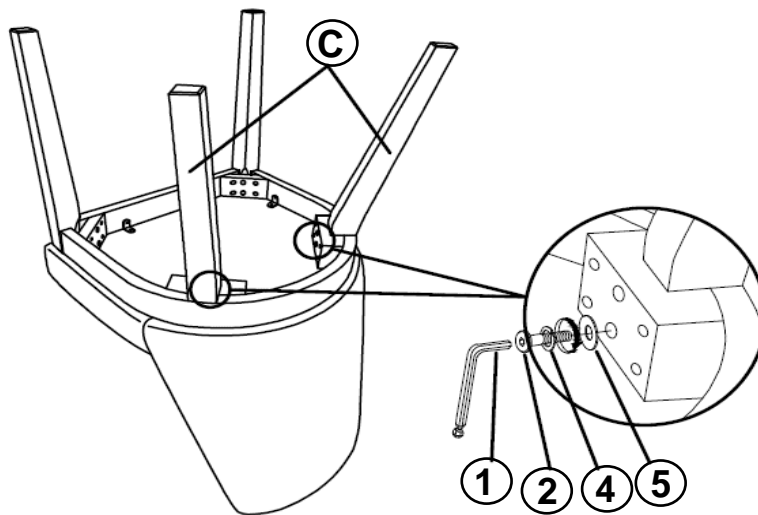

STEP 3
COMPLETE

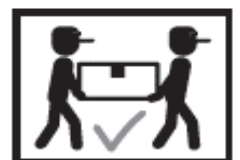
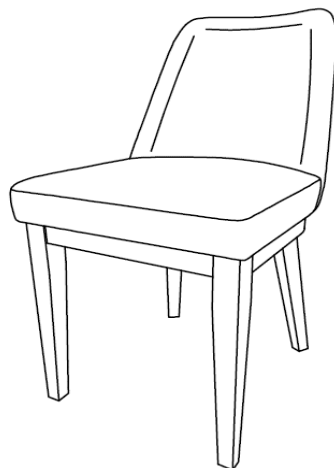

ITEM: 109352

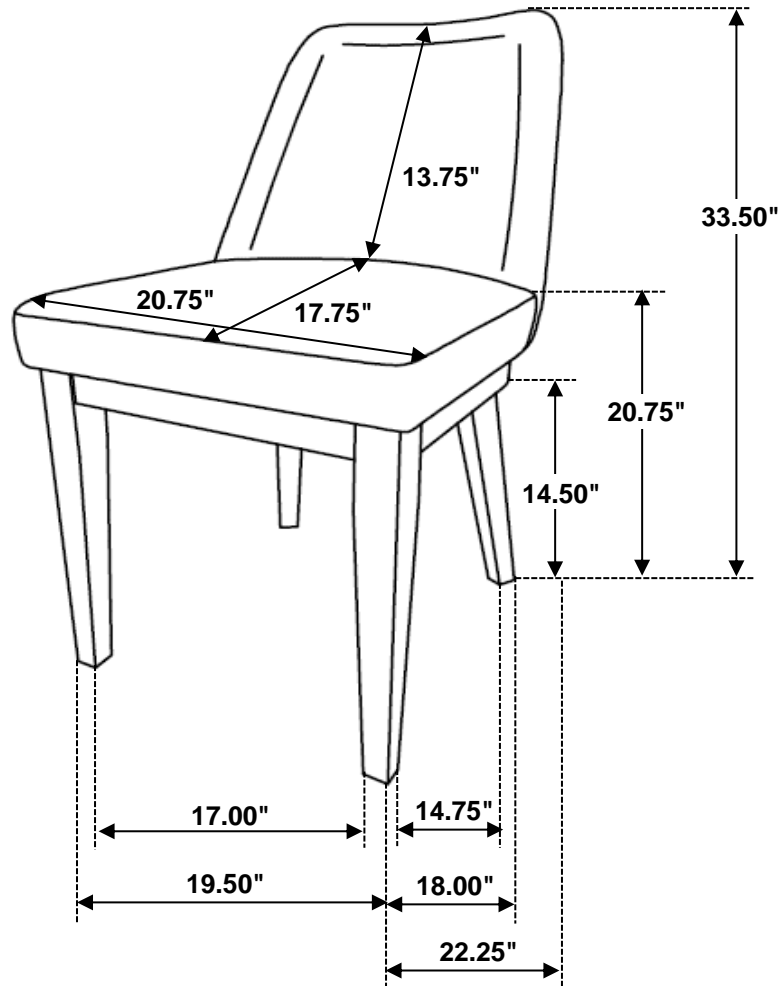

Note: Dimension tolerance $\pm 5\%$