

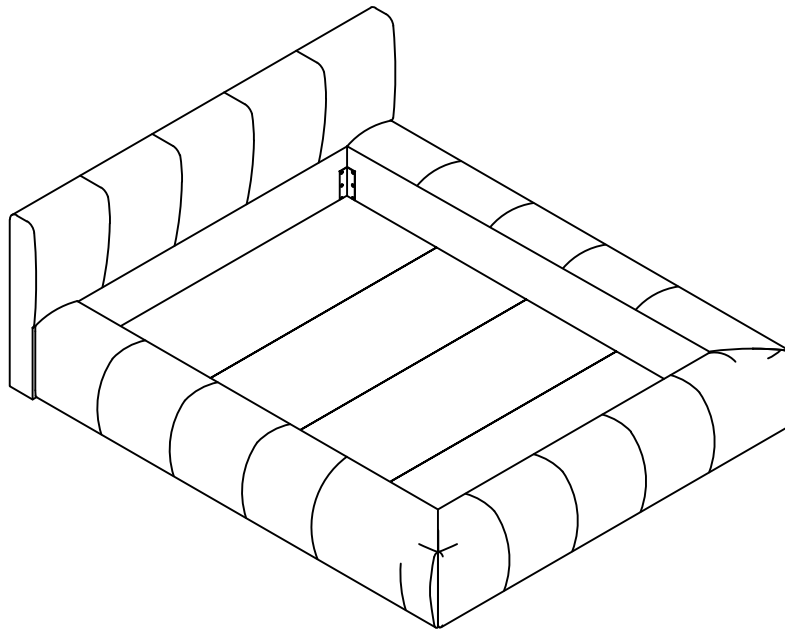

ASSEMBLY INSTRUCTIONS
COASTER FINE FURNITURE



Fine Furniture for every stage of life

315981KW(B1&B2)
California King Bed

ITEM: 315981KW(B1&B2)



ASSEMBLY INSTRUCTIONS

ASSEMBLY TIPS:

1. Remove hardware from box and sort by size.
2. Please check to see that all hardware and parts are present prior to start of assembly.
3. Please follow attached instructions in the same sequence as numbered to assure fast & easy assembly.



WARNING!

1. Don't attempt to repair or modify parts that are broken or defective. Please contact the store immediately.
2. This product is for home use only and not intended for commercial establishments.



ASSEMBLY TIME

15 MINUTES

PARTS IDENTIFICATION

B1 (BOX 1)

A HEABOARD PANEL

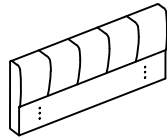

1PC

C CONCEAL PANEL



4PCS

B ROLL SLAT (13PCS)



1SET

I FEET



4PCS

B2 (BOX 2)

D FOOTBOARD PANEL

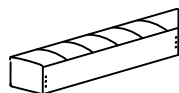

1PC

G CENTER RAIL



1PC

E LEFT BED RAIL

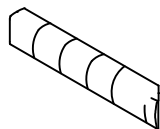

1PC

H BED SLAT SUPPORT WITH LEVELER



3PCS

F RIGHT BED RAIL

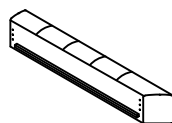

1PC

I FEET



9PCS

ITEM: 315981KW(B1&B2)



ASSEMBLY INSTRUCTIONS

ASSEMBLY TIPS:

1. Remove hardware from box and sort by size.
2. Please check to see that all hardware and parts are present prior to start of assembly.
3. Please follow attached instructions in the same sequence as numbered to assure fast & easy assembly.







WARNING!

1. Don't attempt to repair or modify parts that are broken or defective. Please contact the store immediately.
2. This product is for home use only and not intended for commercial establishments.

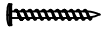
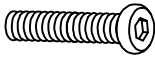
HARDWARE IDENTIFICATION

Z-B2 (BOX 2) - HARDWARE PACK IS LOCATED IN 315981KW(B2)

1	ALLEN WRENCH (M5 x 75mm x 32mm)		1PC	5	FLAT HEAD SCREW (M4 x 38mm - BLK)		22PCS
2	BOLT (Ø 5/16" x 38mm - BLK)		24PCS	6	METAL BRACKET (150mm x 45mm x 45mm x 3mm - BLK)		4PCS
3	FLAT WASHER (Ø 5/16" x 19mm - BLK)		24PCS				
4	LOCK WASHER (Ø 5/16" x R6.5 - BLK)		24PCS				

NOTE:

Phillips head screw driver is required in the assembly process; however, manufacturer does not provide this item.

ITEM: 315981KW(B1&B2)

ASSEMBLY INSTRUCTIONS



STEP 1

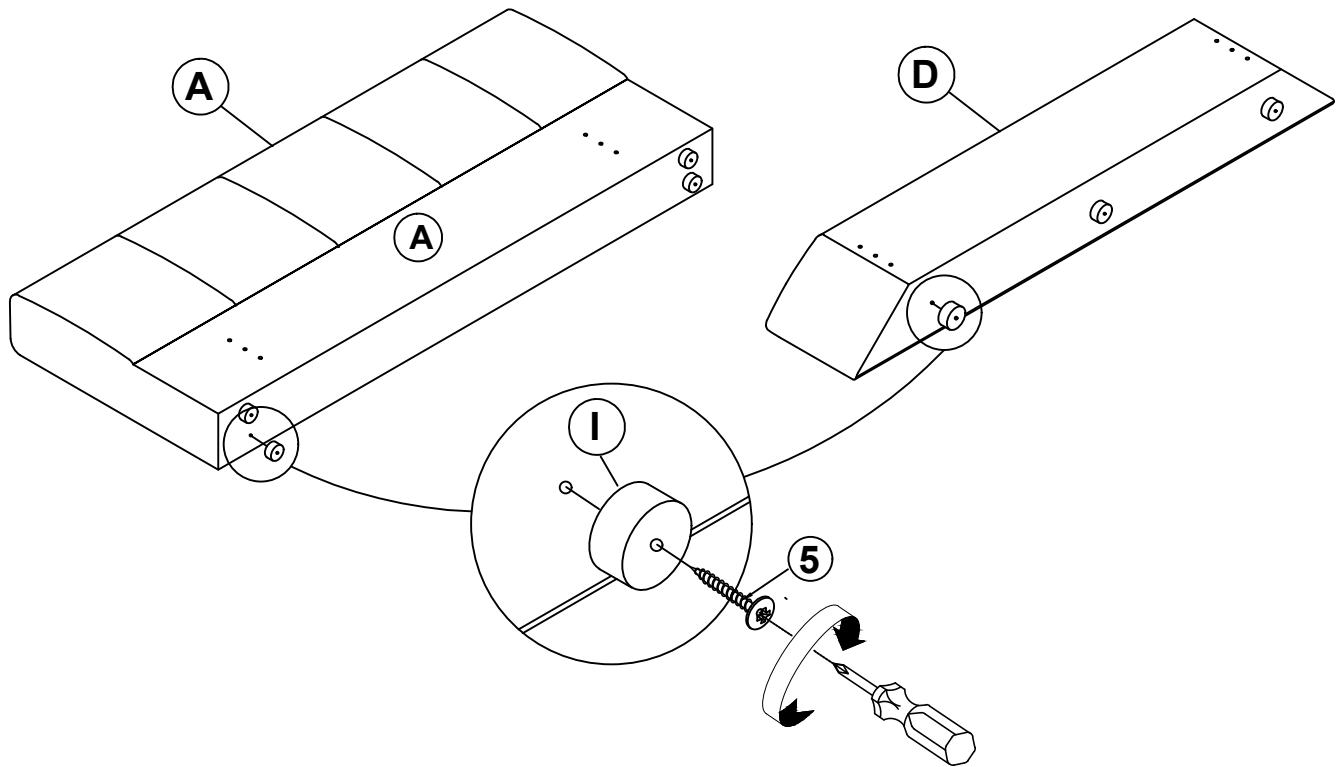

STEP 2

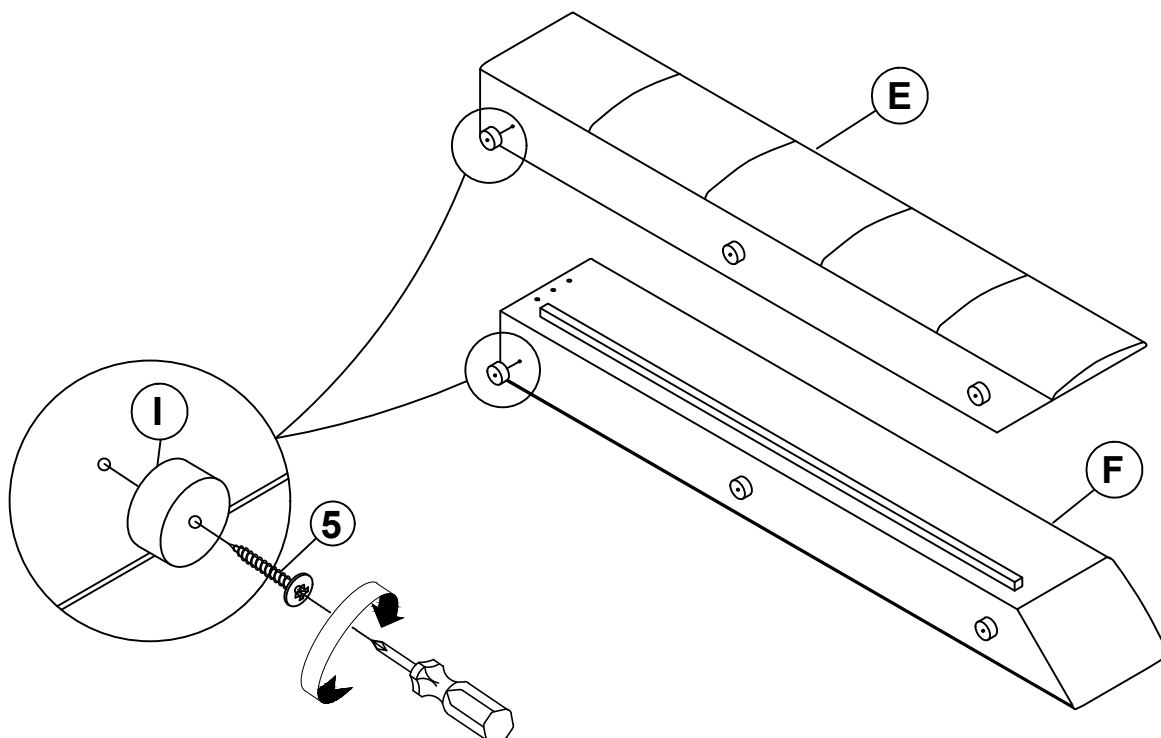

ITEM: 315981KW(B1&B2)

ASSEMBLY INSTRUCTIONS



STEP 3

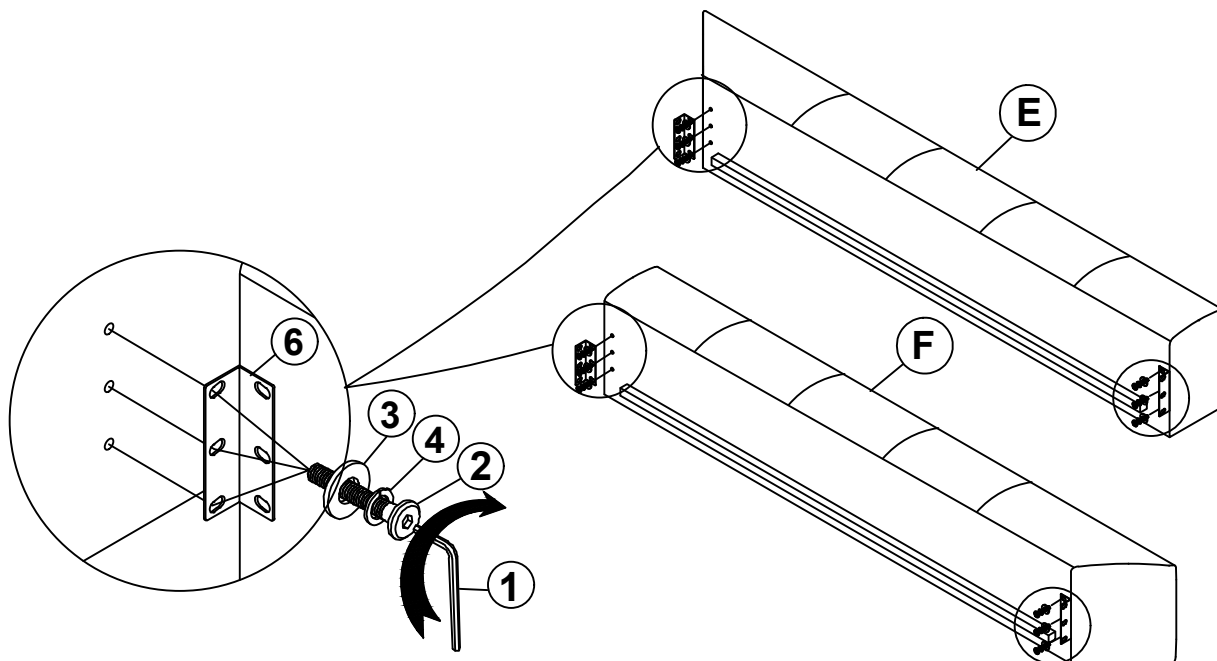

STEP 4

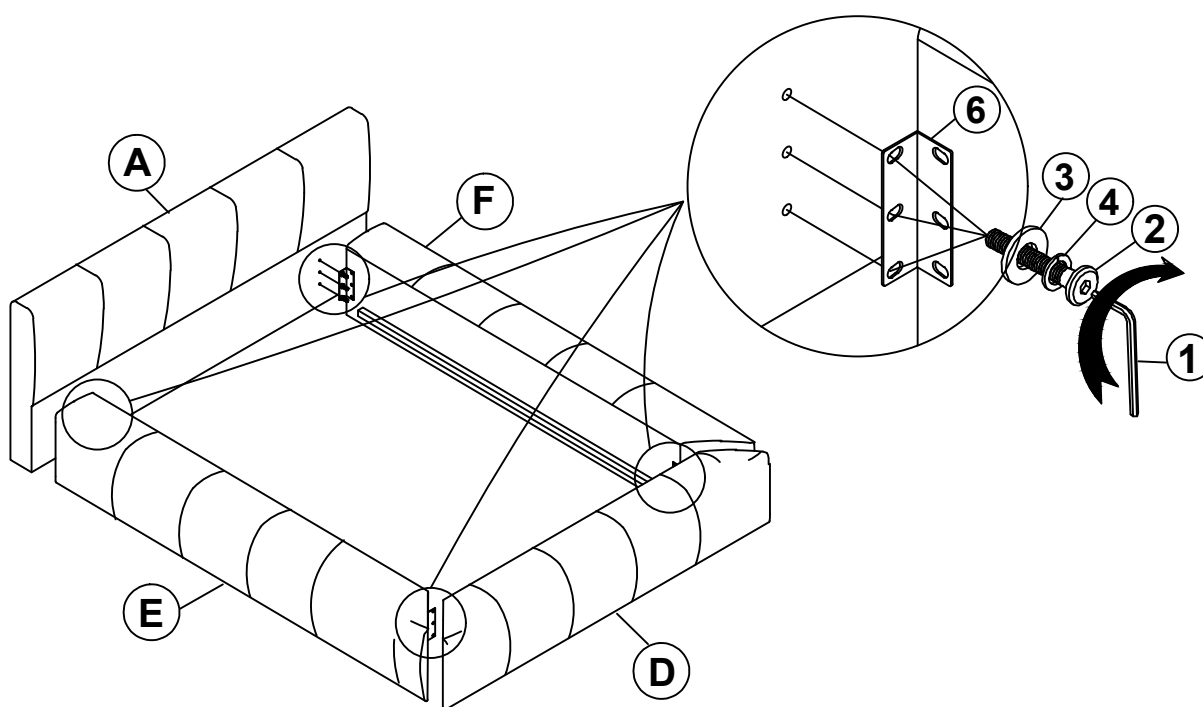

ITEM: 315981KW(B1&B2)

ASSEMBLY INSTRUCTIONS



STEP 5

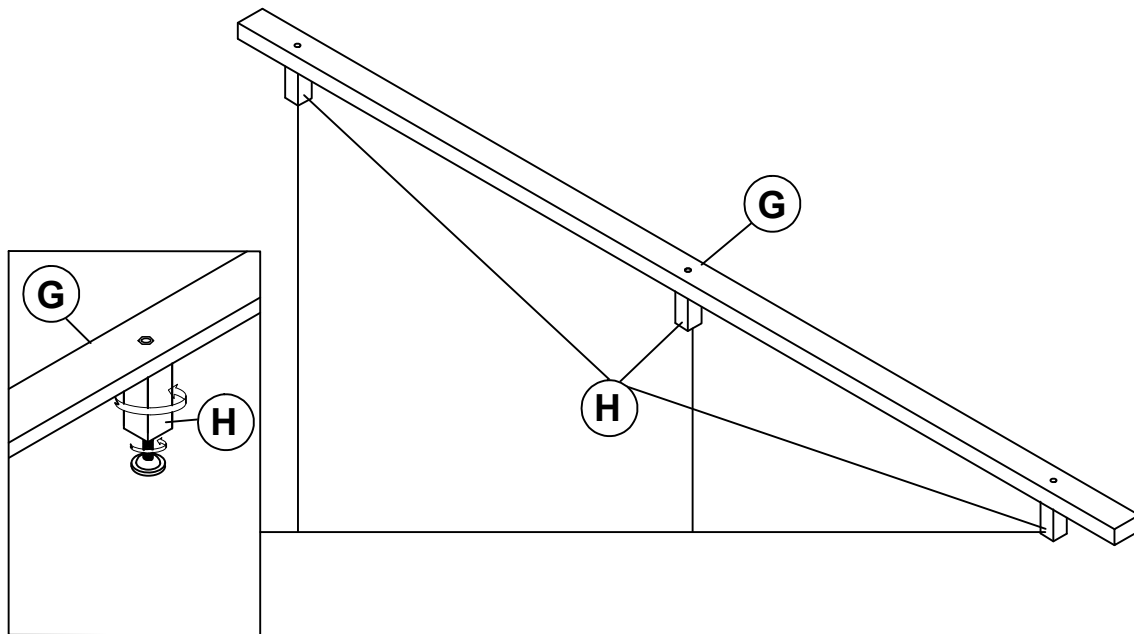

STEP 6

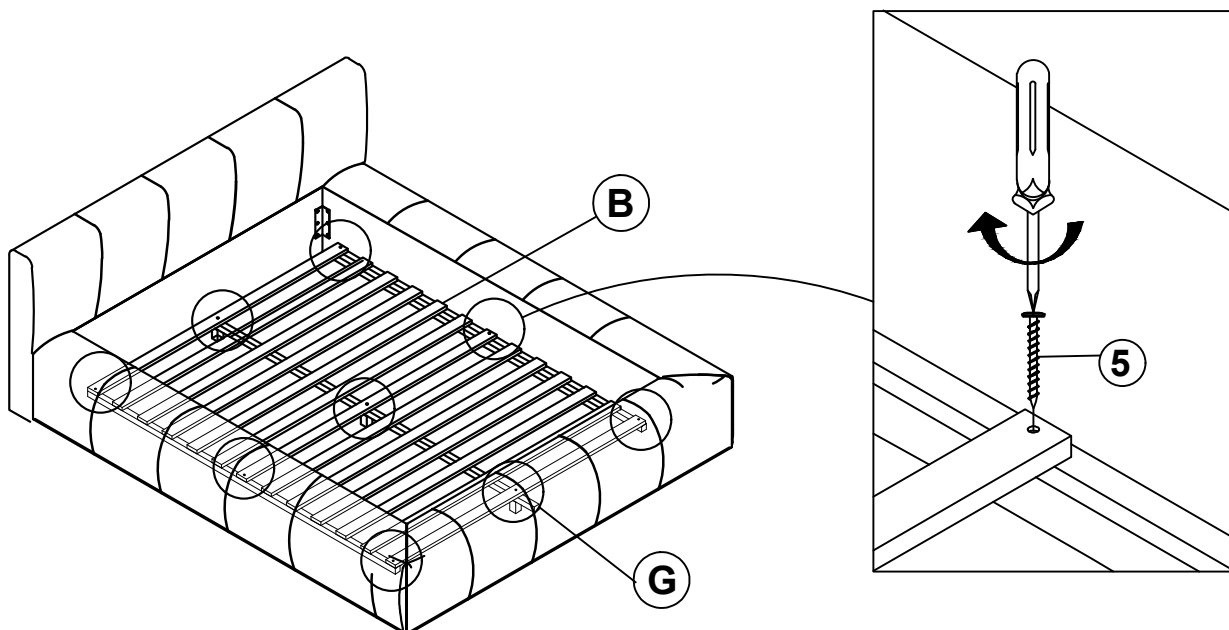

ITEM: **315981KW(B1&B2)**

ASSEMBLY INSTRUCTIONS



STEP 7

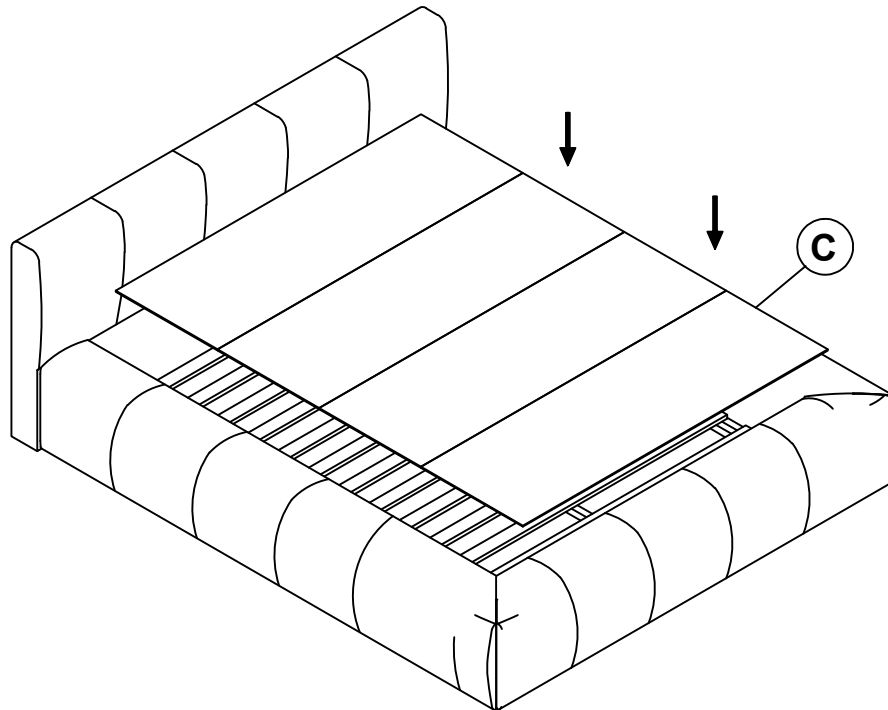

STEP 8
COMPLETE

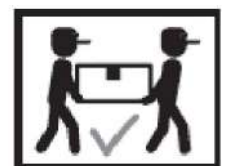
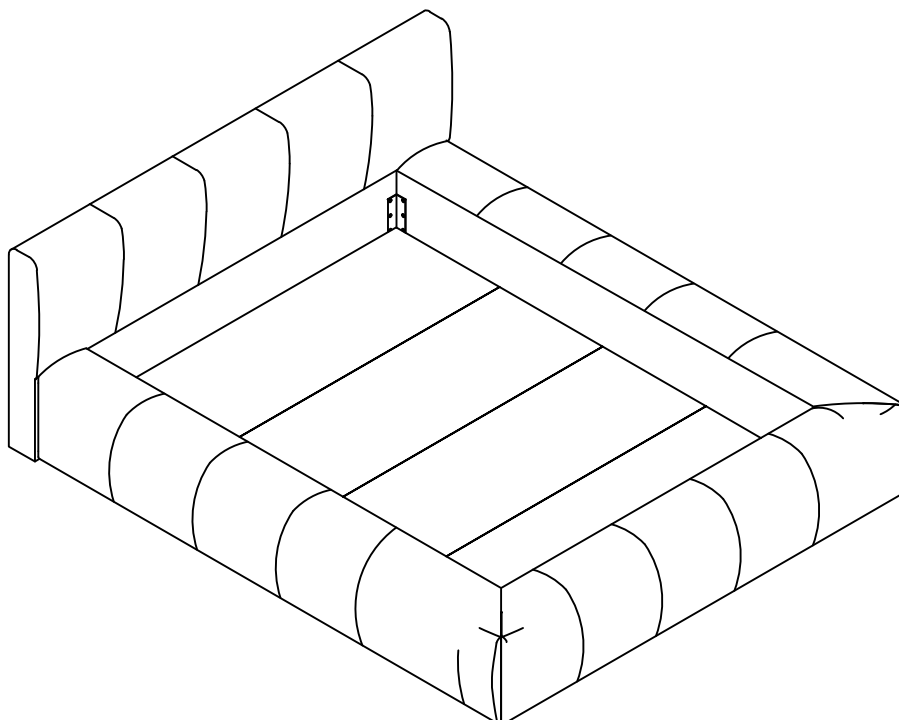

ITEM: **315981KW(B1&B2)**



Inner Size: 73.00"W X 85.00"D

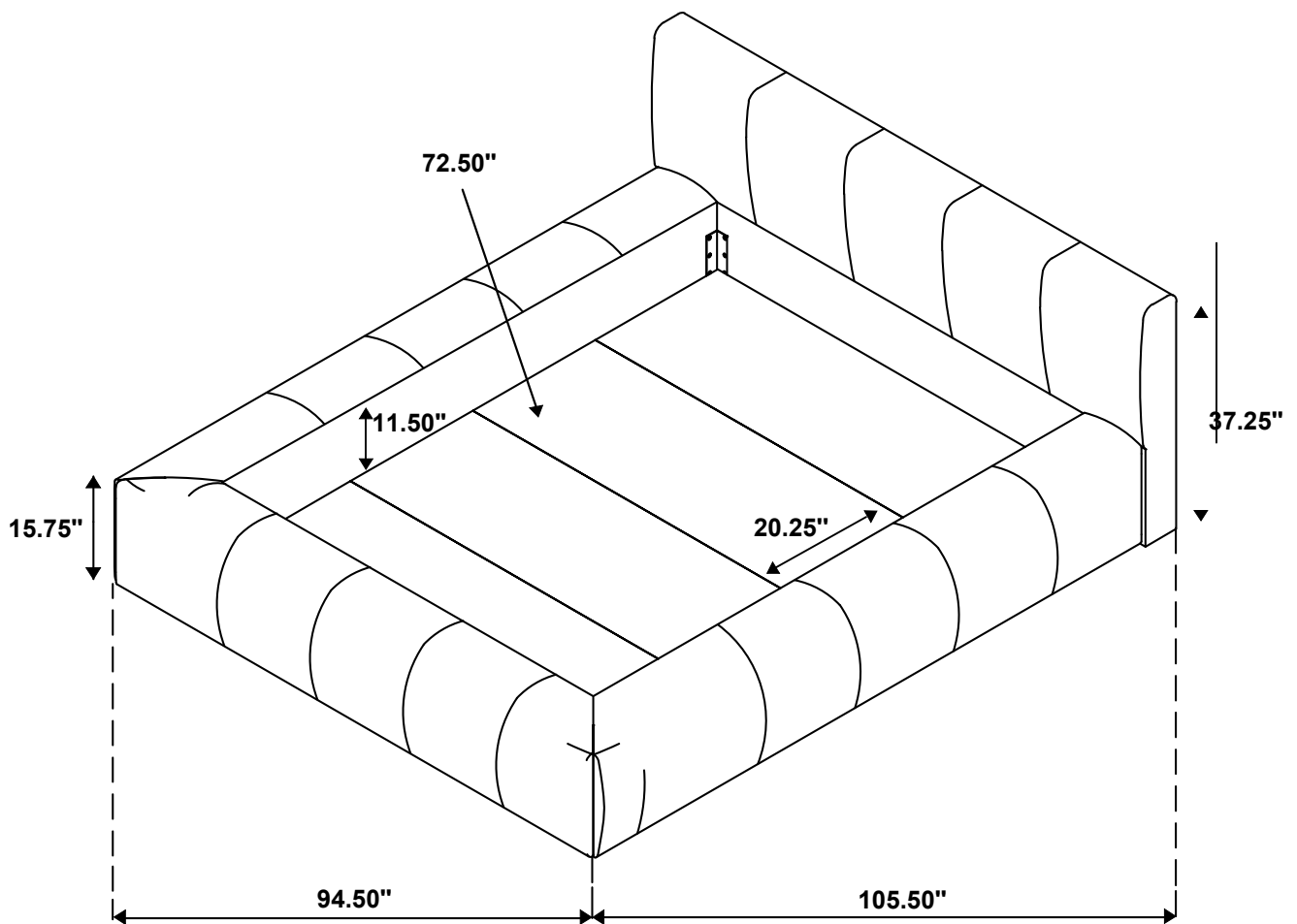

Note: Dimension tolerance $\pm 5\%$