

*ASSEMBLY INSTRUCTIONS*  
*COASTER FINE FURNITURE*

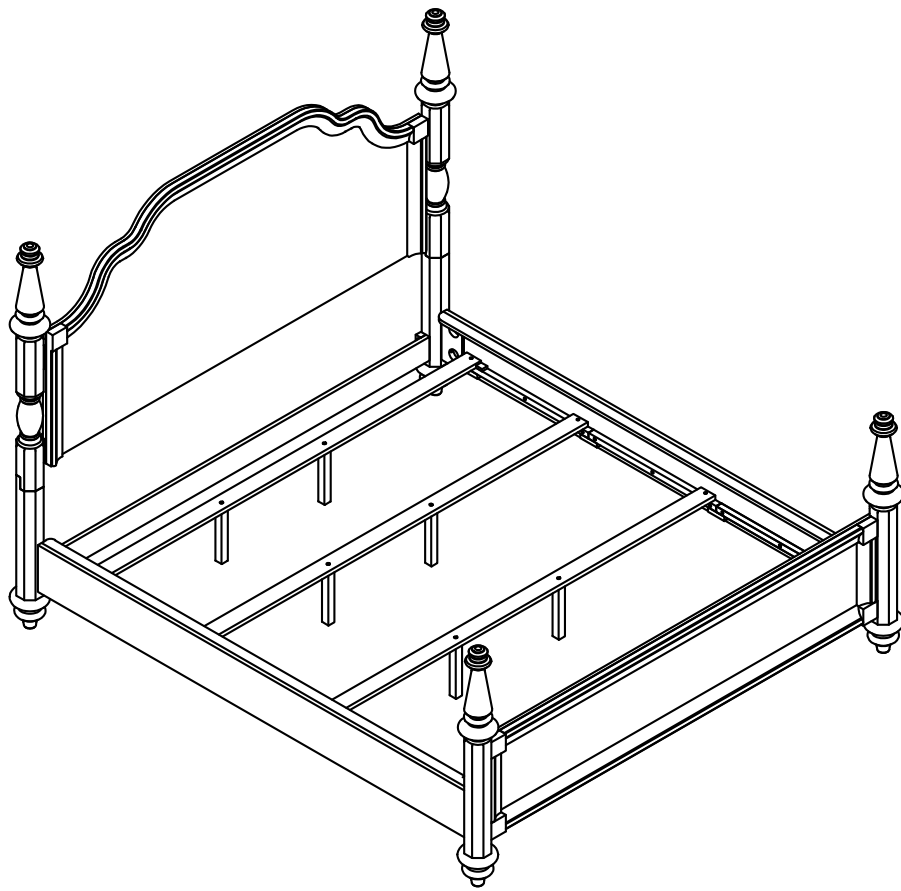

*Fine Furniture for every stage of life*

**223631KW (B1-B3)**  
**California King Bed**

# ITEM: 223631KW(B1-B3)



## ASSEMBLY INSTRUCTIONS

### ASSEMBLY TIPS:

1. Remove hardware from box and sort by size.
2. Please check to see that all hardware and parts are present prior to start of assembly.
3. Please follow attached instructions in the same sequence as numbered to assure fast & easy assembly.



### WARNING!

1. Don't attempt to repair or modify parts that are broken or defective. Please contact the store immediately.
2. This product is for home use only and not intended for commercial establishments.







ASSEMBLY TIME

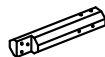

30 MINUTES

## PARTS IDENTIFICATION



### B1 (BOX 1)

<p><b>A</b> HEADBOARD PANEL</p>  <p>1PC</p>	<p><b>B</b> HEADBOARD BOTTOM RAIL</p>  <p>1PC</p>
<p><b>C</b> RIGHT HEADBOARD LEG</p>  <p>1PC</p>	<p><b>D</b> LEFT HEADBOARD LEG</p>  <p>1PC</p>
<p><b>E</b> FINIAL</p>  <p>2PCS</p>	<p><b>F</b> BUN FOOT</p>  <p>2PCS</p>

### B2 (BOX 2)

<p><b>E</b> FINIAL</p>  <p>2PCS</p>	<p><b>F</b> BUN FOOT</p>  <p>2PCS</p>
<p><b>G</b> FOOTBOARD PANEL</p>  <p>1PC</p>	

### B3 (BOX 3)

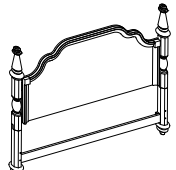
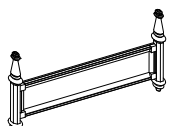
<p><b>H</b> BED RAIL</p>  <p>2PCS</p>	<p><b>I</b> BED SLAT</p>  <p>4PCS</p>
<p><b>J</b> BED SLAT SUPPORT WITH LEVELER</p>  <p>8PCS</p>	
<p><b>HB</b> 223631KW(B1) FROM BOX 1 HEADBOARD COMPLETE</p>  <p>1PC</p>	<p><b>FB</b> 223631KW(B2) FROM BOX 2 FOOTBOARD COMPLETE</p>  <p>1PC</p>

### NOTE:

Phillips head screw driver is required in the assembly process; however, manufacturer does not provide this item.

# ITEM: 223631KW(B1-B3)



## ASSEMBLY INSTRUCTIONS

### ASSEMBLY TIPS:

1. Remove hardware from box and sort by size.
2. Please check to see that all hardware and parts are present prior to start of assembly.
3. Please follow attached instructions in the same sequence as numbered to assure fast & easy assembly.







### WARNING!





1. Don't attempt to repair or modify parts that are broken or defective. Please contact the store immediately.
2. This product is for home use only and not intended for commercial establishments.

## HARDWARE IDENTIFICATION

### Z-B1 (BOX 1) - HARDWARE PACK IS LOCATED IN 223631KW(B1)

1	<b>BOLT</b> ( $\phi$ 5/16" x 50MM - RBW)		10PCS	2	<b>LOCK WASHER</b> ( $\phi$ 5/16" - RBW)		10PCS
3	<b>FLAT WASHER</b> ( $\phi$ 5/16" - RBW)		10PCS	4	<b>ALLEN WRENCH</b> (M4 x 60MM - RBW)		1PC

### Z-B2 (BOX 2) - HARDWARE PACK IS LOCATED IN 223631KW(B3)

5	<b>THREADED BOLT</b> ( $\phi$ 5/16" x 90MM - RBW)		8PCS	6	<b>HALF ROUND NUT</b> ( $\phi$ 5/16" - RBW)		8PCS
7	<b>HEX NUT</b> ( $\phi$ 5/16" x 14MM - RBW)		8PCS	8	<b>WRENCH</b> (14MM - RBW)		1PC
9	<b>FLAT HEAD SCREW</b> ( $\phi$ 4 x 30MM - RBW)		8PCS				

### NOTE:

Phillips head screw driver is required in the assembly process; however, manufacturer does not provide this item.

# ITEM: 223631KW(B1-B3)

## ASSEMBLY INSTRUCTIONS

### STEP 1

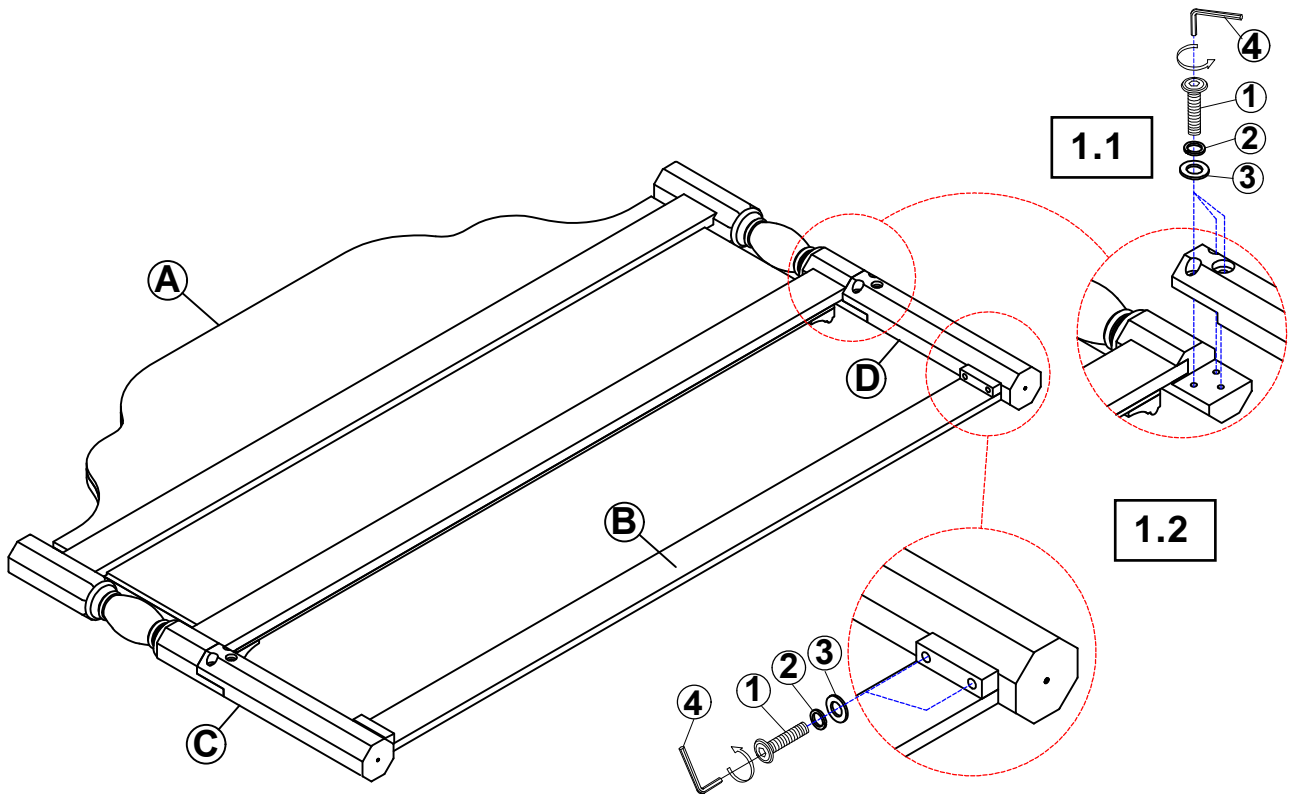

\* BACK VIEW

### STEP 2

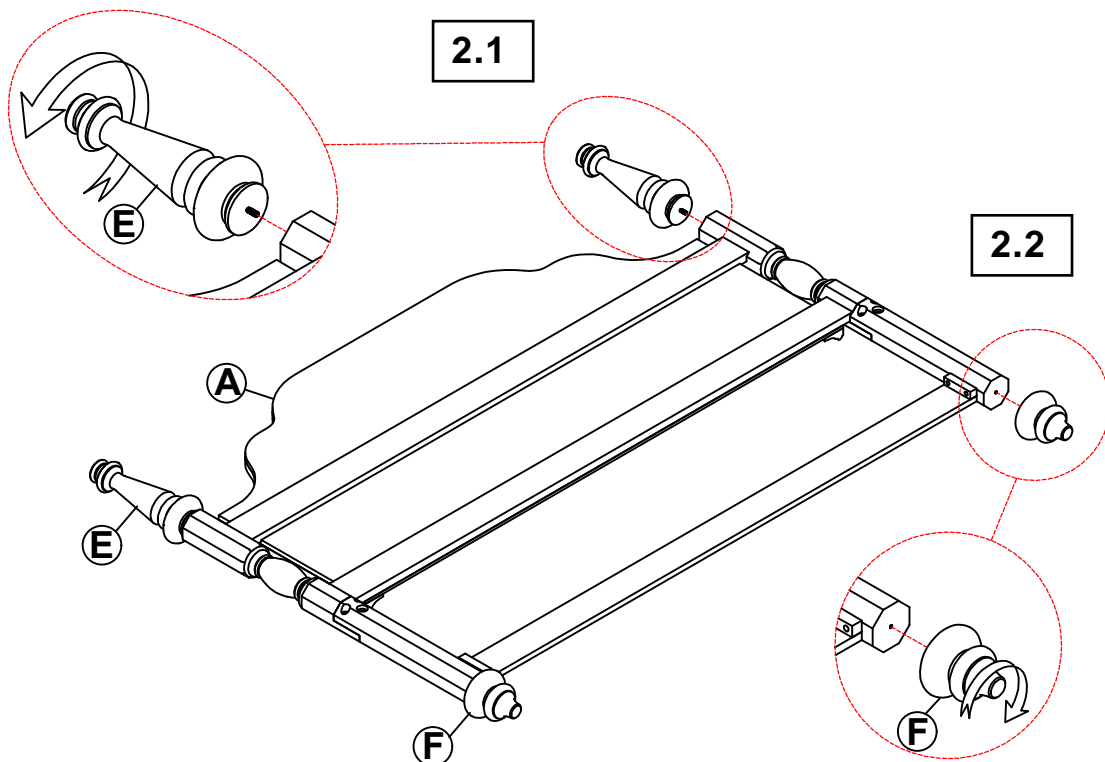

# ITEM: 223631KW(B1-B3)



## ASSEMBLY INSTRUCTIONS

### STEP 3

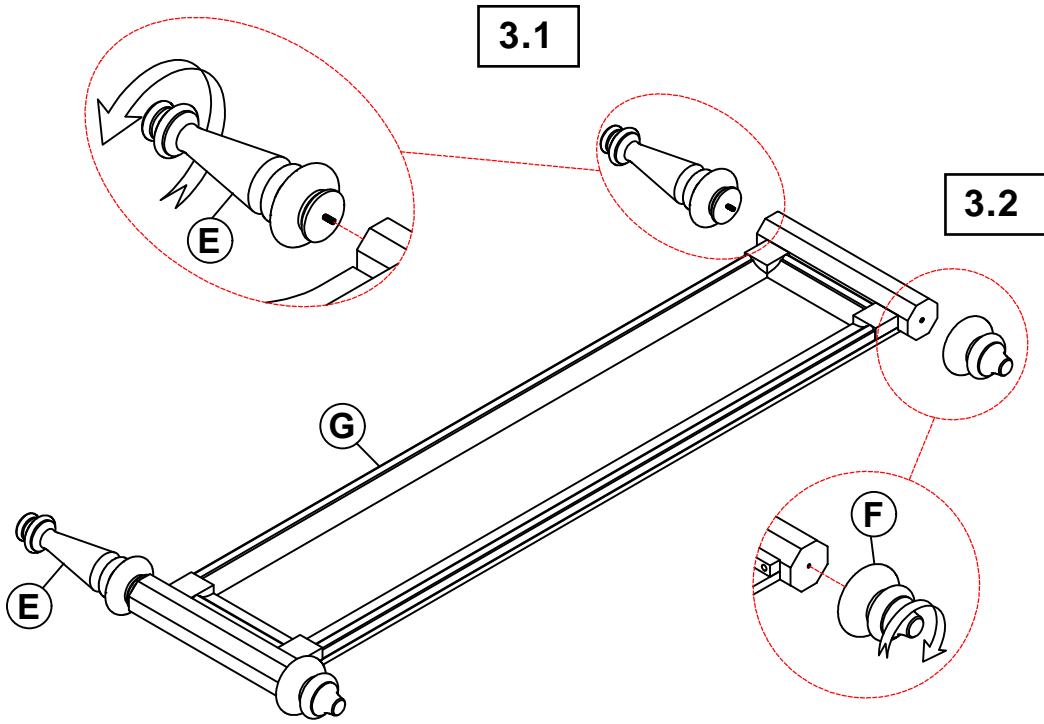

### STEP 4

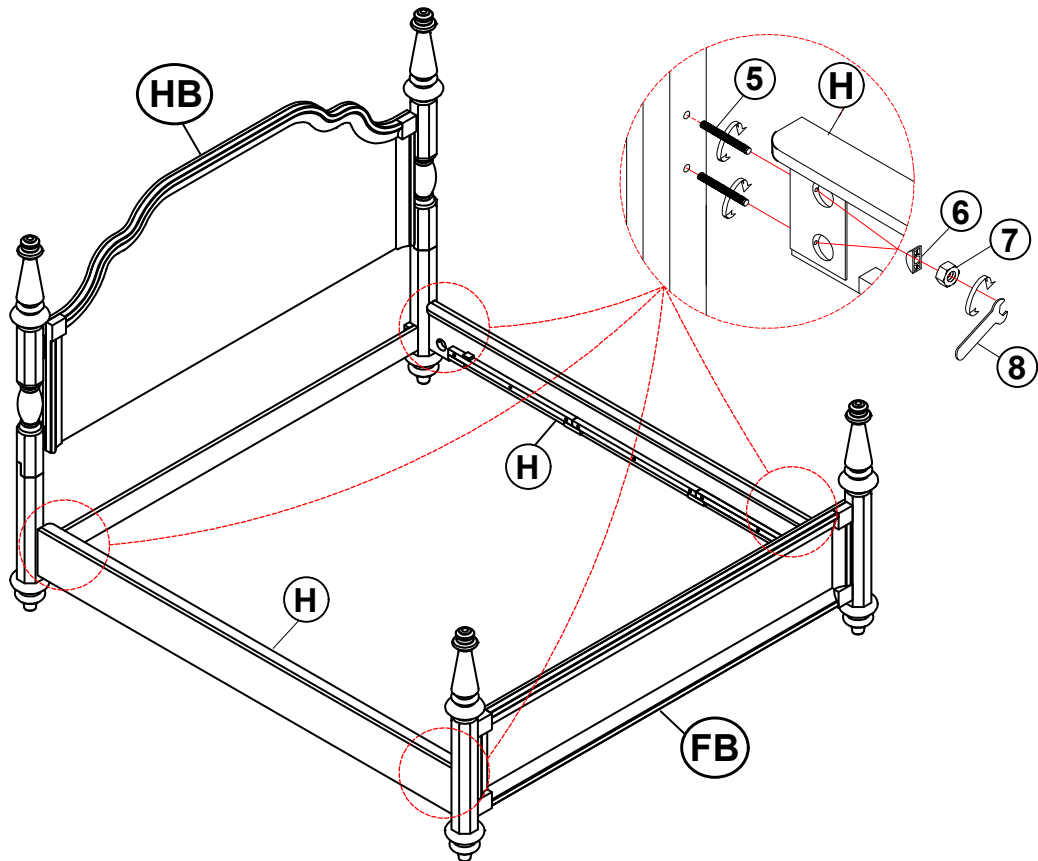

ITEM: **223631KW(B1-B3)**



**ASSEMBLY INSTRUCTIONS**

**STEP 5**

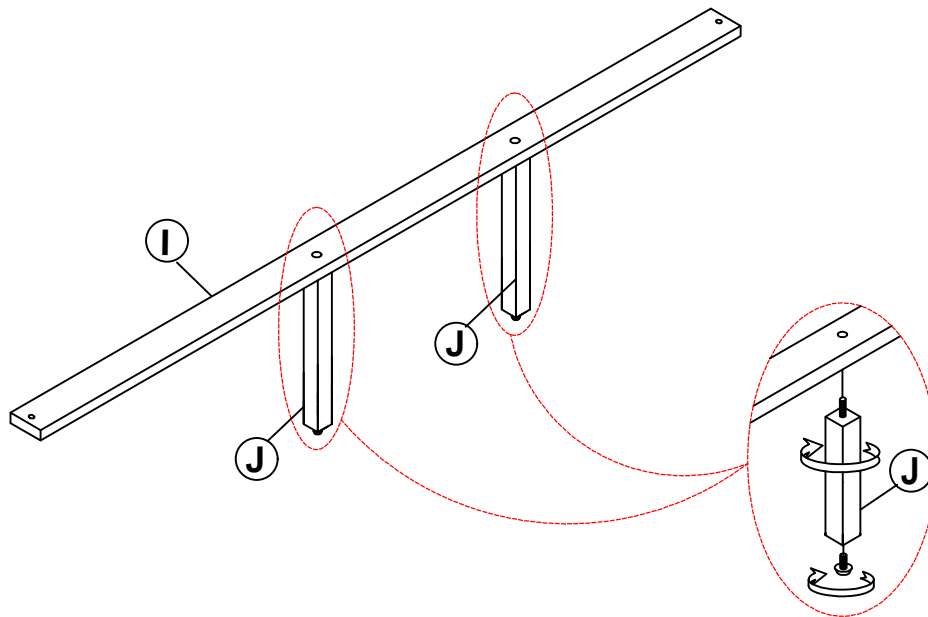

**STEP 6**

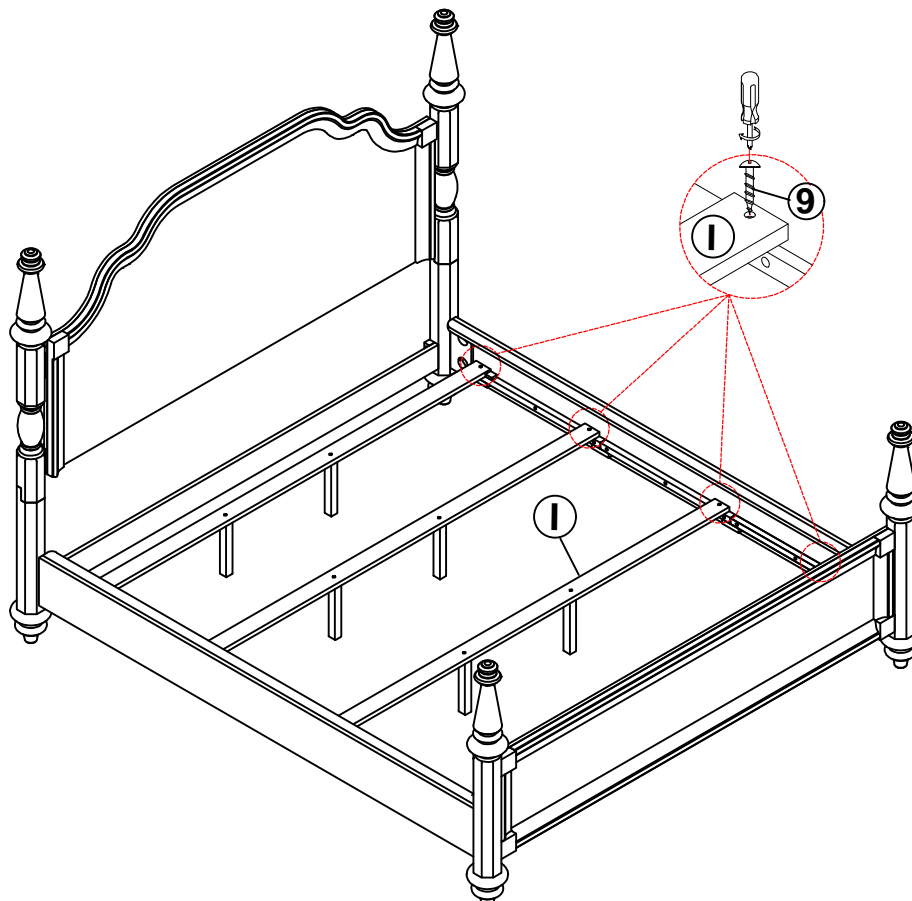

ITEM: **223631KW(B1-B3)**



**ASSEMBLY INSTRUCTIONS**

**STEP 7**  
**COMPLETE**

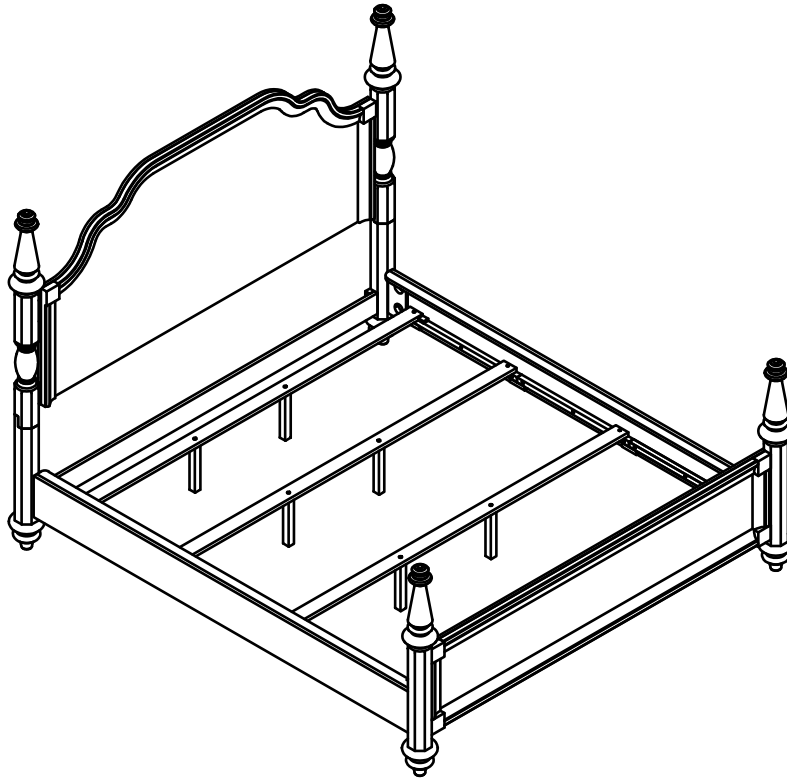

ITEM: **223631KW(B1-B3)**



Inner Size : 82.00"W X 73.00"D

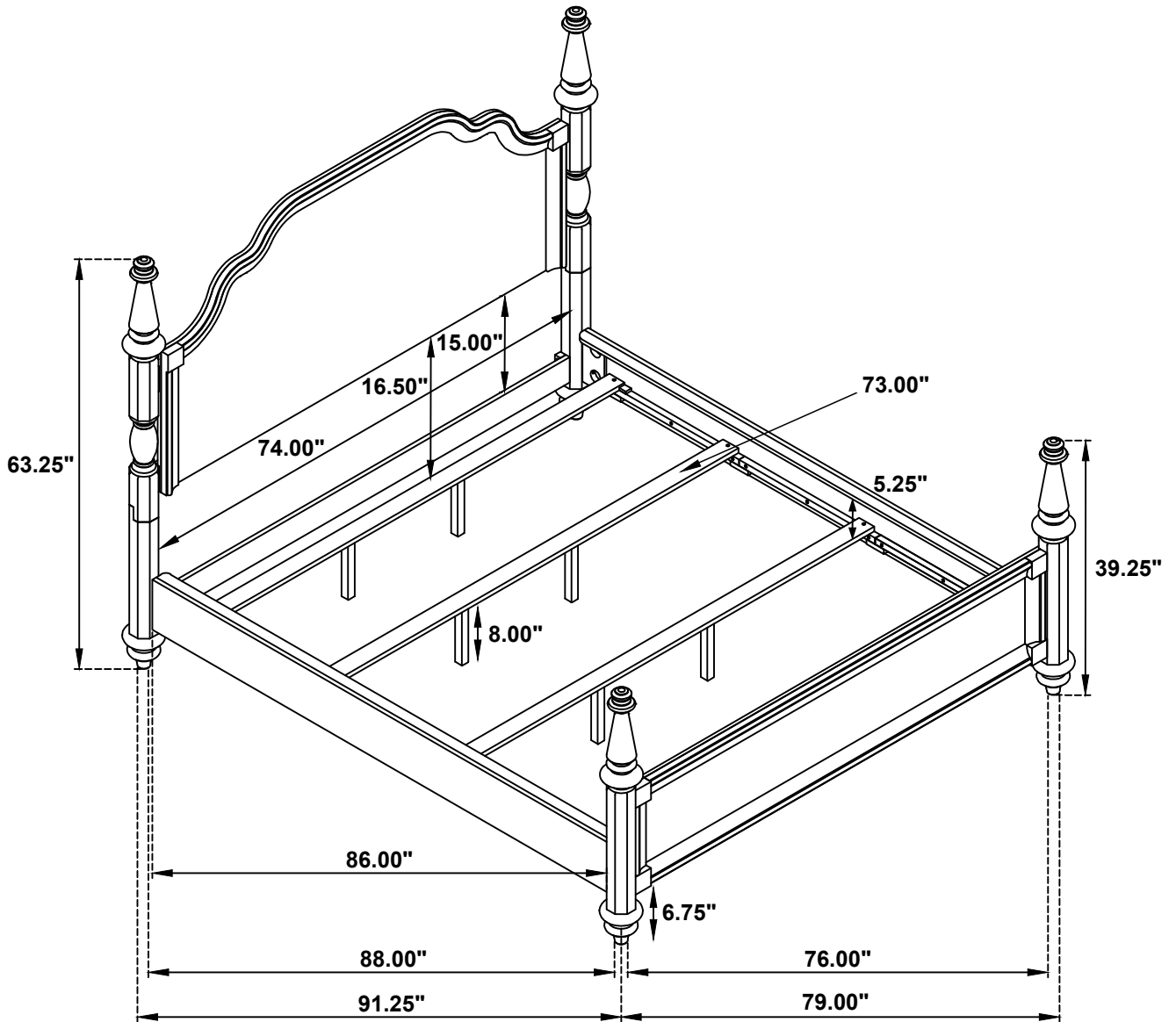

Note: Dimension tolerance  $\pm 5\%$