

ASSEMBLY INSTRUCTIONS
COASTER FINE FURNITURE



Fine Furniture for every stage of life

223631Q (B1-B3)
Queen Bed

ITEM: 223631Q(B1-B3)



ASSEMBLY INSTRUCTIONS

ASSEMBLY TIPS:

1. Remove hardware from box and sort by size.
2. Please check to see that all hardware and parts are present prior to start of assembly.
3. Please follow attached instructions in the same sequence as numbered to assure fast & easy assembly.



WARNING!

1. Don't attempt to repair or modify parts that are broken or defective. Please contact the store immediately.
2. This product is for home use only and not intended for commercial establishments.







ASSEMBLY TIME

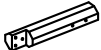
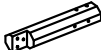

30 MINUTES

PARTS IDENTIFICATION



B1 (BOX 1)

A	HEADBOARD PANEL		1PC	B	HEADBOARD BOTTOM RAIL		1PC
C	RIGHT HEADBOARD LEG		1PC	D	LEFT HEADBOARD LEG		1PC
E	FINIAL		2PCS	F	BUN FOOT		2PCS

B2 (BOX 2)

E	FINIAL		2PCS	F	BUN FOOT		2PCS
G	FOOTBOARD PANEL		1PC				

B3 (BOX 3)

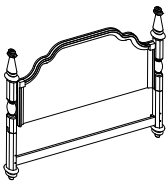
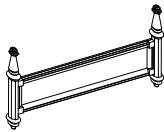
H	BED RAIL		2PCS	I	BED SLAT		4PCS
J	BED SLAT SUPPORT WITH LEVELER		4PCS				
HB	223631Q(B1) FROM BOX 1 HEADBOARD COMPLETE		1PC	FB	223631Q(B2) FROM BOX 2 FOOTBOARD COMPLETE		1PC

NOTE:

Phillips head screw driver is required in the assembly process; however, manufacturer does not provide this item.

ITEM: 223631Q(B1-B3)



ASSEMBLY INSTRUCTIONS

ASSEMBLY TIPS:

1. Remove hardware from box and sort by size.
2. Please check to see that all hardware and parts are present prior to start of assembly.
3. Please follow attached instructions in the same sequence as numbered to assure fast & easy assembly.





WARNING!



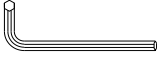

1. Don't attempt to repair or modify parts that are broken or defective. Please contact the store immediately.
2. This product is for home use only and not intended for commercial establishments.

HARDWARE IDENTIFICATION

Z-B1 (BOX 1) - HARDWARE PACK IS LOCATED IN 223631Q(B1)

1	BOLT (\varnothing 5/16" x 50MM - RBW)		10PCS	2	LOCK WASHER (\varnothing 5/16" - RBW)		10PCS
3	FLAT WASHER (\varnothing 5/16" - RBW)		10PCS	4	ALLEN WRENCH (M4 x 60MM - RBW)		1PC

Z-B3 (BOX 3) - HARDWARE PACK IS LOCATED IN 223631Q(B3)

5	THREADED BOLT (\varnothing 5/16" x 90MM - RBW)		8PCS	6	HALF ROUND NUT (\varnothing 5/16" - RBW)		8PCS
7	HEX NUT (\varnothing 5/16" x 14MM - RBW)		8PCS	8	WRENCH (14MM - RBW)		1PC
9	FLAT HEAD SCREW (\varnothing 4 x 30MM - RBW)		8PCS				

NOTE:

Phillips head screw driver is required in the assembly process; however, manufacturer does not provide this item.

ITEM: 223631Q(B1-B3)

ASSEMBLY INSTRUCTIONS

STEP 1

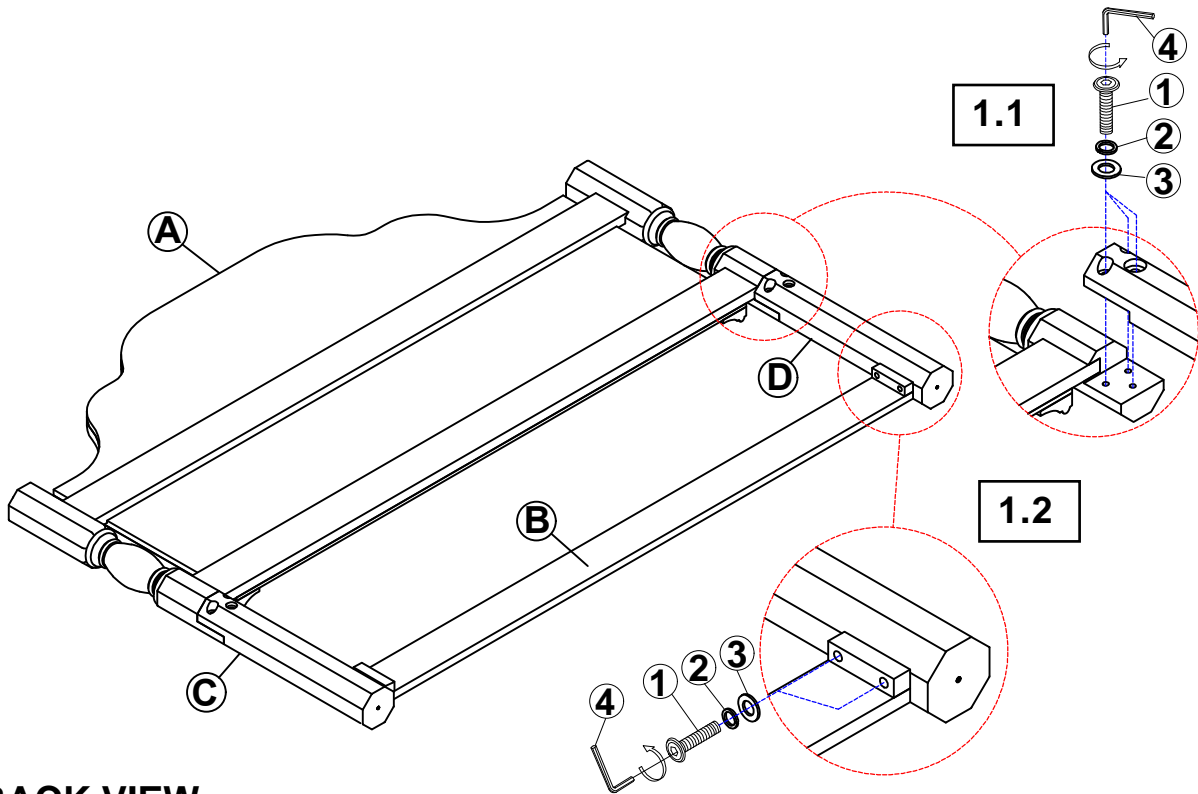

* BACK VIEW

STEP 2

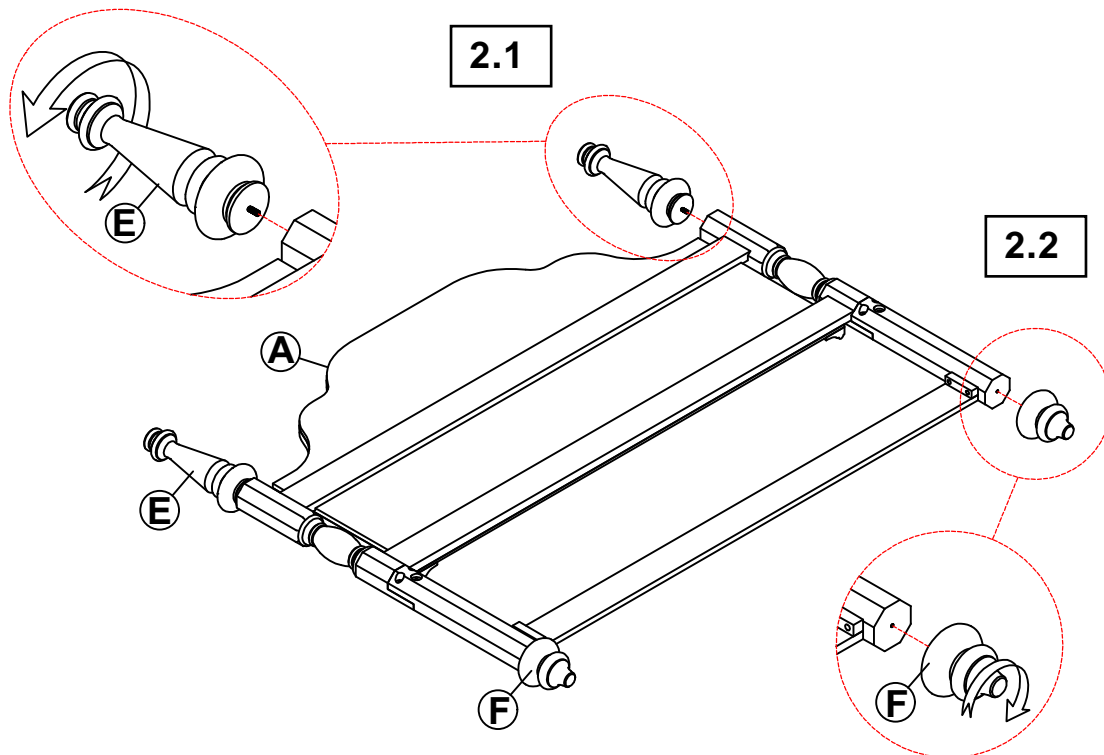

ITEM: 223631Q(B1-B3)

ASSEMBLY INSTRUCTIONS



STEP 3

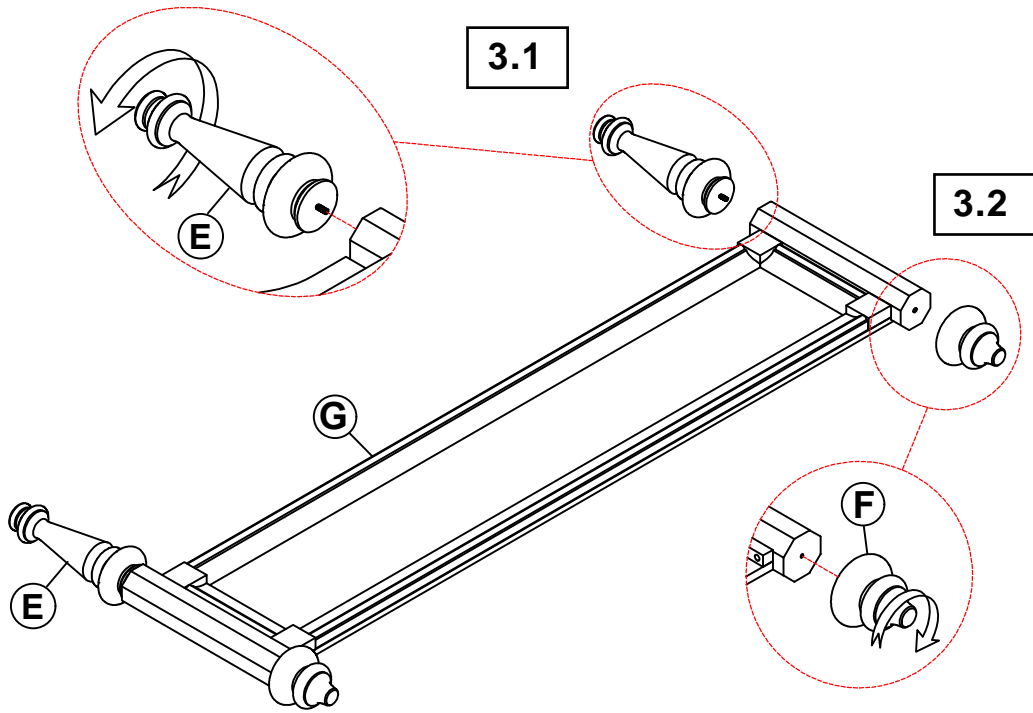

STEP 4

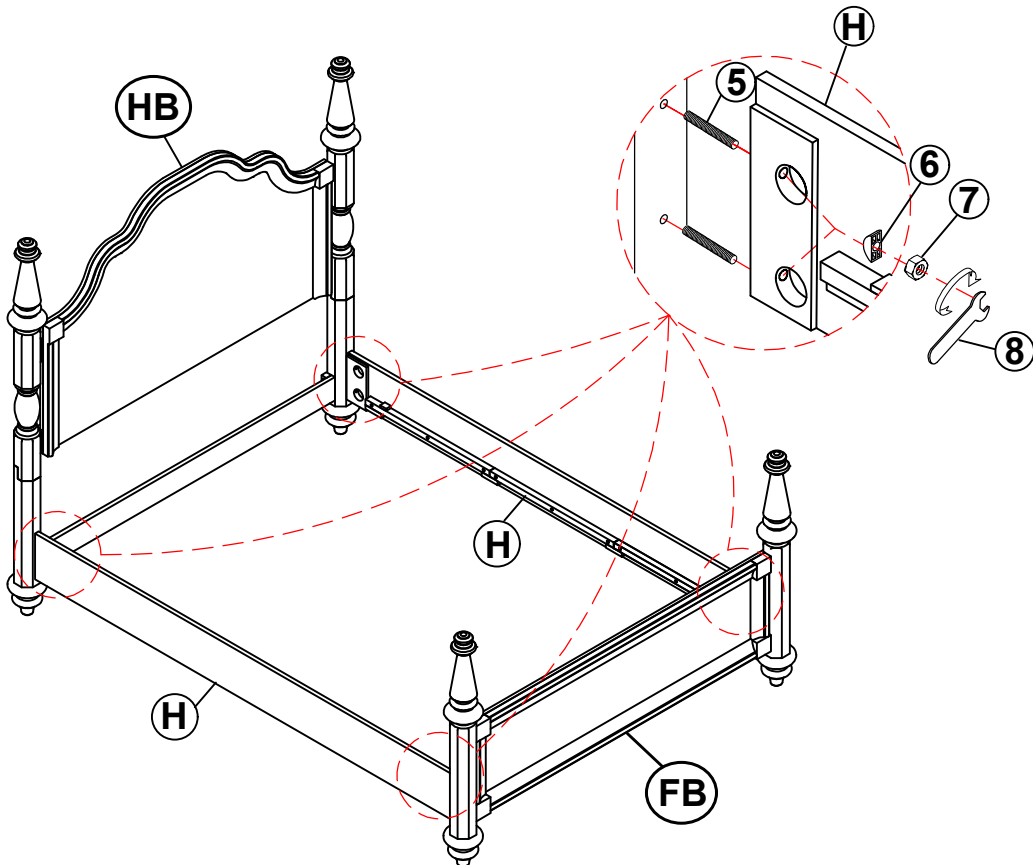

ITEM: 223631Q(B1-B3)

ASSEMBLY INSTRUCTIONS

STEP 5

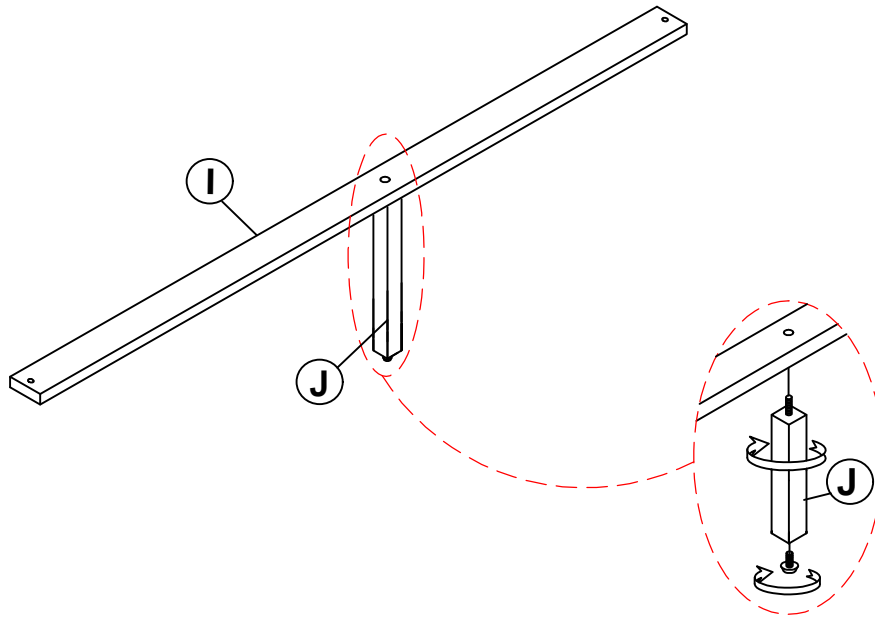

STEP 6

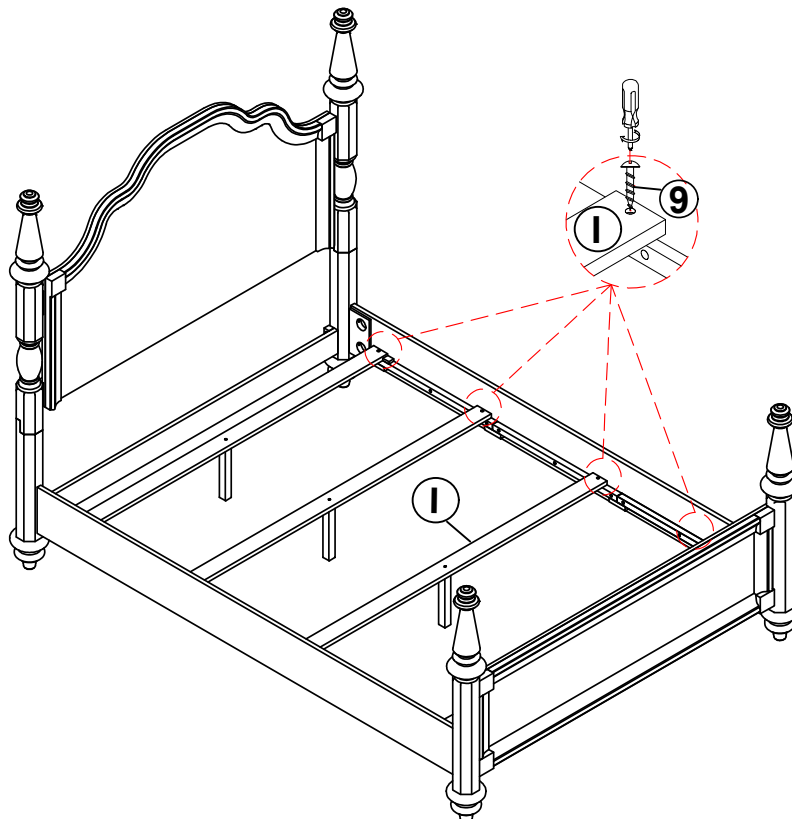

ITEM: **223631Q(B1-B3)**

ASSEMBLY INSTRUCTIONS

STEP 7
COMPLETE

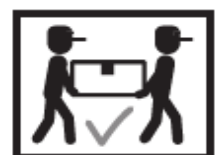
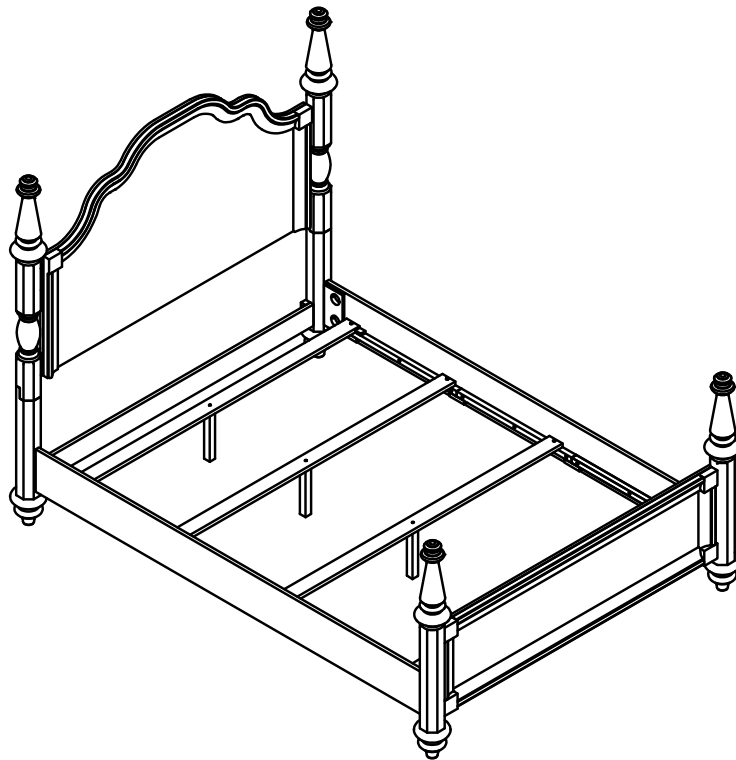

ITEM: 223631Q(B1-B3)



Inner Size : 82.00"W X 61.00"D

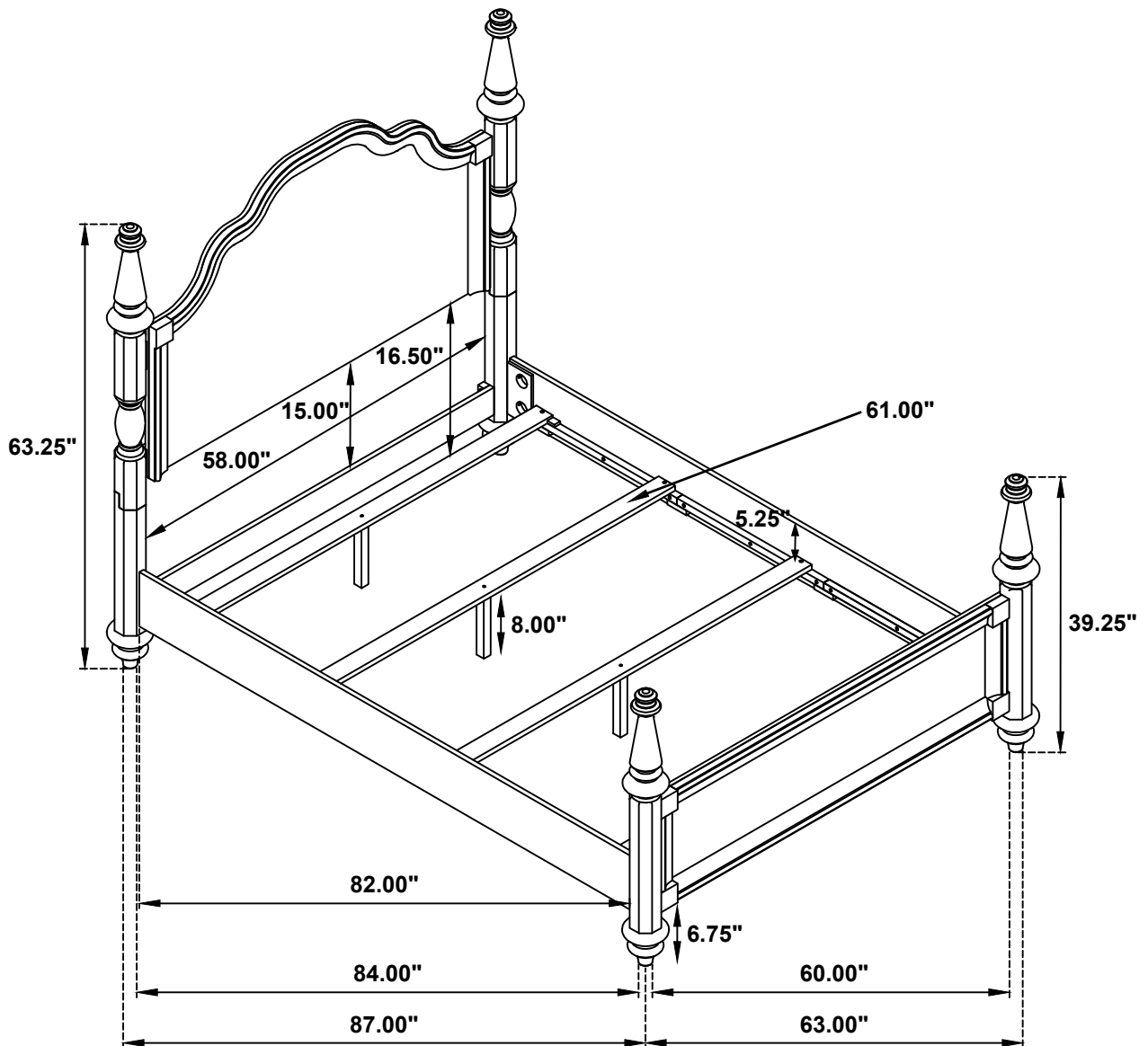

Note: Dimension tolerance $\pm 5\%$