

ASSEMBLY INSTRUCTIONS
COASTER FINE FURNITURE



Fine Furniture for every stage of life

700882
MEDIA TOWER

ITEM: 700882



ASSEMBLY INSTRUCTIONS

ASSEMBLY TIPS:

1. Remove hardware from box and sort by size.
2. Please check to see that all hardware and parts are present prior to start of assembly.
3. Please follow attached instructions in the same sequence as numbered to assure fast & easy assembly.



WARNING!

1. Don't attempt to repair or modify parts that are broken or defective. Please contact the store immediately.
2. This product is for home use only and not intended for commercial establishments.



ASSEMBLY TIME

60 MINUTES

PARTS IDENTIFICATION











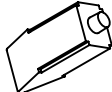

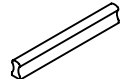
A	LEFT SIDE PANEL		1 PC	H	LOWER BACK PANEL		1 PC
B	RIGHT SIDE PANEL		1 PC	I	DRAWER FRONT PANEL		2 PCS
C	BOTTOM PANEL		1 PC	J	DRAWER BACK PANEL		2 PCS
D	FIXED SHELF		2 PCS	K	DRAWER LEFT SIDE PANEL		2 PCS
E	TOP PANEL		1 PC	L	DRAWER RIGHT SIDE PANEL		2 PCS
F	ADJUSTABLE SHELF		2 PCS	M	DRAWER BOTTOM PANEL		2 PCS
G	UPPER BACK PANEL		1 PC	NN	MIDDLE BACK PANEL		1 PC

NOTE:

Phillips head screw driver is required in the assembly process; however, manufacturer does not provide this item.

ITEM: 700882

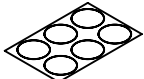
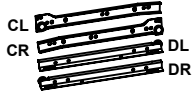
HARDWARE IDENTIFICATION

Z							
NO	DESCRIPTION	FIGURE	Q'TY	NO	DESCRIPTION	FIGURE	Q'TY
1	GLUE 40g		1 PC	9	PIN Ø 4.9x8mm		8 PCS
2	WOODEN DOWEL Ø 8x30mm		24 PCS	10	HANDLE L=120mm		2 PCS
3	CAM BOLT Ø 7x35.5mm		16 PCS	11	HANDLE BOLT Ø 4x28mm		4 PCS
4	CAM LOCK Ø 15x12mm		16 PCS	12	FOOT 50x50x70mm		4 PCS
5	BOLT Ø 9.5x55mm FOR BOTTOM PANEL		4 PCS	13	BOLT Ø 6.35x41mm FOR FOOT		4 PCS
6	SCREW Ø 4.3x35mm FOR DRAWER		8 PCS	14	STICKER Ø 20mm		3 PCS
7	RAIL L = 250mm		2 SET	15	PLASTIC COVER Ø 52mm		1 PC
8	SCREW FOR RAIL Ø 3x12mm		20 PCS				

Z7,Z10,Z11,Z12 not included in blister packaging.

NOTE:

Phillips head screw driver is required in the assembly process; however, manufacturer does not provide this item.

ITEM: 700882

STEP 1

- 2 x 16
- 3 x 12
- 7 (CL) x 2
- 8 x 12
- 12 x 4
- 13 x 4
- 15 x 1

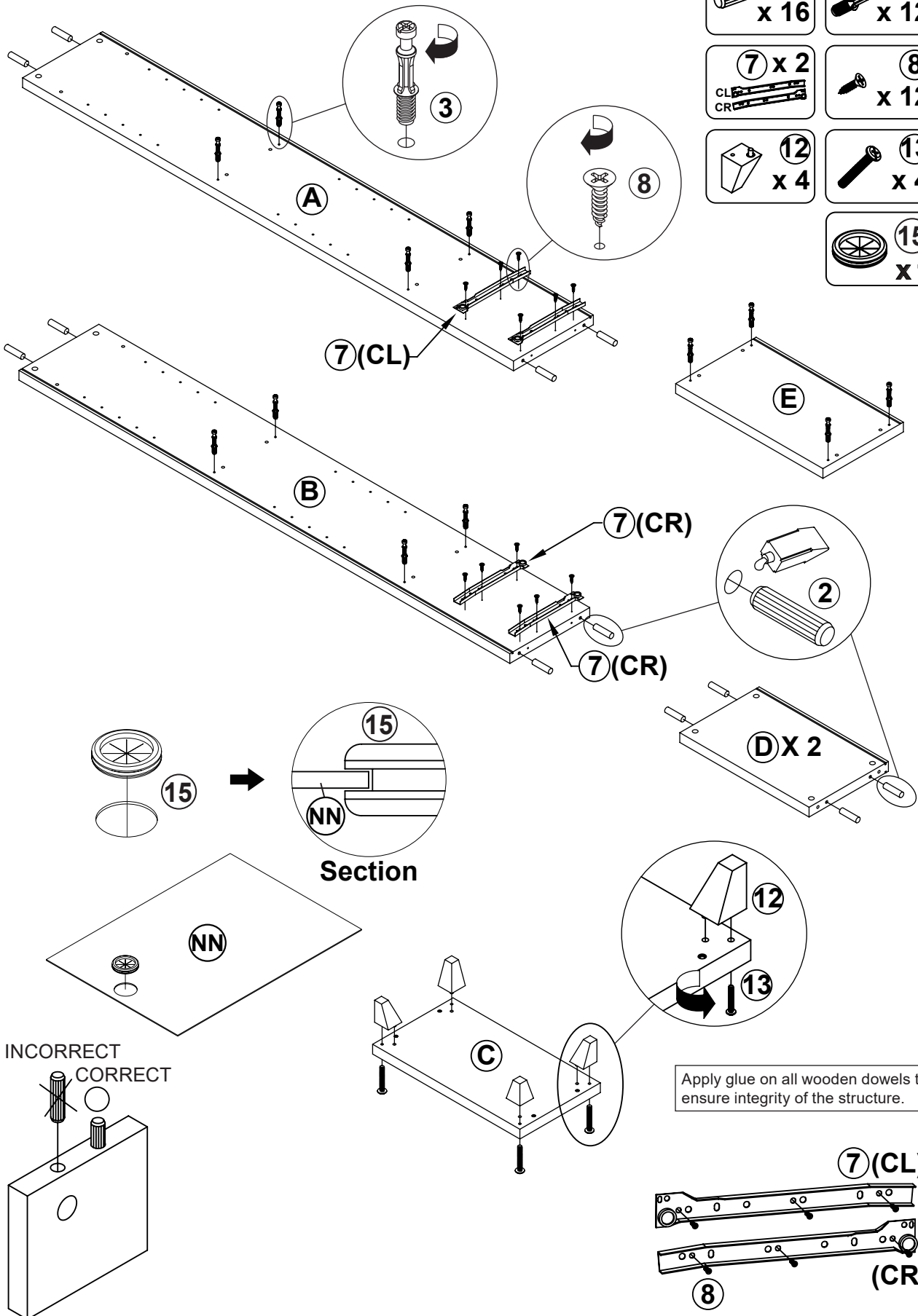

ITEM: 700882

STEP 2

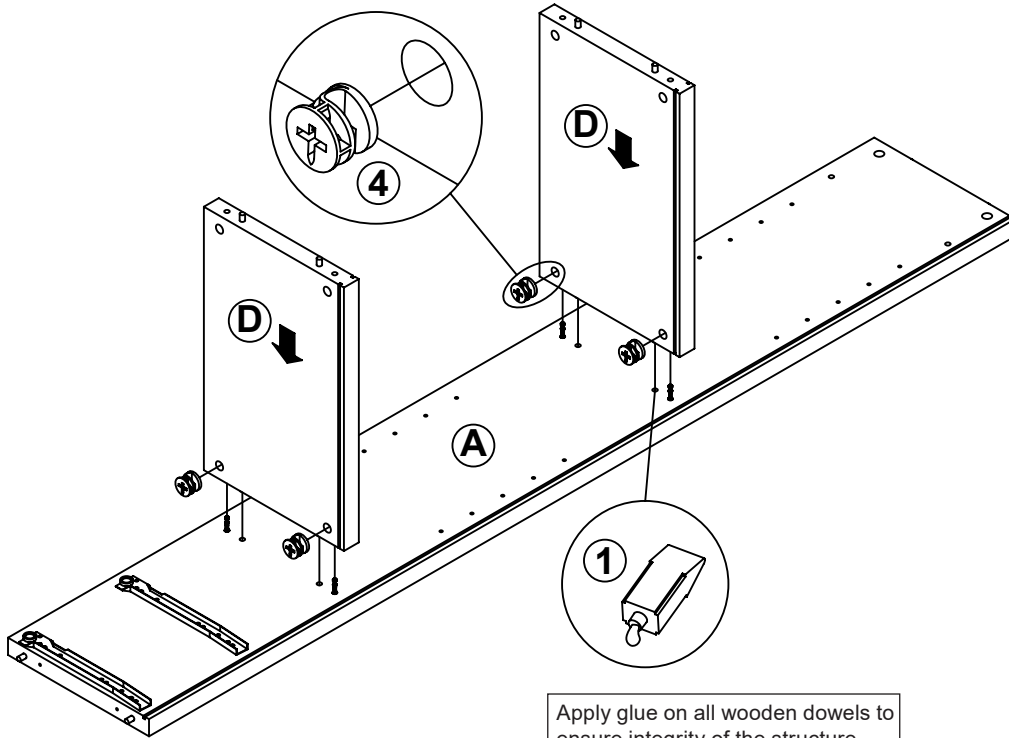
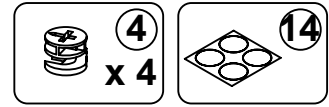

Apply glue on all wooden dowels to ensure integrity of the structure.

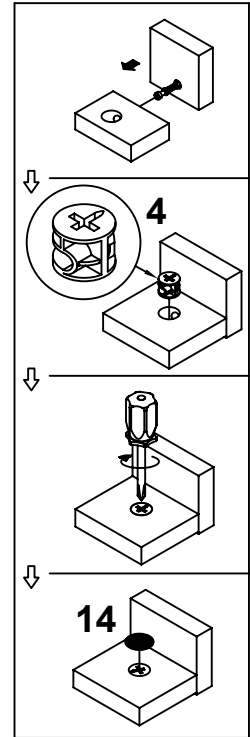

STEP 3

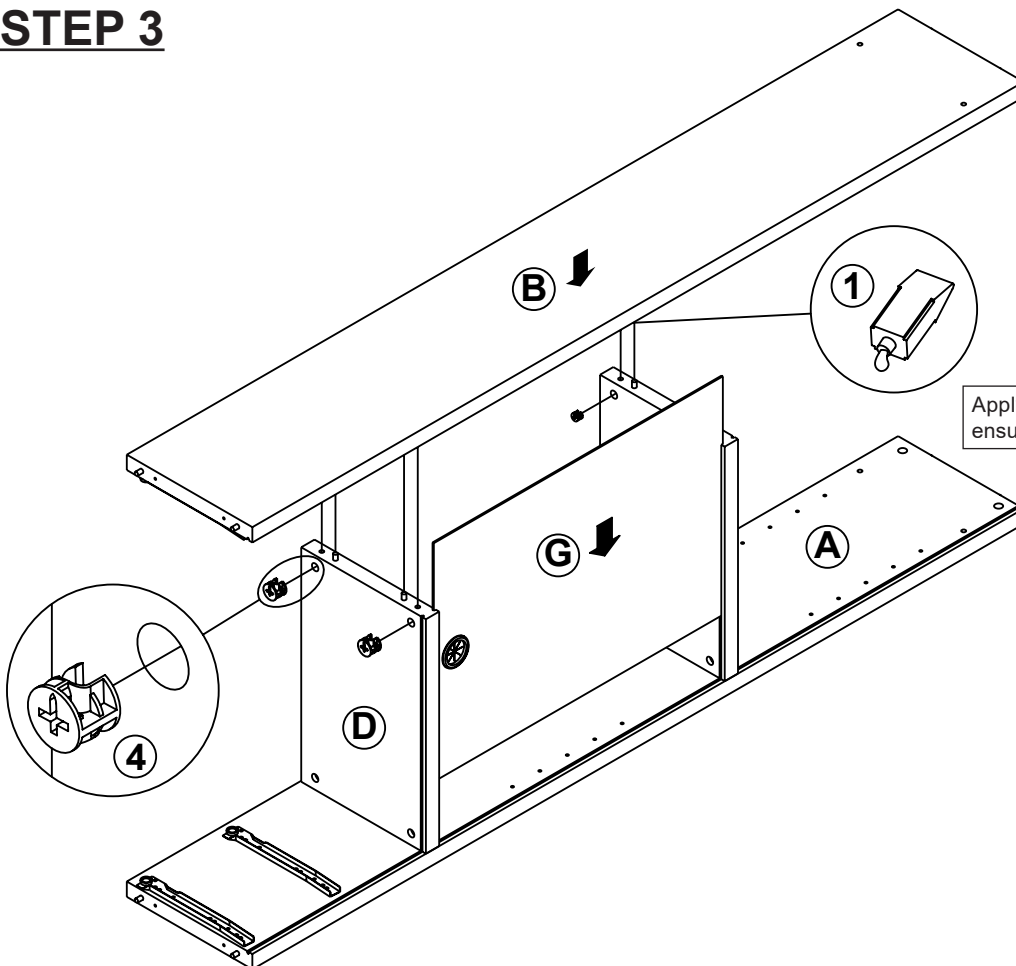
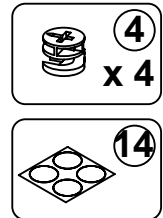

Apply glue on all wooden dowels to ensure integrity of the structure.

ITEM: 700882

STEP 4

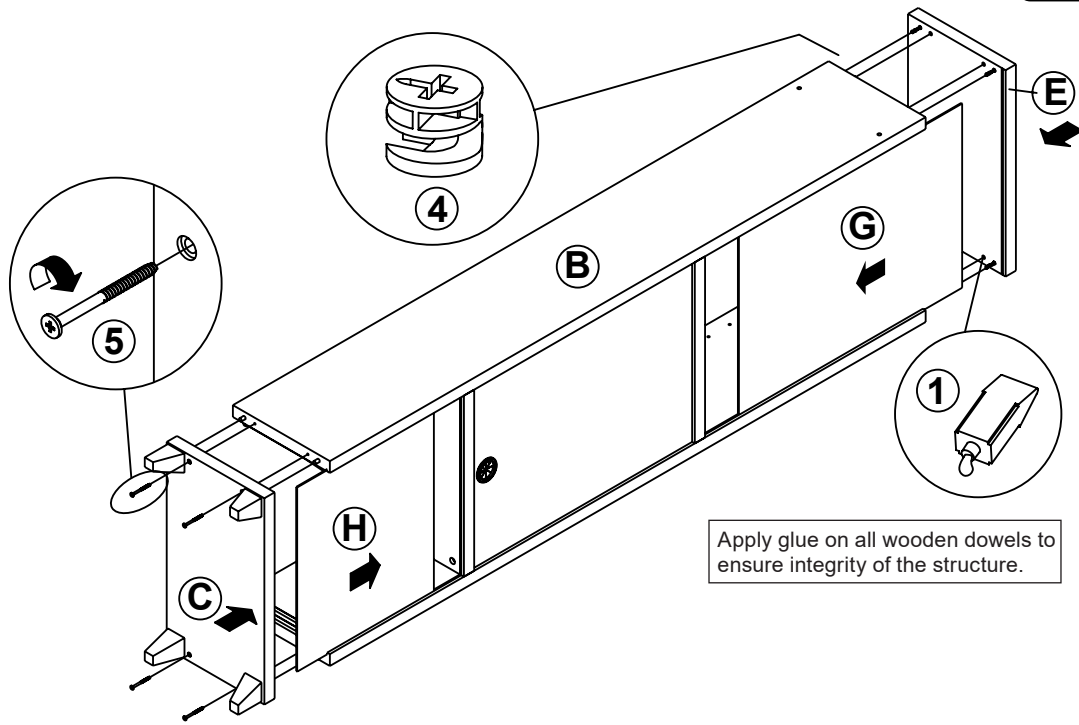
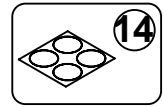
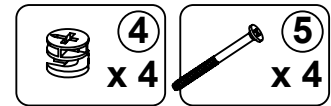

Apply glue on all wooden dowels to ensure integrity of the structure.

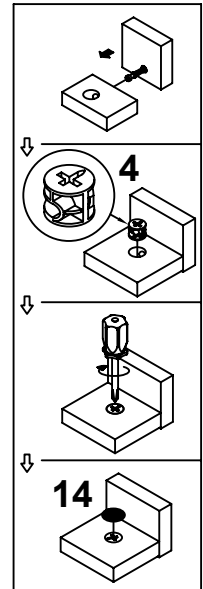

STEP 5

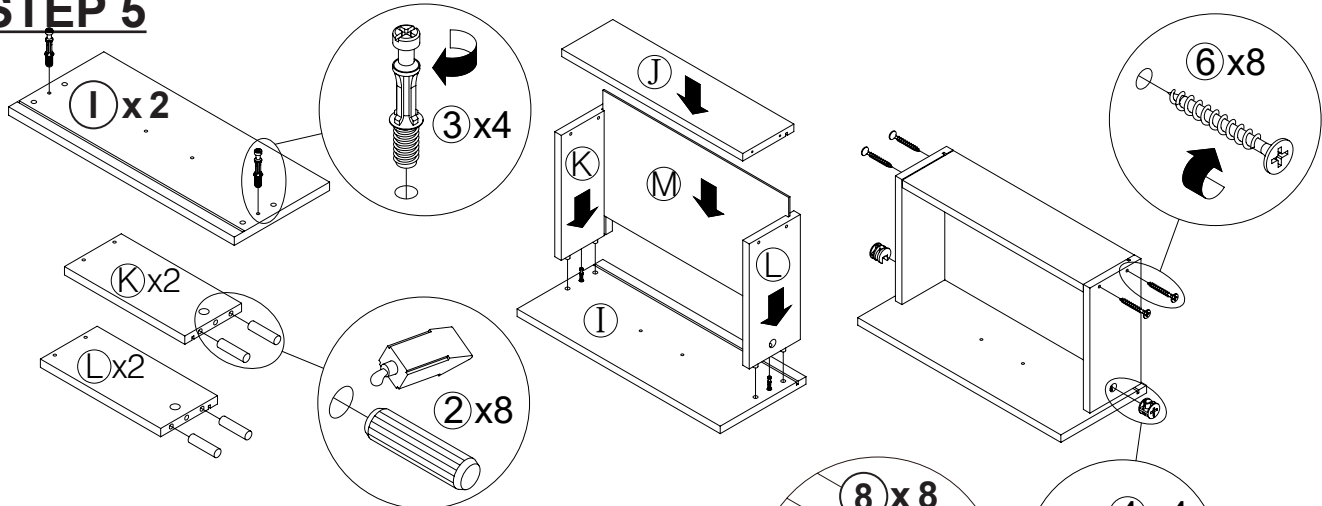

Apply glue on all wooden dowels to ensure integrity of the structure.

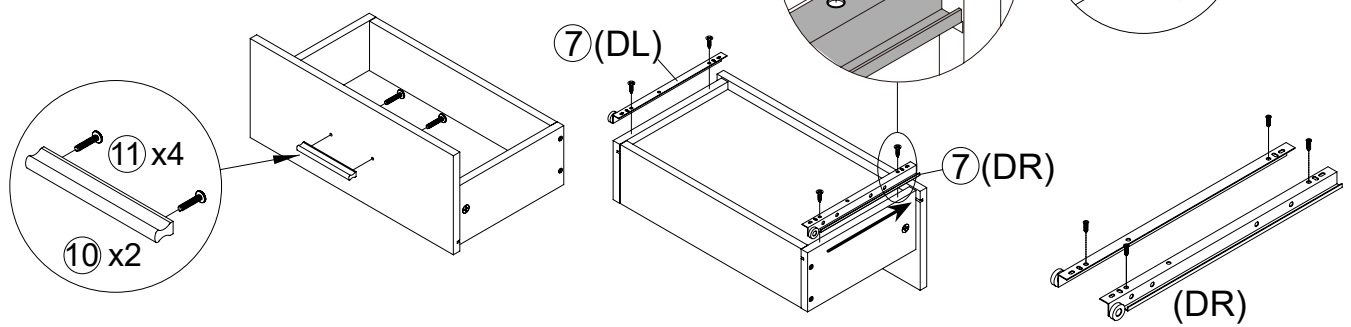

ITEM: 700882

STEP 6

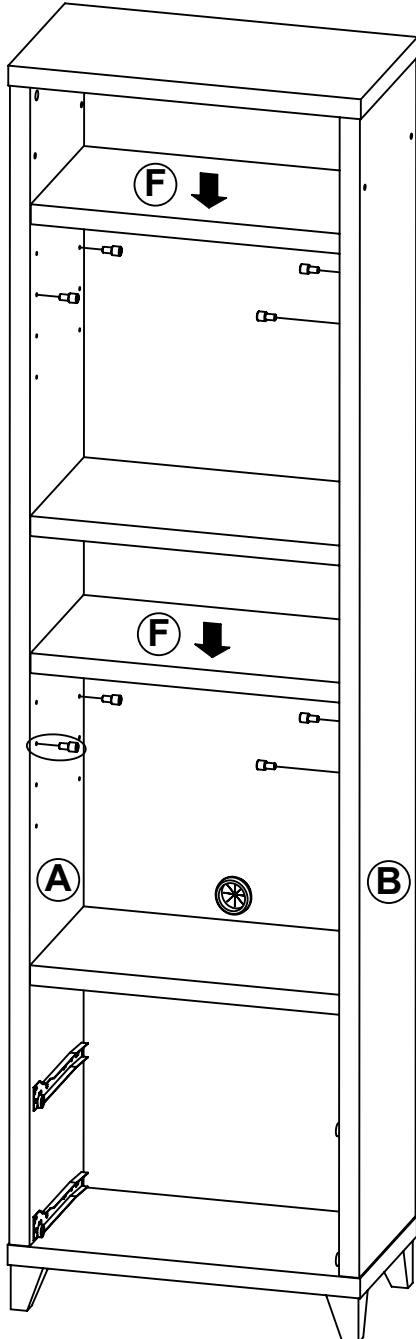
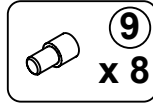

STEP 7

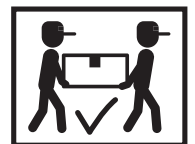
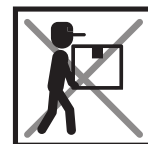
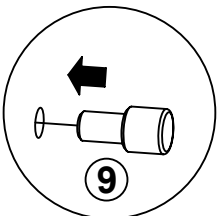
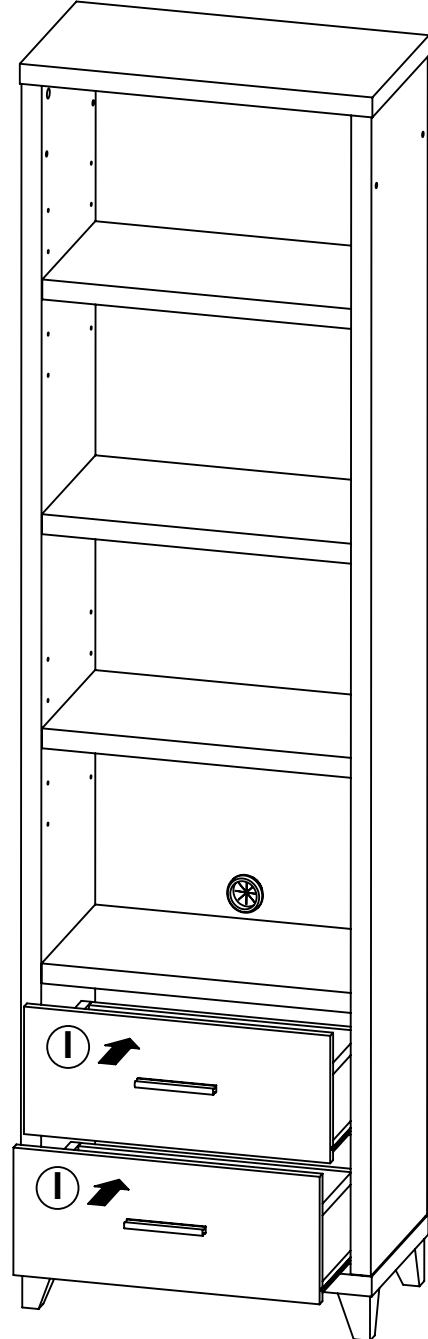

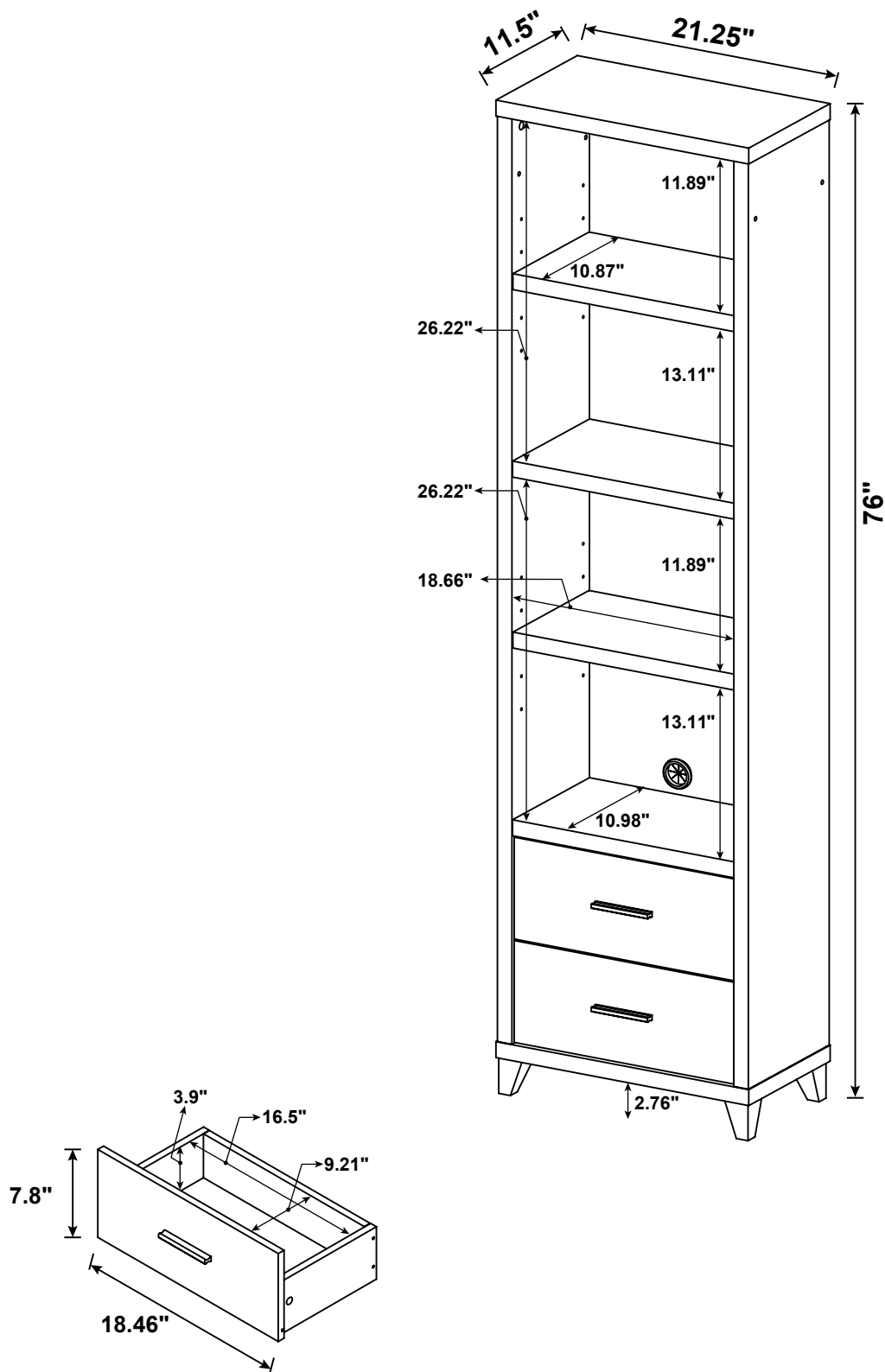

Note : Dimension tolerance $\pm 5\%$

ANTI-TIPPING INSTALLMENT INSTRUCTIONS FURNITURE TIPPING RESTRAINT

WARNING

Injury may result from tipping furniture.
This restraint may protect against tipping furniture.
Do not allow children to climb on furniture.
This restraint is not a substitute for proper adult supervision.
Failure to detach this restraint before moving the furniture may result in injury and damage.

This restraint must be screwed to a wood stud on the wall, using the long screw provided.

STEP 1

Secure the bracket to the back top of the unit, using the short screw provided, as shown in the drawing.

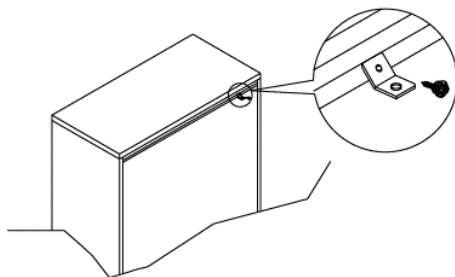

STEP 2

Locate the wood stud on the wall, and secure the other bracket, 2 inches below the back of the unit.

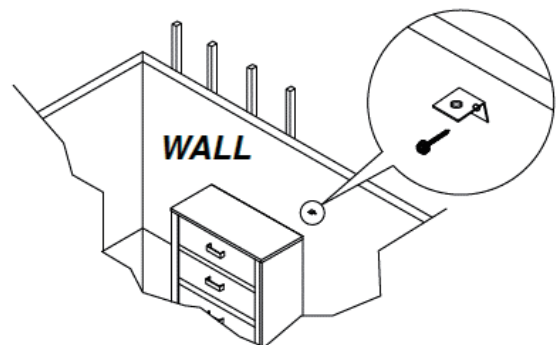

STEP 3

Place the furniture into position so both mounting brackets are vertically in line. Lace the end of the restraint strap through the larger hole in each mounting bracket. Bring both ends together and slide the flat end through the locking end, and drag it through, until the slack is removed. Ensure that the strap is securely laced and locked.

