

ASSEMBLY INSTRUCTIONS
COASTER FINE FURNITURE



Fine Furniture for every stage of life

704254
MEDIA TOWER

ITEM: 704254



ASSEMBLY INSTRUCTIONS

ASSEMBLY TIPS:

1. Remove hardware from box and sort by size.
2. Please check to see that all hardware and parts are present prior to start of assembly.
3. Please follow attached instructions in the same sequence as numbered to assure fast & easy assembly.



WARNING!

1. Don't attempt to repair or modify parts that are broken or defective. Please contact the store immediately.
2. This product is for home use only and not intended for commercial establishments.



ASSEMBLY TIME

50 MINUTES









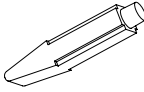
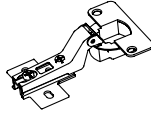
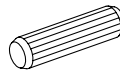

PARTS IDENTIFICATION

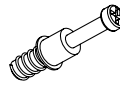
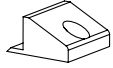
A	LEFT SIDE PANEL		1 PC	F	ADJUSTABLE SHELF		1 PC
B	RIGHT SIDE PANEL		1 PC	G	UPPER BACK PANEL		1 PC
C	BOTTOM PANEL		1 PC	HN	LOWER BACK PANEL		1 PC
D	CROSS PANEL		1 PC	I	DOOR		1 PC
E	TOP PANEL		1 PC	J	GLASS		2 PCS

NOTE:

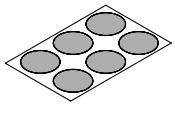
Phillips head screw driver is required in the assembly process; however, manufacturer does not provide this item.

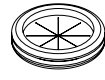
HARDWARE IDENTIFICATION

Z							
NO	DESCRIPTION	FIGURE	Q'TY	NO	DESCRIPTION	FIGURE	Q'TY
1	GLUE 15g		1 PC	8	HINGE Ø35mm SR		2 PCS
2	WOODEN DOWEL Ø8x30mm		12 PCS	9	HINGE SCREW Ø4x15mm SR		8 PCS
3	CAM BOLT Ø7x35.5mm SR		12 PCS	10	FIXER		3 PCS
4	CAM LOCK Ø15x12mm SR		12 PCS	11	FIXER SCREW Ø3x19mm SR		3 PCS
5	PLASTIC FEET Ø15mm		4 PCS	12	STICKER Ø20mm		2 PCS
6	PIN FOR ADJUSTABLE SHELF Ø4.9x15mm SR		4 PCS	13	PLASTIC COVER Ø 52mm		1 PC
7	GLASS PIN Ø5x23mm SR		8 PCS				

Z8 not included in blister packaging.

NOTE:

Phillips head screw driver is required in the assembly process; however, manufacturer does not provide this item.

ITEM: 704254

COASTER[®]

FINE FURNITURE

STEP 1

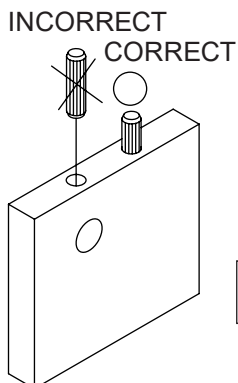
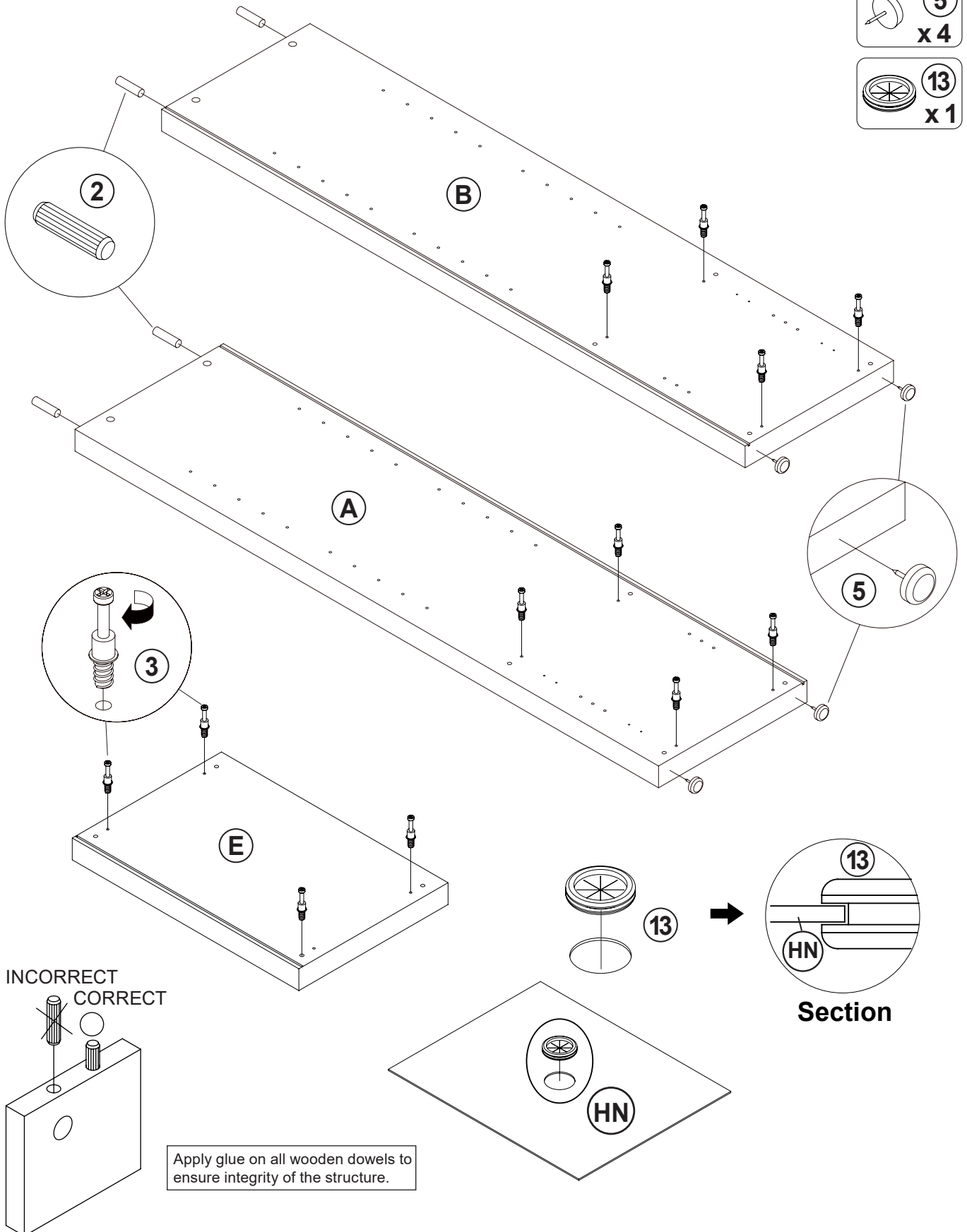
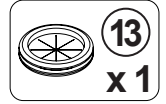
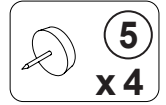
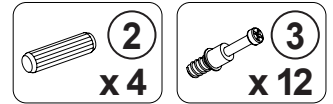

Apply glue on all wooden dowels to ensure integrity of the structure.

ITEM: 704254

STEP 2

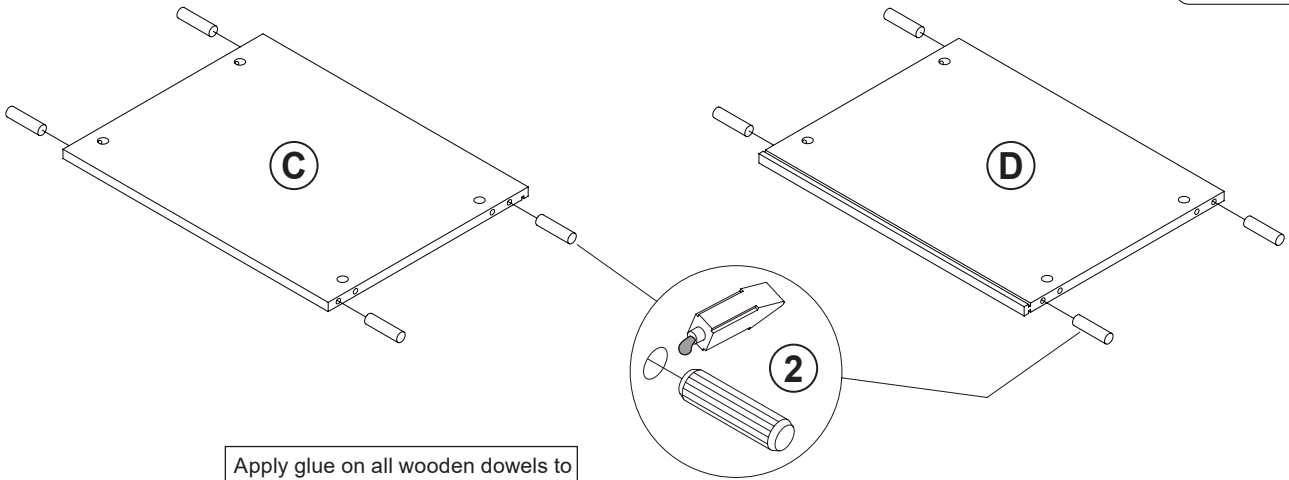
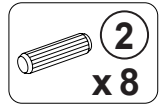

Apply glue on all wooden dowels to ensure integrity of the structure.

STEP 3

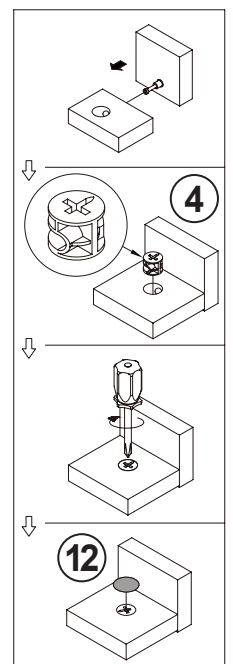
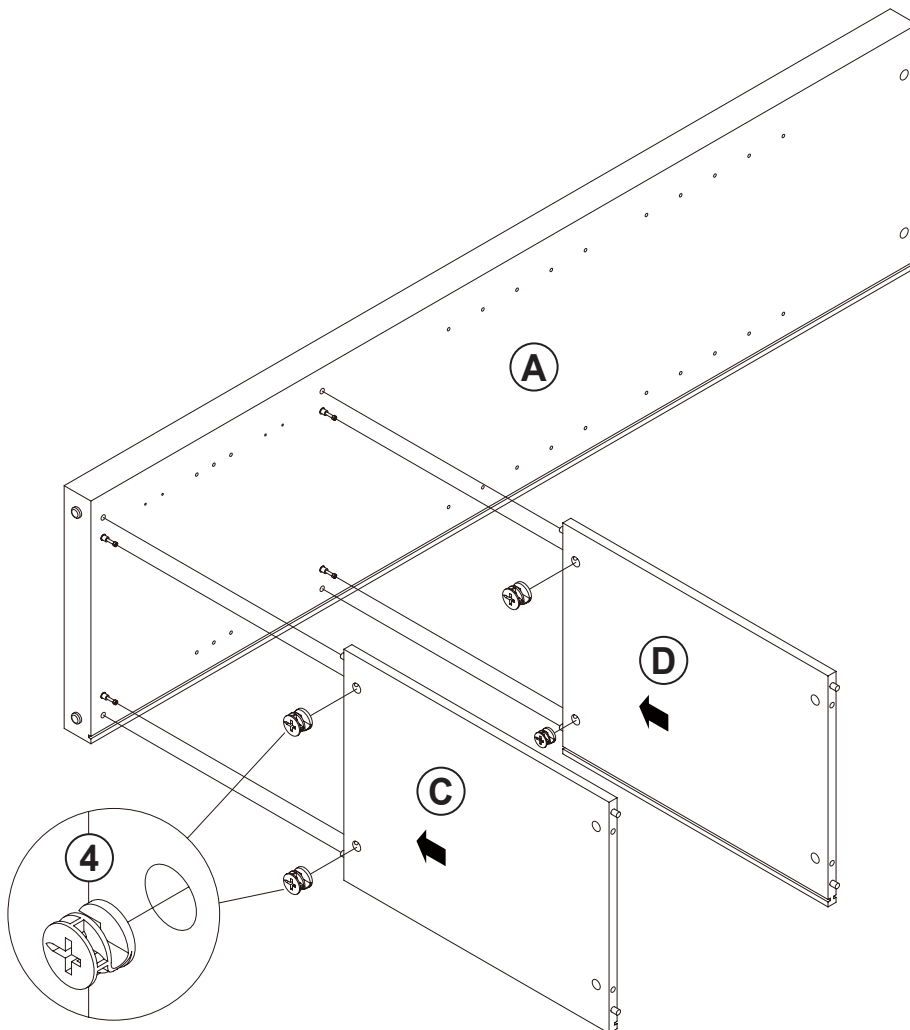
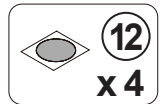

ITEM: 704254

COASTER
FINE FURNITURE

STEP 4

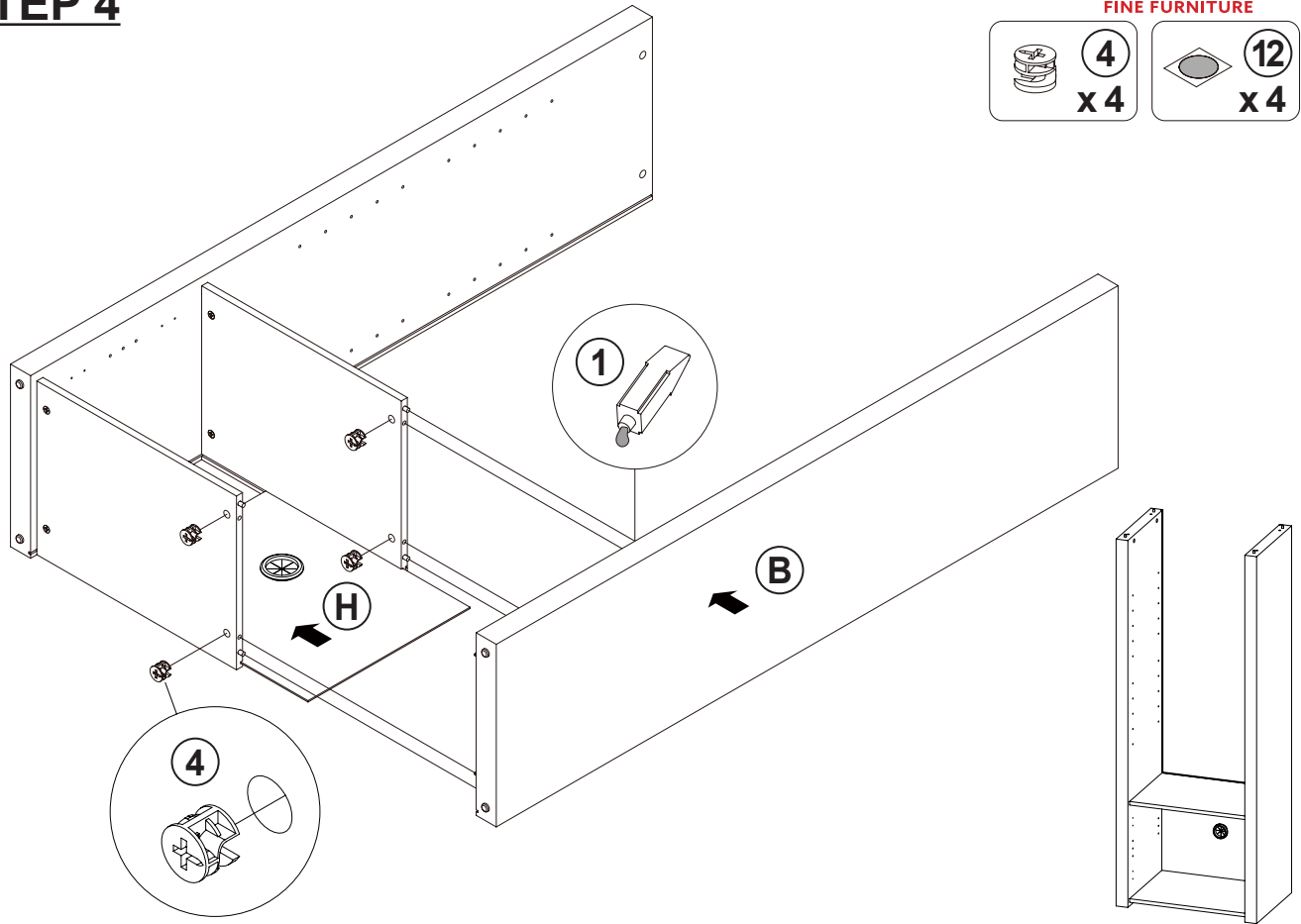
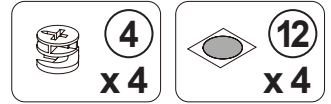

STEP 5

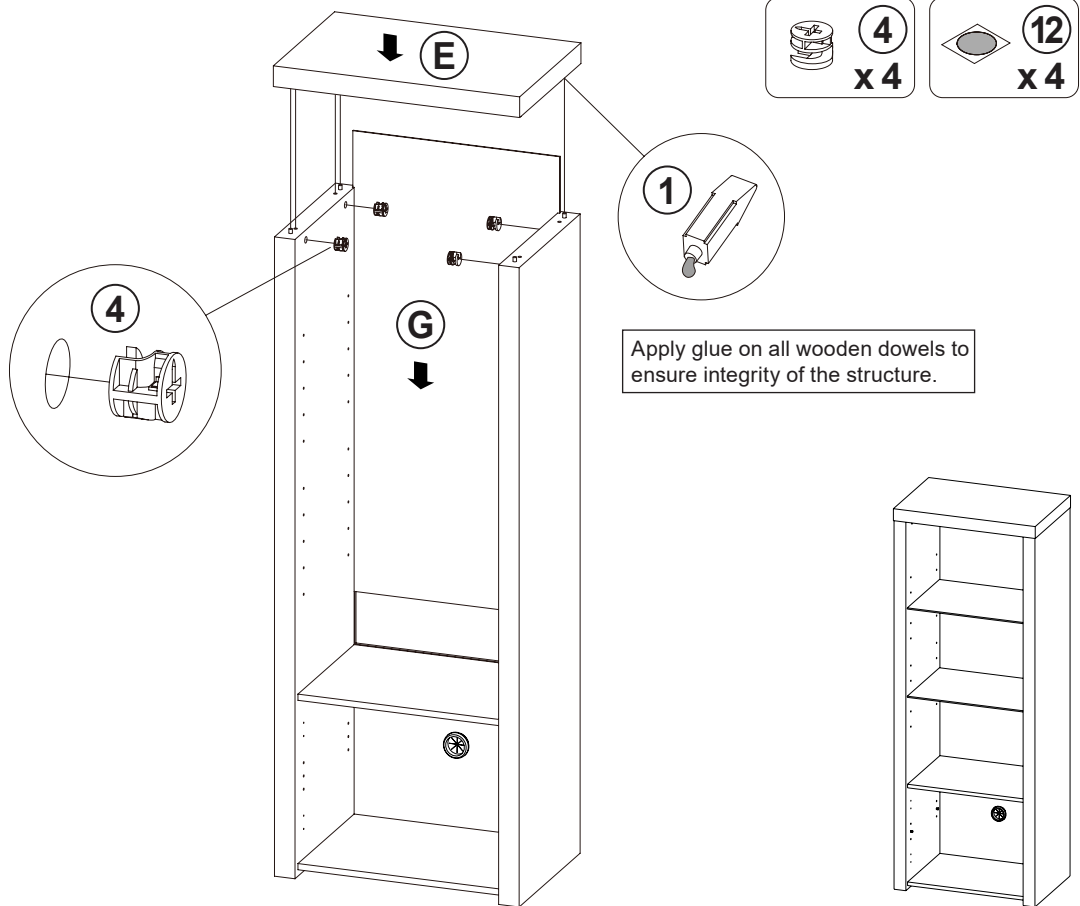
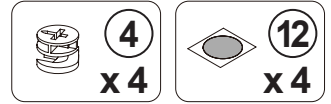

ITEM: 704254

STEP 6

COASTER
FINE FURNITURE

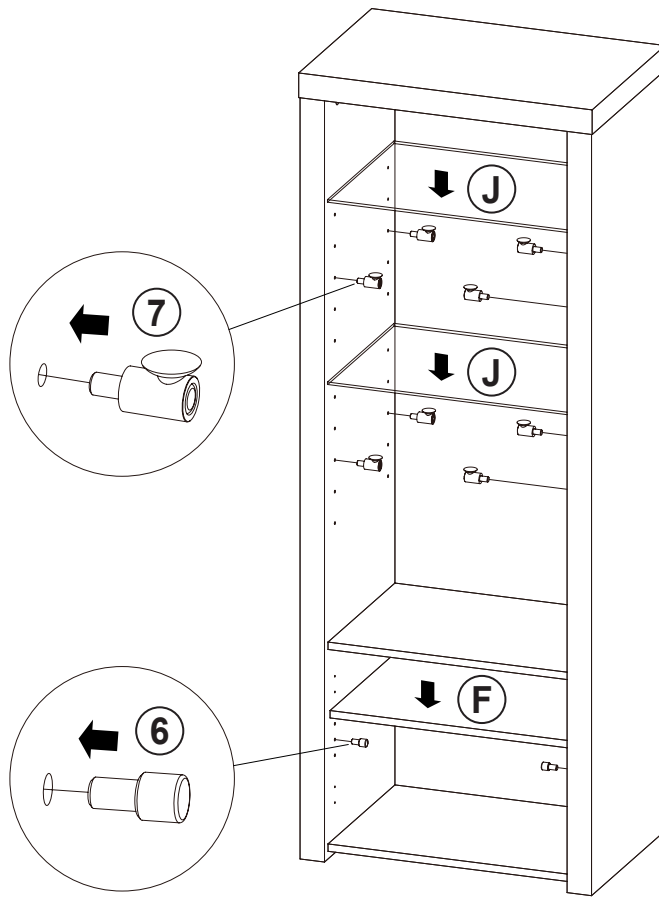
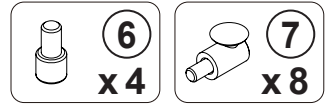

STEP 7

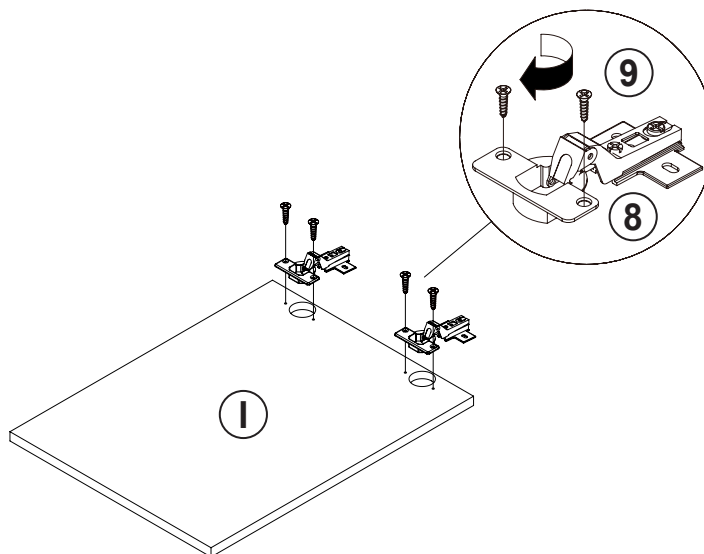
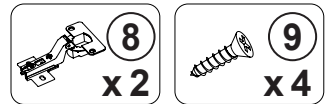

ITEM: 704254

COASTER
FINE FURNITURE

STEP 8

LEFT

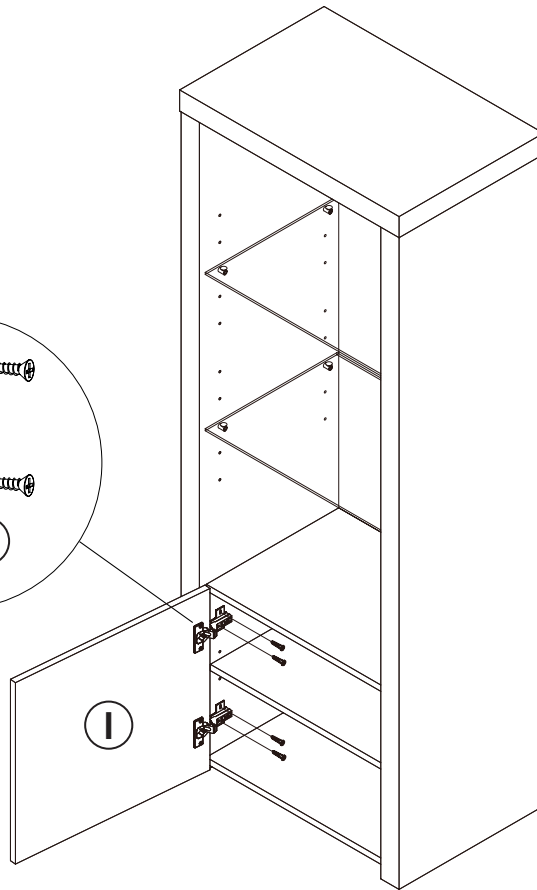
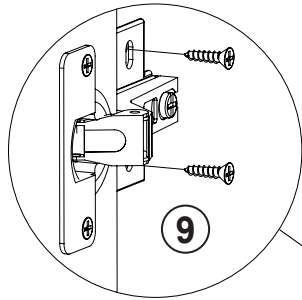
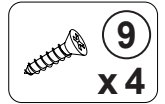

RIGHT

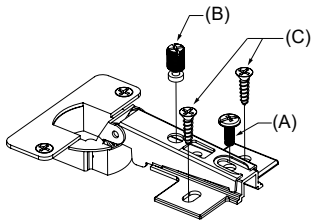

HORIZONTAL BY
SCREW A ADJUSTMENT

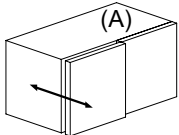

LATERAL BY
SCREW B ADJUSTMENT

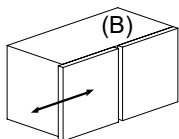

VERTICAL BY
SCREW C ADJUSTMENT

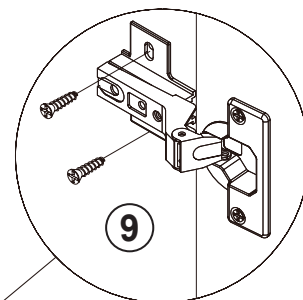
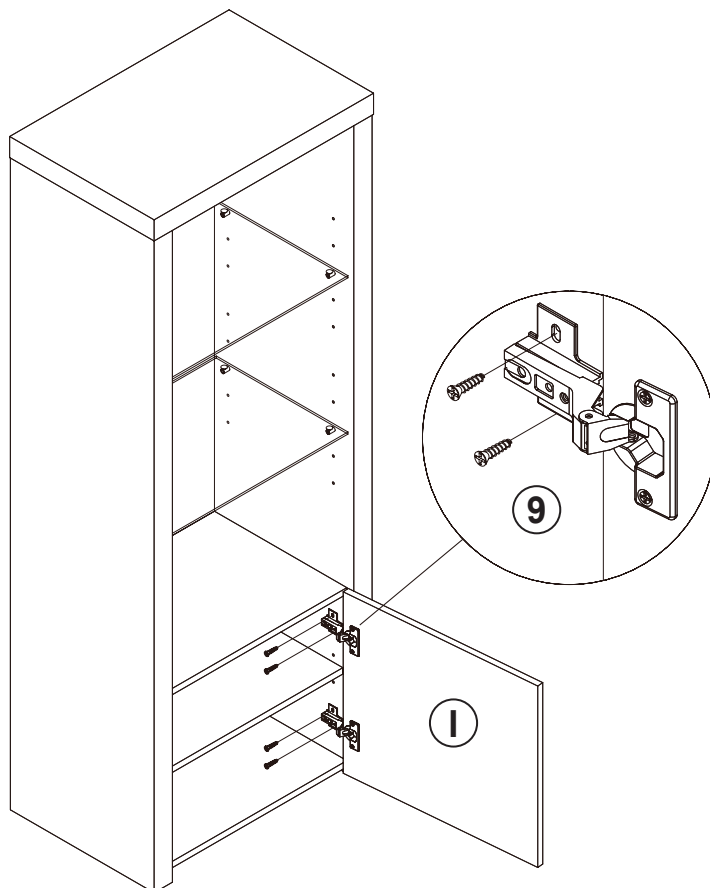
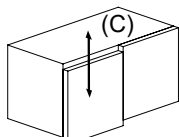

ITEM: 704254

COASTER
FINE FURNITURE

STEP 9

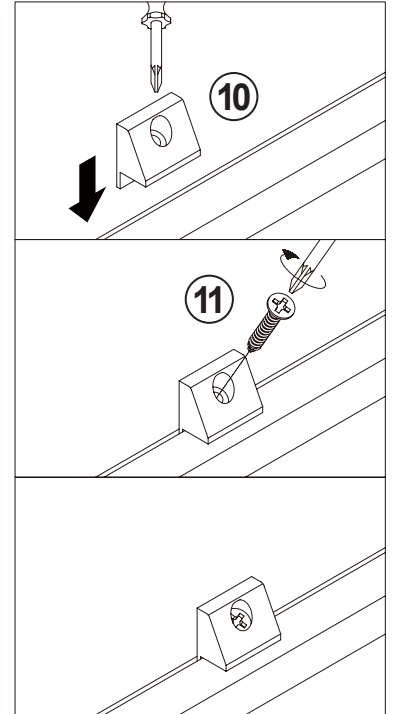
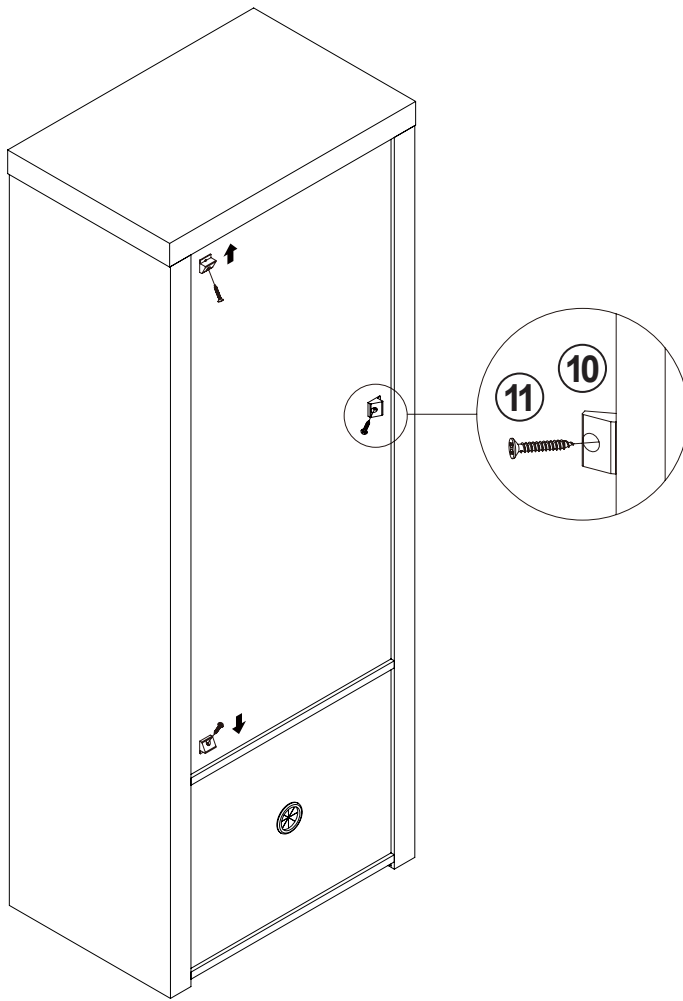

STEP 10

COMPLETE

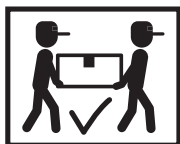
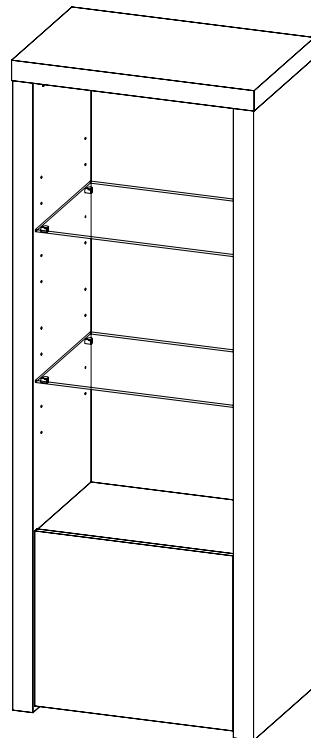

ITEM: 704254

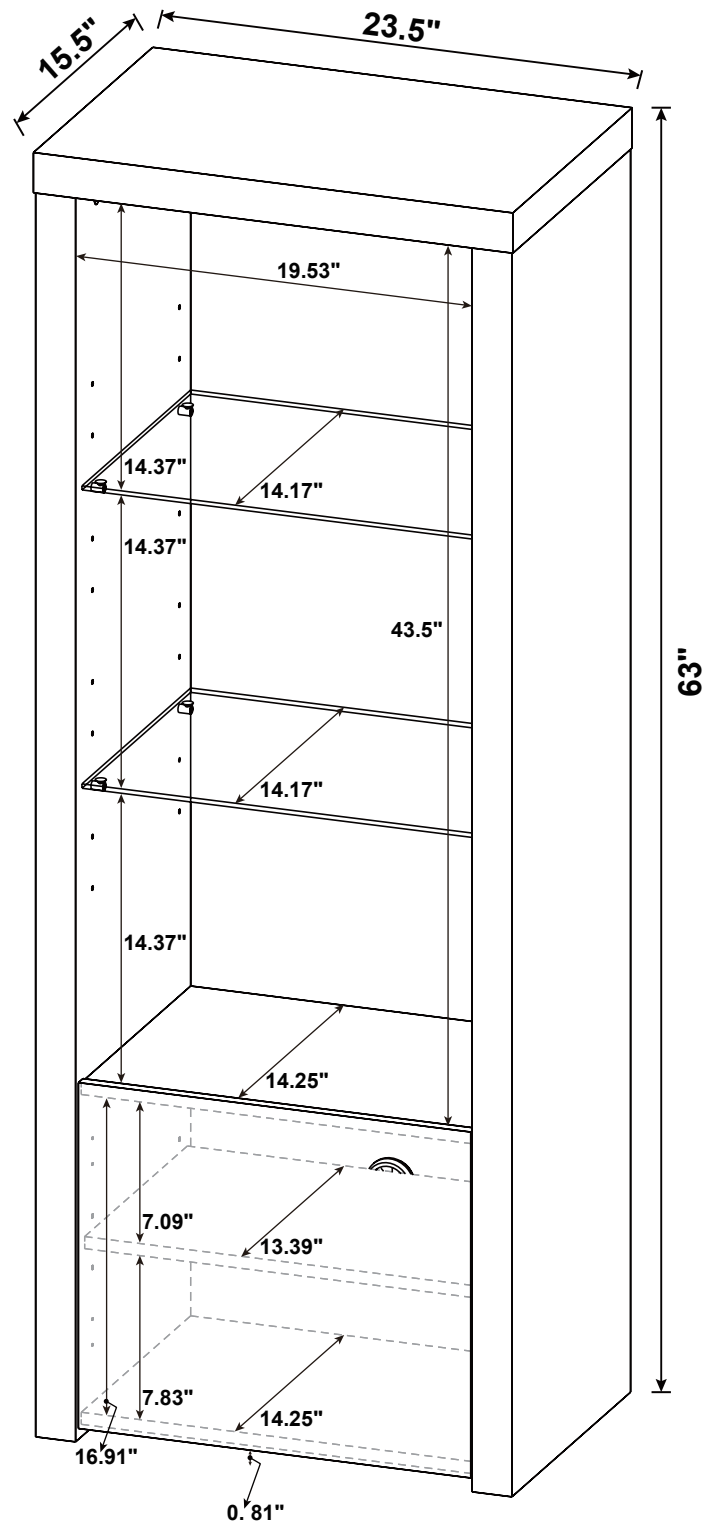

Note : Dimension tolerance $\pm 5\%$

ANTI-TIPPING INSTALLMENT INSTRUCTIONS FURNITURE TIPPING RESTRAINT

WARNING

Injury may result from tipping furniture.
This restraint may protect against tipping furniture.
Do not allow children to climb on furniture.
This restraint is not a substitute for proper adult supervision.
Failure to detach this restraint before moving the furniture may result in injury and damage.

This restraint must be screwed to a wood stud on the wall, using the long screw provided.

STEP 1

Secure the bracket to the back top of the unit, using the short screw provided, as shown in the drawing.

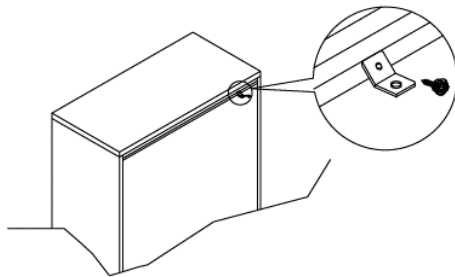

STEP 2

Locate the wood stud on the wall, and secure the other bracket, 2 inches below the back of the unit.

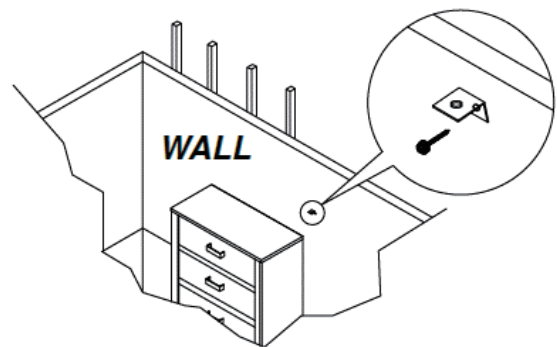

STEP 3

Place the furniture into position so both mounting brackets are vertically in line. Lace the end of the restraint strap through the larger hole in each mounting bracket. Bring both ends together and slide the flat end through the locking end, and drag it through, until the slack is removed. Ensure that the strap is securely laced and locked.

