

ASSEMBLY INSTRUCTIONS
COASTER FINE FURNITURE



Fine Furniture for every stage of life

950421
SHOE CABINET

ITEM:950421

ASSEMBLY INSTRUCTIONS

ASSEMBLY TIPS:

1. Remove hardware from box and sort by size.
2. Please check to see that all hardware and parts are present prior to start of assembly.
3. Please follow attached instructions in the same sequence as numbered to assure fast & easy assembly.



WARNING!

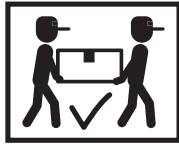

1. Don't attempt to repair or modify parts that are broken or defective. Please contact the store immediately.
2. This product is for home use only and not intended for commercial establishments.



ASSEMBLY TIME

60 MINUTES

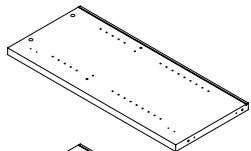
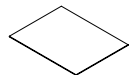
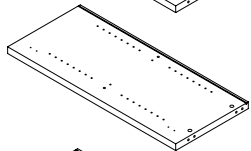
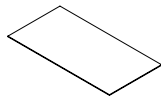
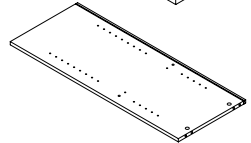
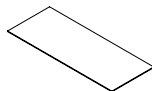
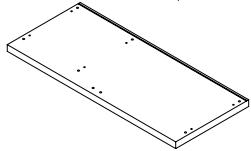
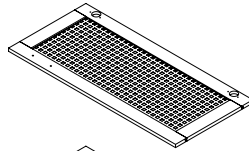
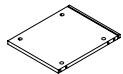
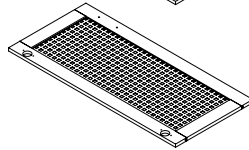
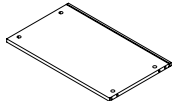
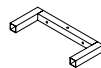
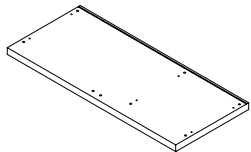
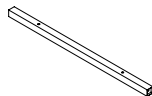
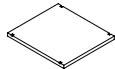
PARTS IDENTIFICATION

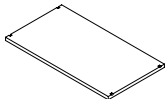







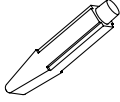
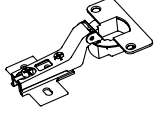
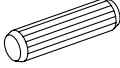

A	LEFT SIDE PANEL		1 PC	J	LEFT UPPER BACK PANEL		1 PC
B	RIGHT SIDE PANEL		1 PC	K	LEFT LOWER BACK PANEL		1 PC
C	MIDDLE DIVIDER PANEL		1 PC	L	RIGHT BACK PANEL		4 PCS
D	BOTTOM PANEL		1 PC	M	LEFT DOOR		1 PC
E	LEFT CROSS PANEL		1 PC	N	RIGHT DOOR		1 PC
F	RIGHT CROSS PANEL		1 PC	O	LEG FRAME		2 PCS
G	TOP PANEL		1 PC	P	CROSSBAR		1 PC
H	SMALL ADJUSTABLE SHELF		3 PCS	Q	BACK VERTICAL BAR		2 PCS
I	LARGE ADJUSTABLE SHELF		4 PCS				

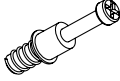
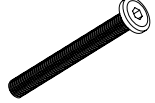
NOTE:

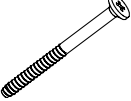
Phillips head screw driver is required in the assembly process; however, manufacturer does not provide this item.

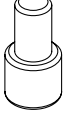
ITEM:950421

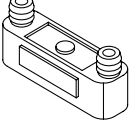
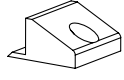
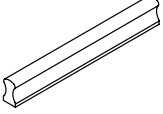
HARDWARE IDENTIFICATION

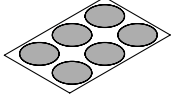
Z							
NO	DESCRIPTION	FIGURE	Q'TY	NO	DESCRIPTION	FIGURE	Q'TY
1	GLUE 15g		1 PC	10	HINGE Ø35mm SR		4 PCS
2	WOODEN DOWEL Ø8x30mm		20 PCS	11	HINGE SCREW Ø4x15mm SR		16 PCS
3	CAM BOLT Ø7x35.5mm SR		14 PCS	12	BOLT M6x58mm BLK		2 PCS
4	CAM LOCK Ø15x12mm SR		14 PCS	13	BOLT Ø7x50mm BLK		6 PCS
5	BOLT Ø9.5x55mm SR		6 PCS	14	FLOOR PROTECTOR 30x30mm		4 PCS
6	PIN FOR ADJUSTABLE SHELF Ø4.9x15mm SR		28 PCS	15	ALLEN WRENCH 4mm SR		1 PC
7	DOOR CATCH		2 PCS	16	BACK PANEL SUPPORT		6 PCS
8	HANDLE L= 120mm BLK		2 PCS	17	BACK PANEL SUPPORT SCREW Ø3x19mm SR		6 PCS
9	HANDLE BOLT BLK		4 PCS	18	STICKER Ø20mm		3 PCS

Z8,Z9,Z10 not included in blister packaging.

NOTE:

Phillips head screw driver is required in the assembly process; however, manufacturer does not provide this item.

ITEM: 950421

COASTER
FINE FURNITURE

STEP 1

2
x 16

3
x 4

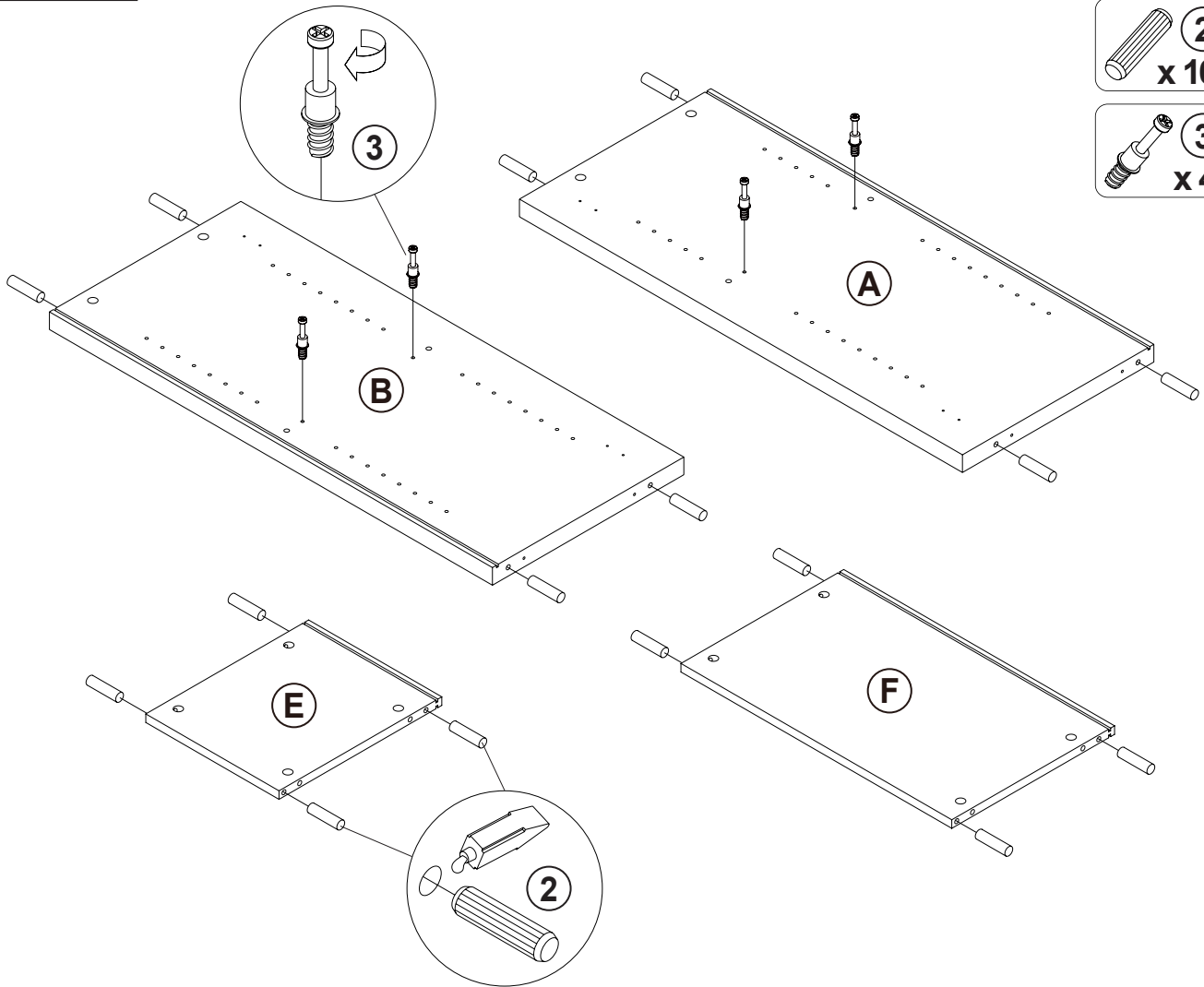

STEP 2

2
x 4

3
x 4

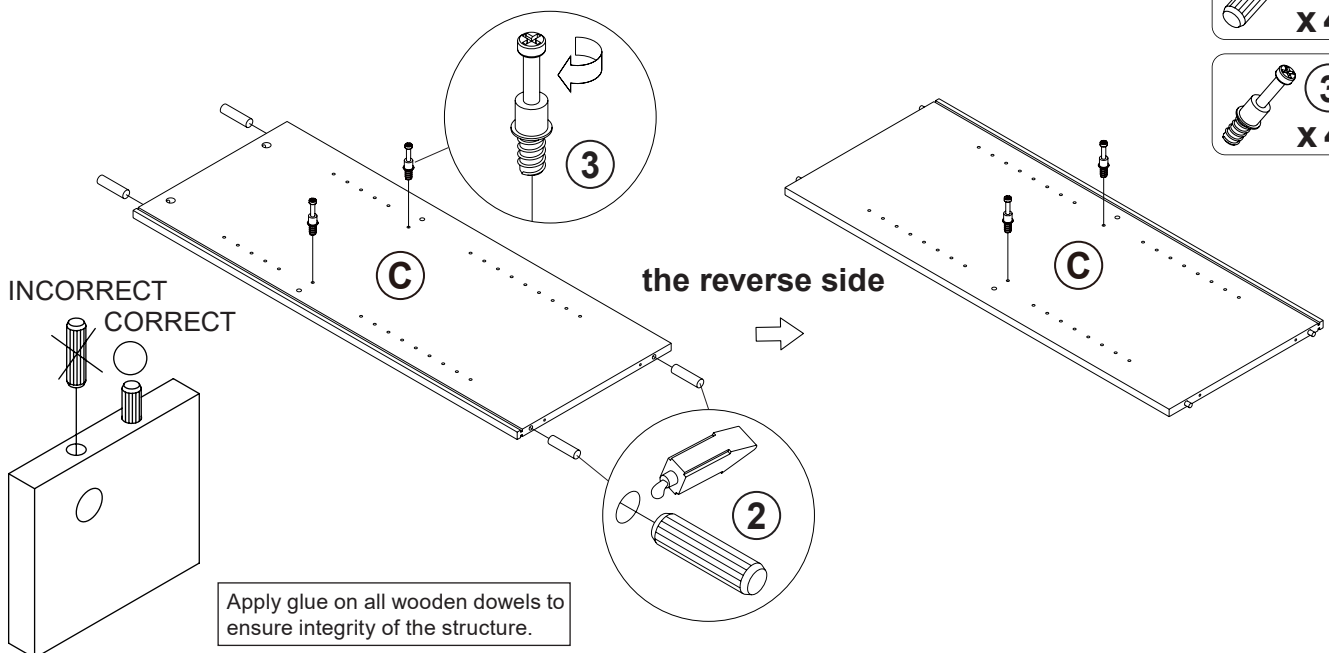

ITEM: **950421**

COASTER[®]

FINE FURNITURE

STEP 3

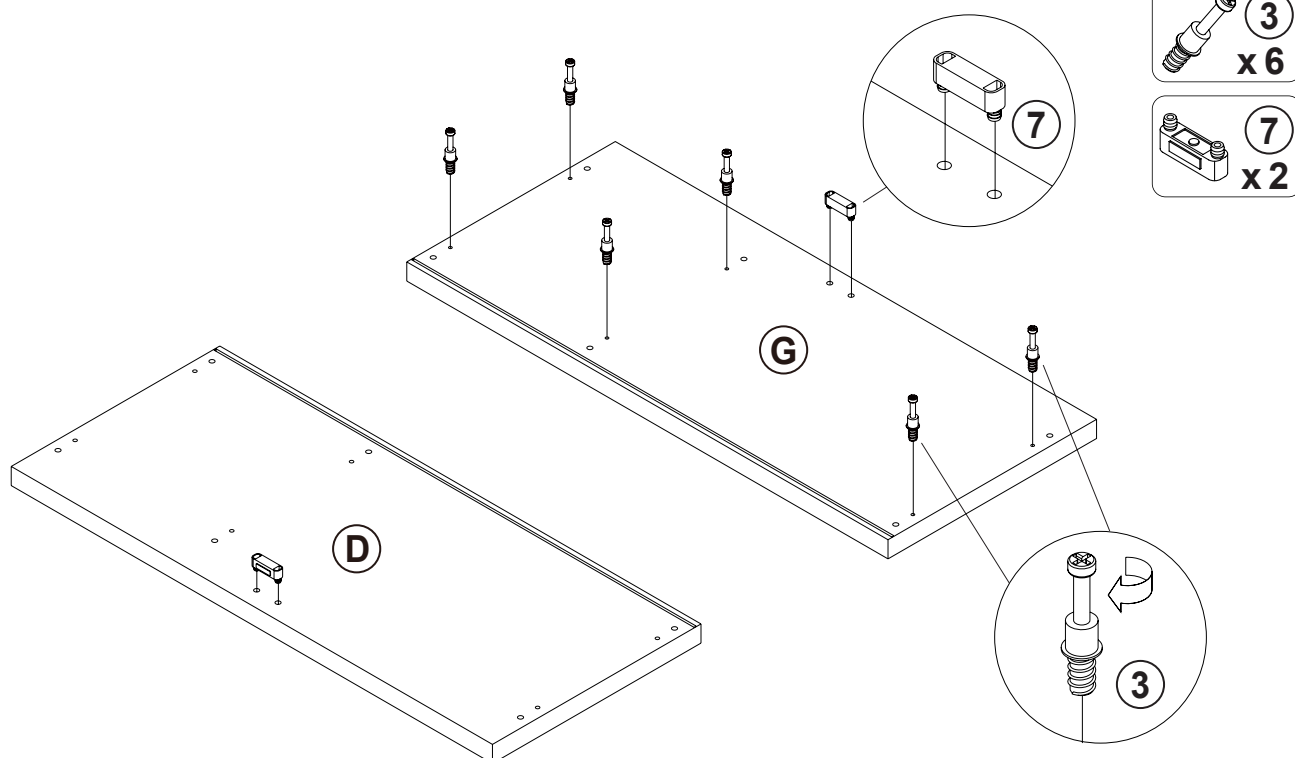

STEP 4

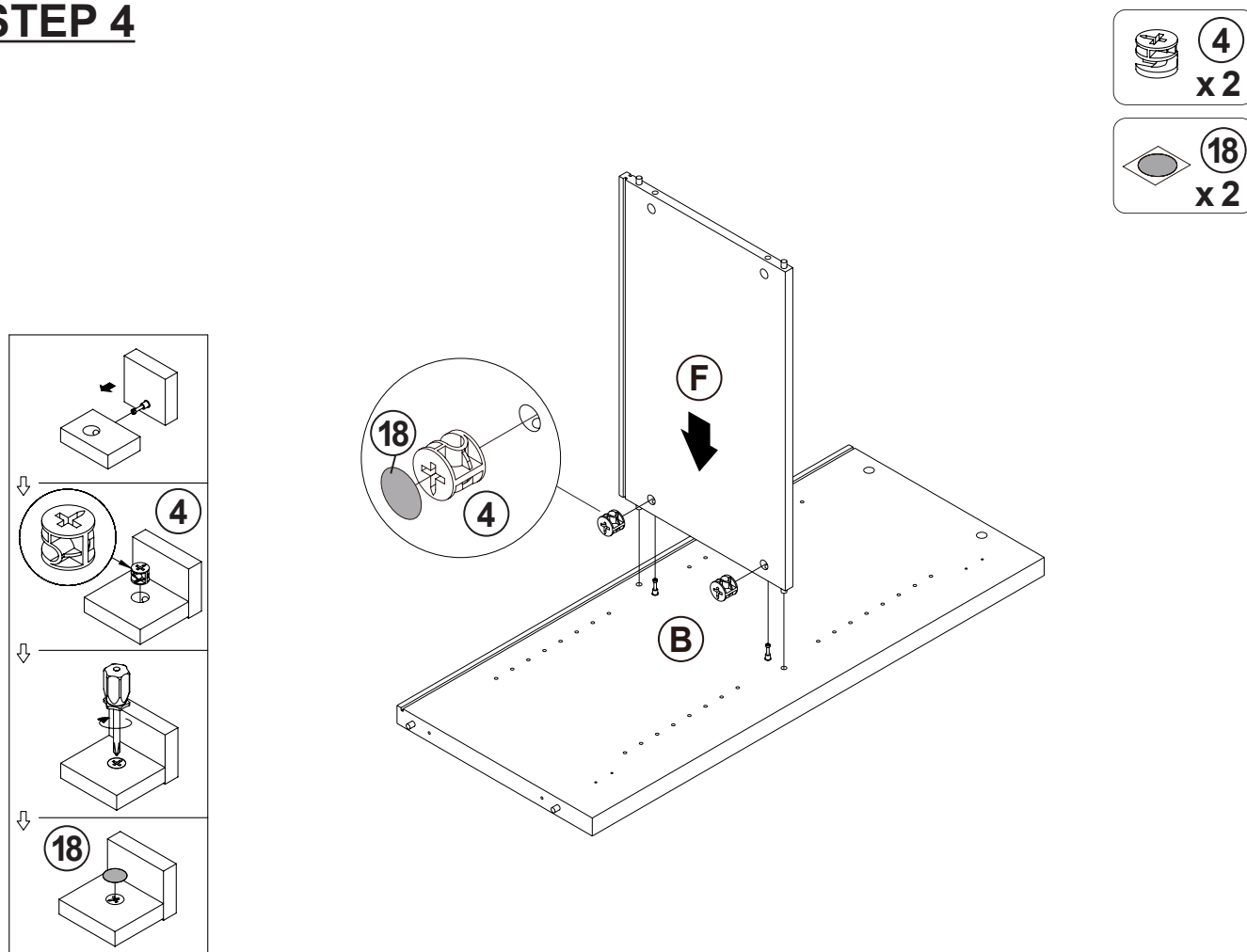

ITEM: **950421**

STEP 5

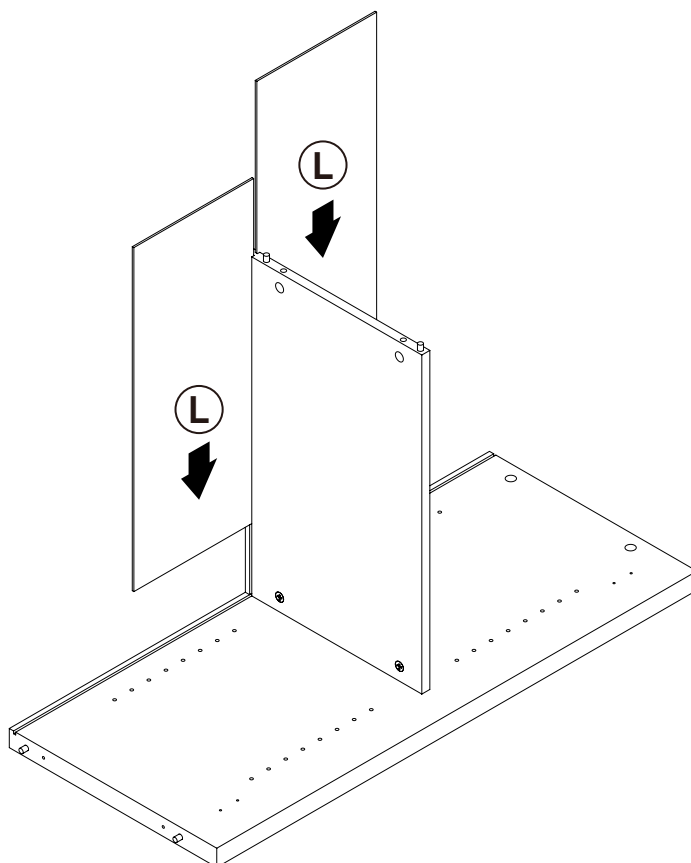

STEP 6

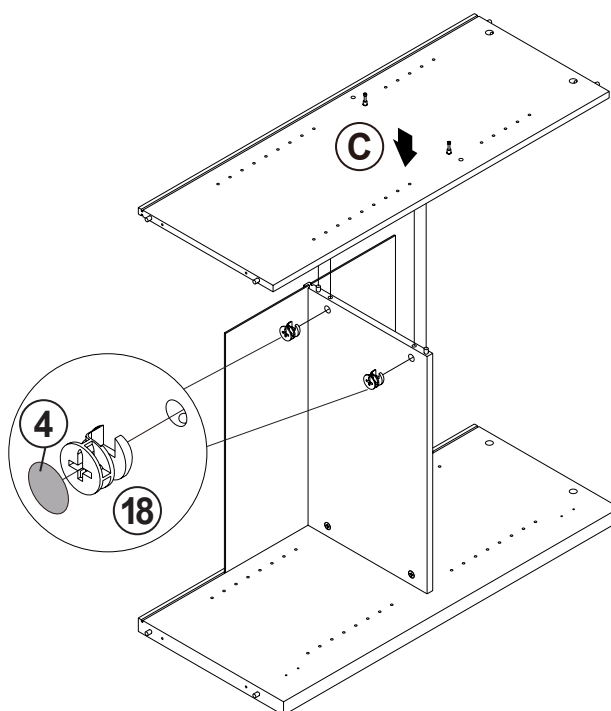
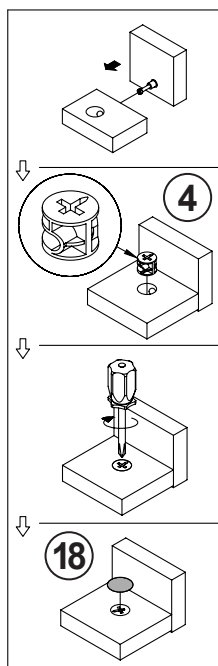
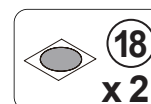

ITEM: 950421

STEP 7

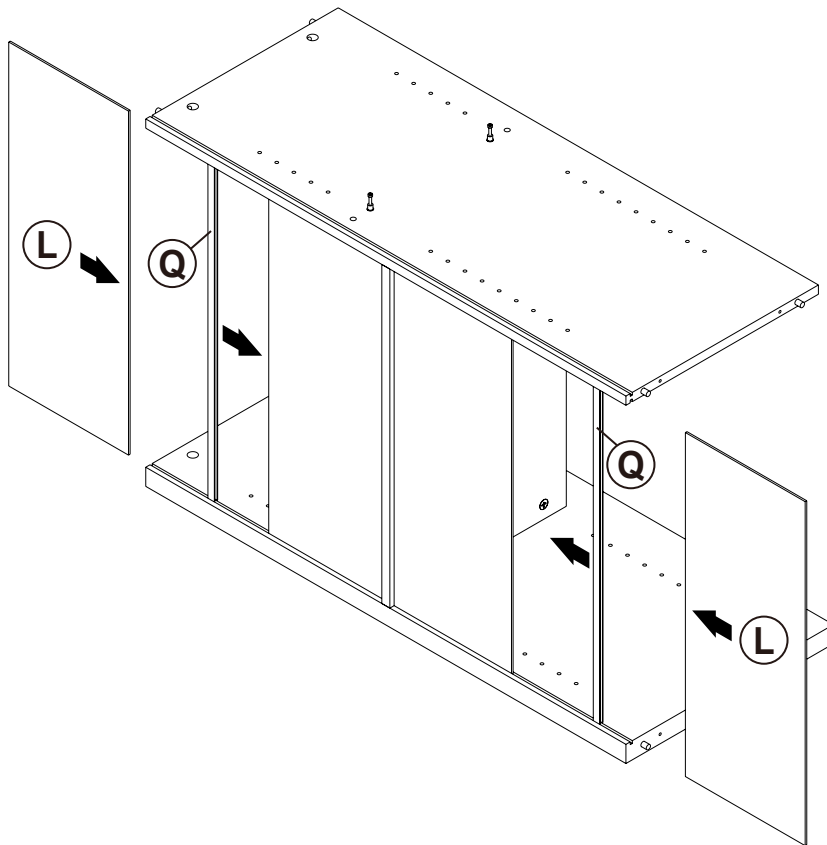

STEP 8

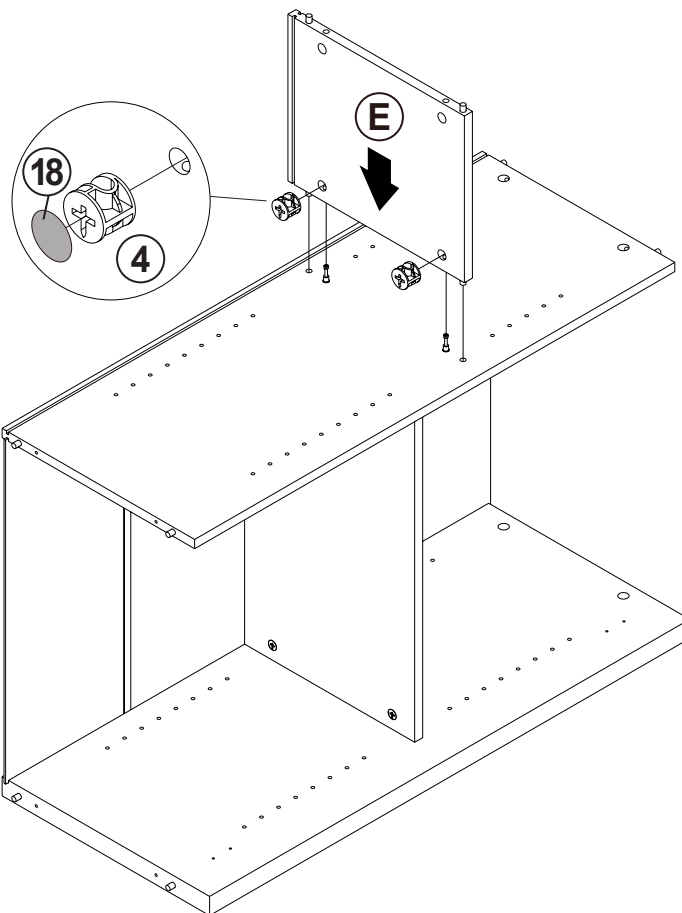
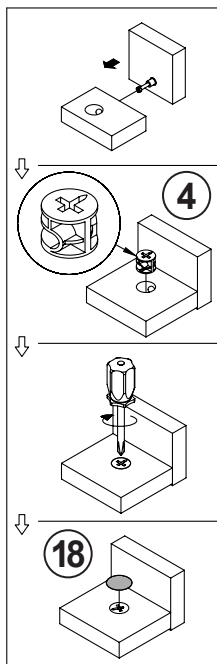
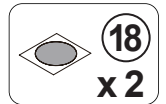

ITEM: **950421**

STEP 9

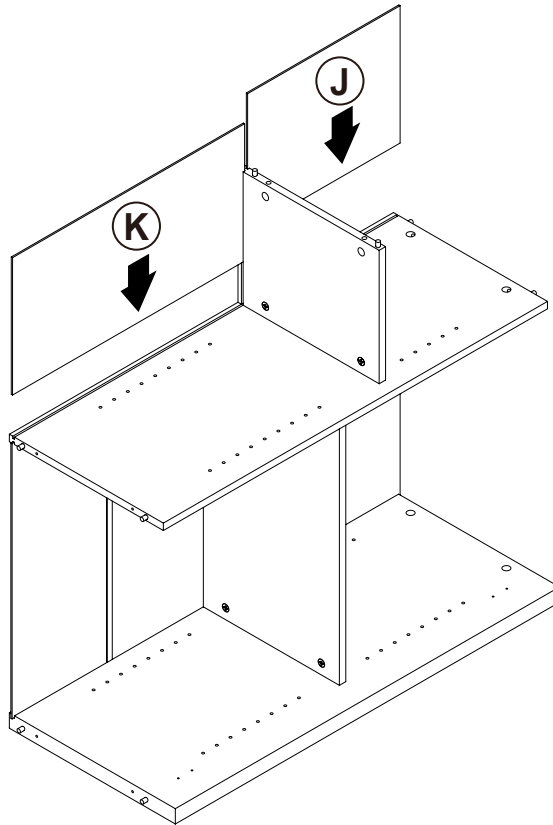

STEP 10

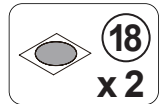
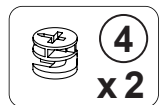
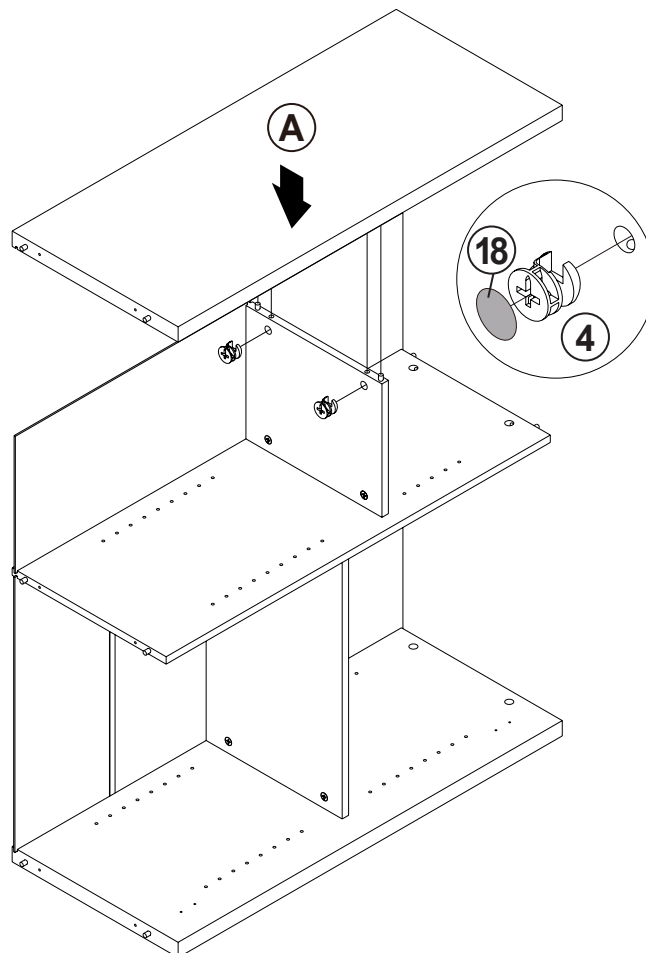
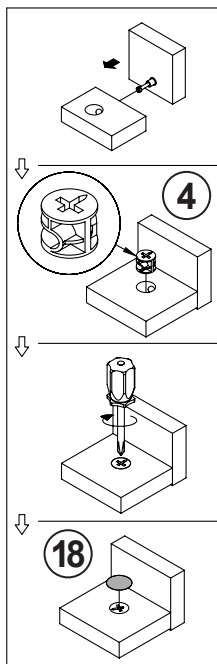

ITEM: 950421

COASTER
FINE FURNITURE

STEP 11

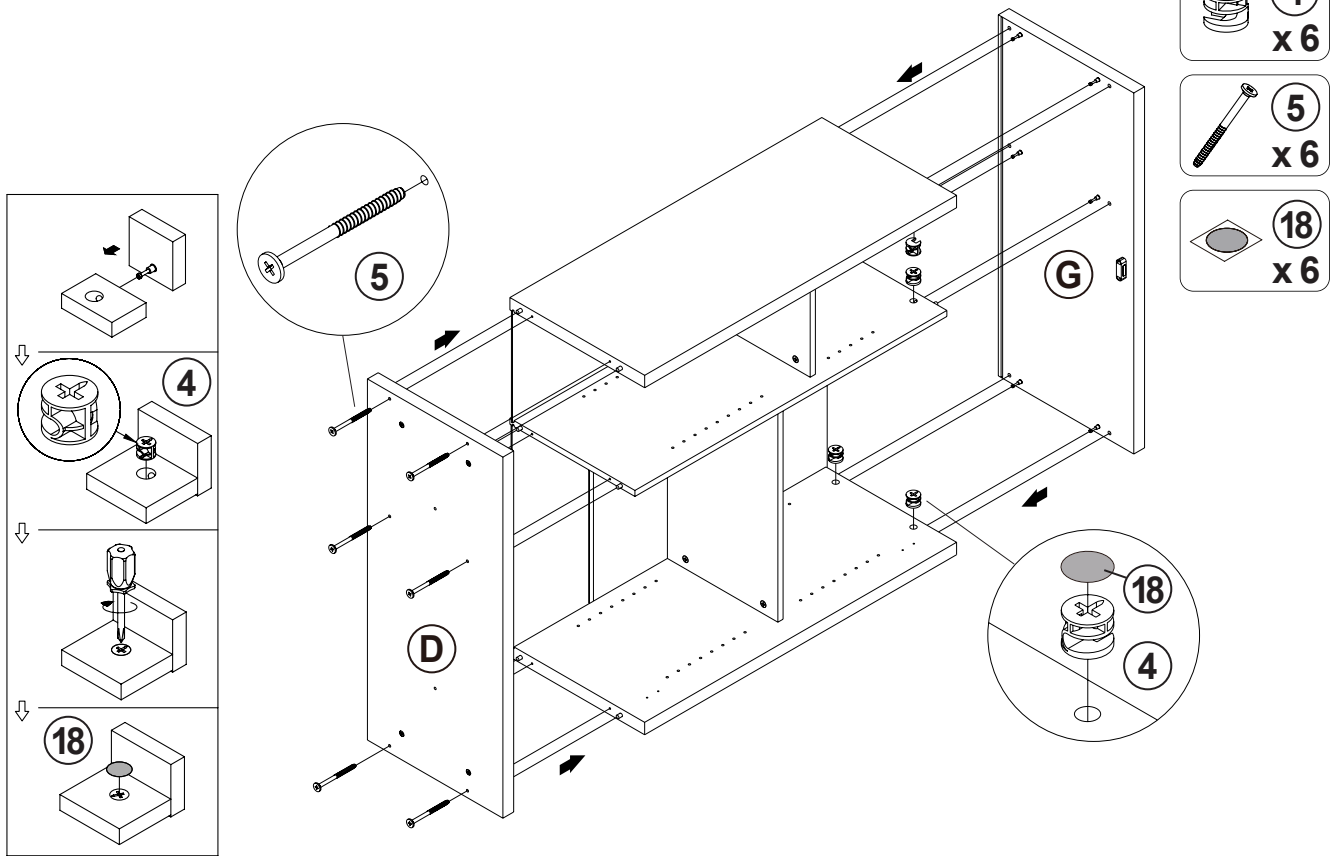

STEP 12

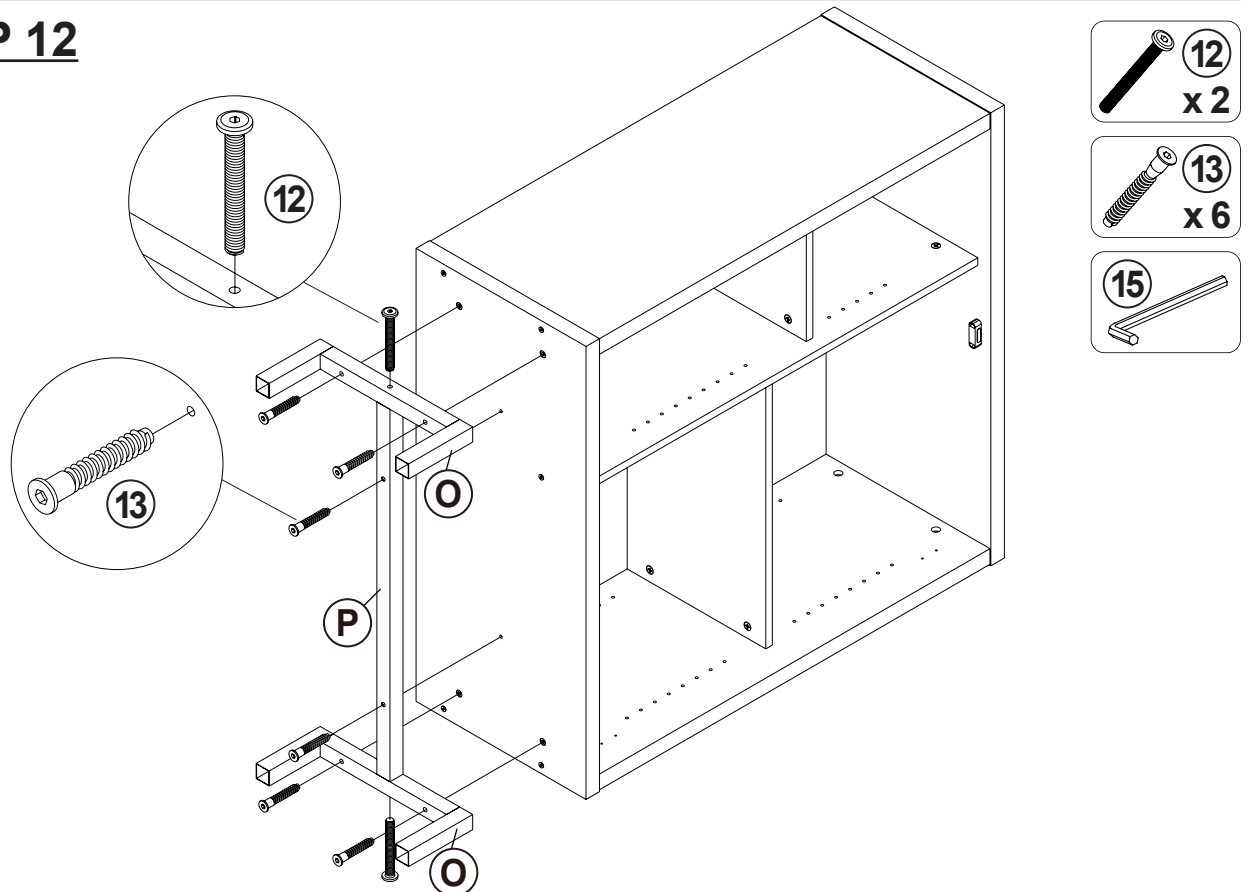

ITEM: **950421**

COASTER
FINE FURNITURE

STEP 13

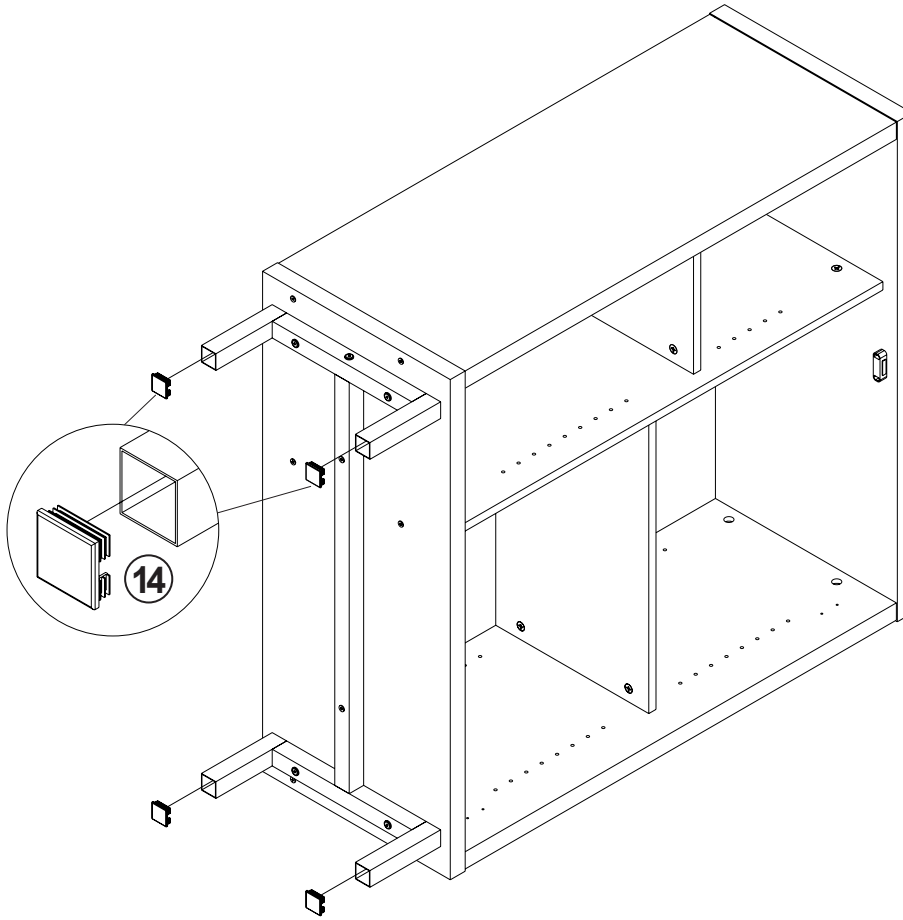
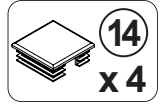

STEP 14

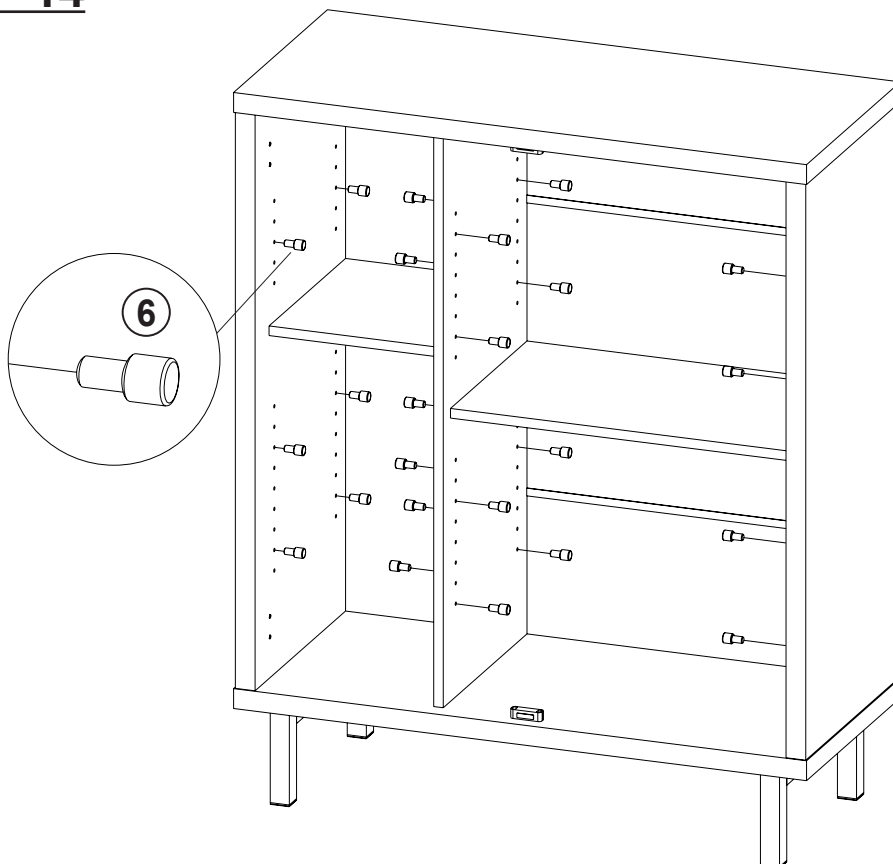
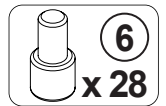

ITEM: 950421

STEP 15

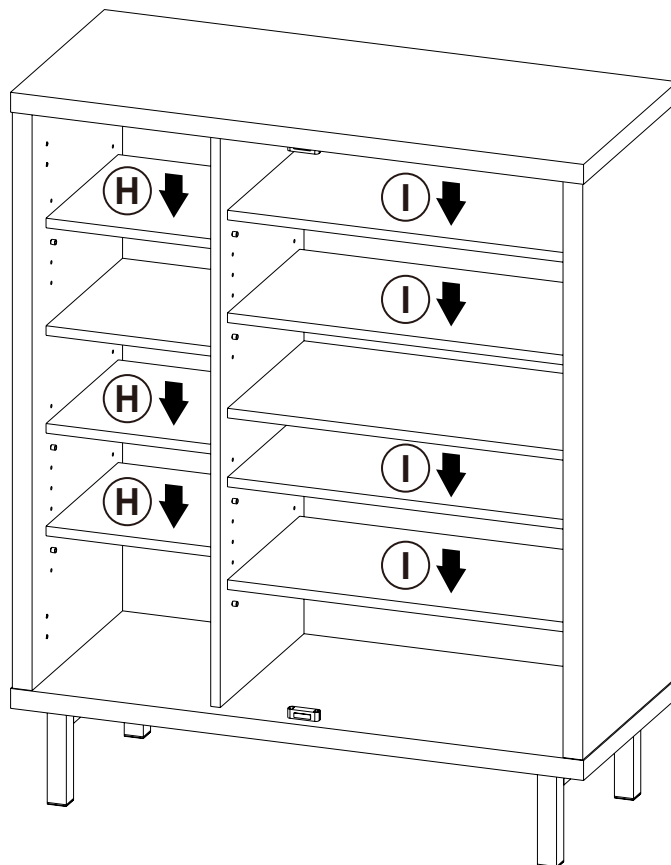

STEP 16

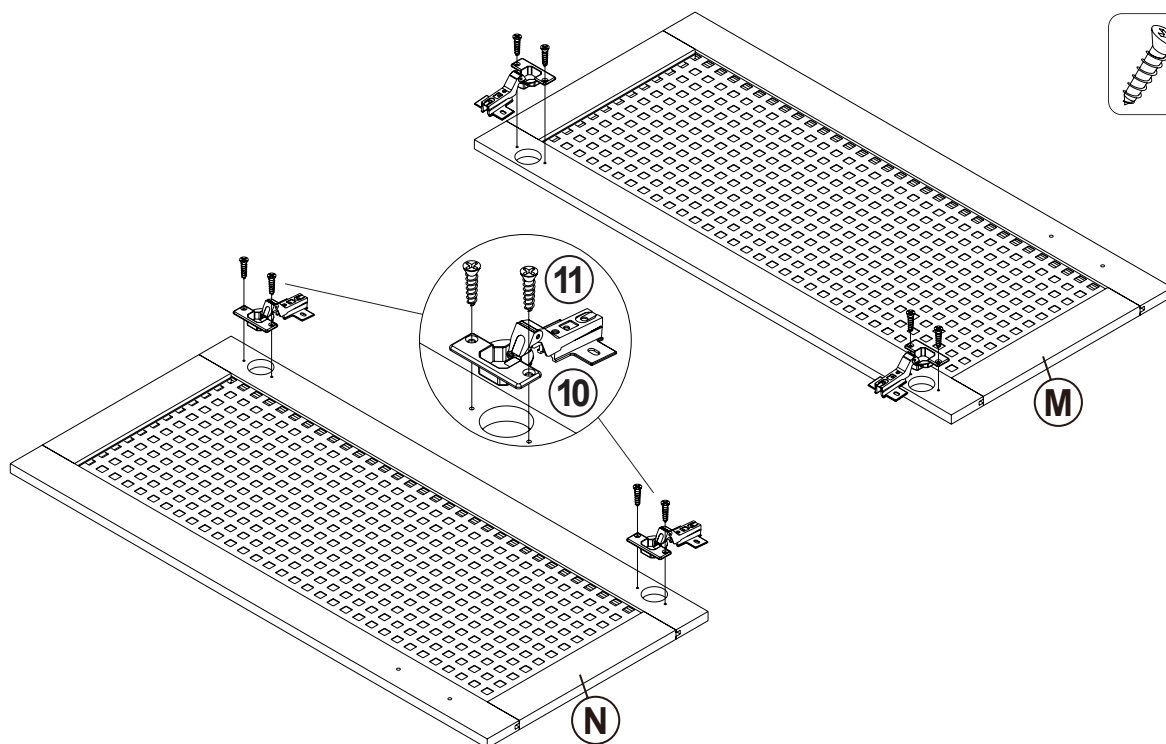
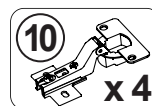

ITEM: **950421**

STEP 17

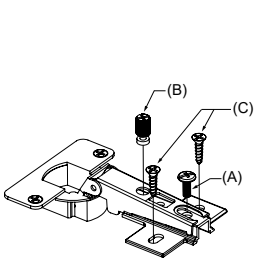

HORIZONTAL BY
SCREW A ADJUSTMENT

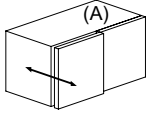

LATERAL BY
SCREW B ADJUSTMENT

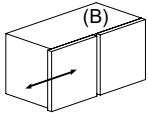

VERTICAL BY
SCREW C ADJUSTMENT

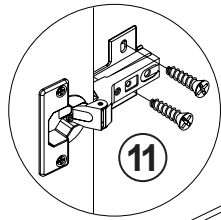
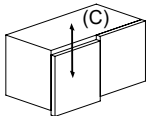

11

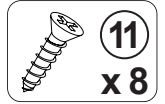
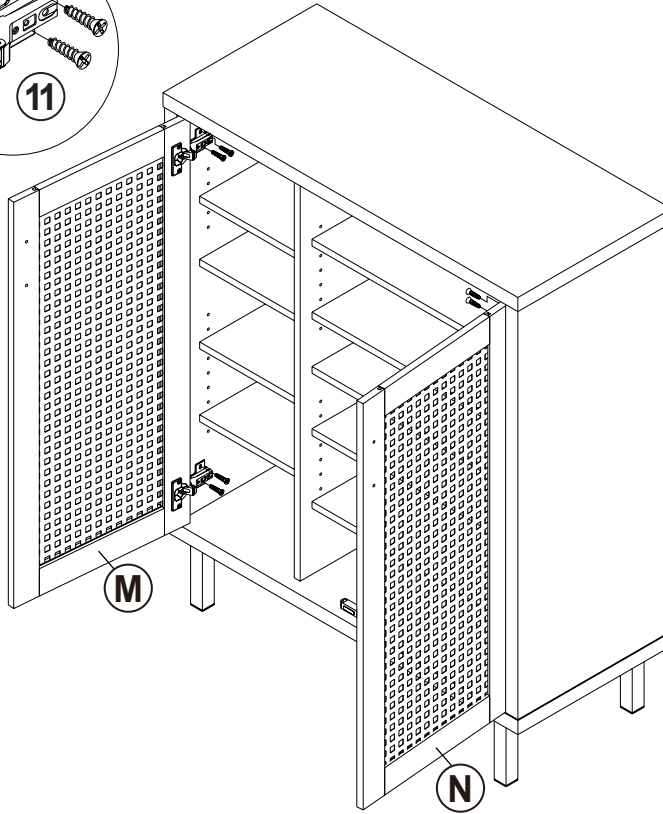

11

x 8

STEP 18

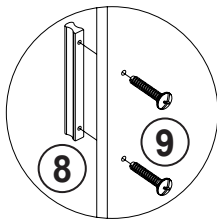

8

9

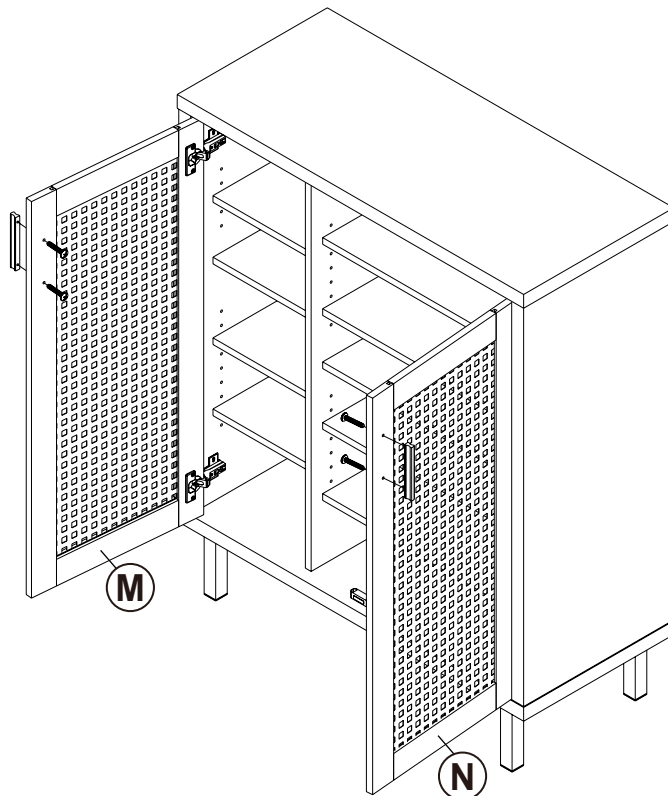

M

N

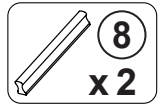

8

x 2

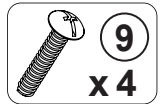

9

x 4

ITEM: **950421**

STEP 17

COASTER
FINE FURNITURE

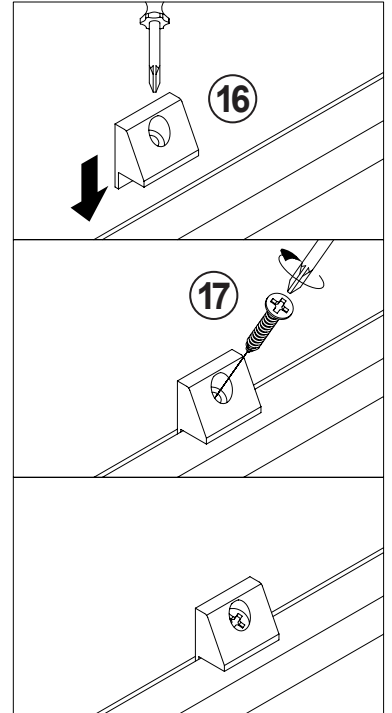
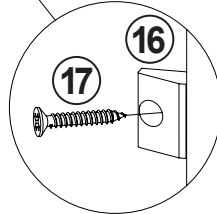
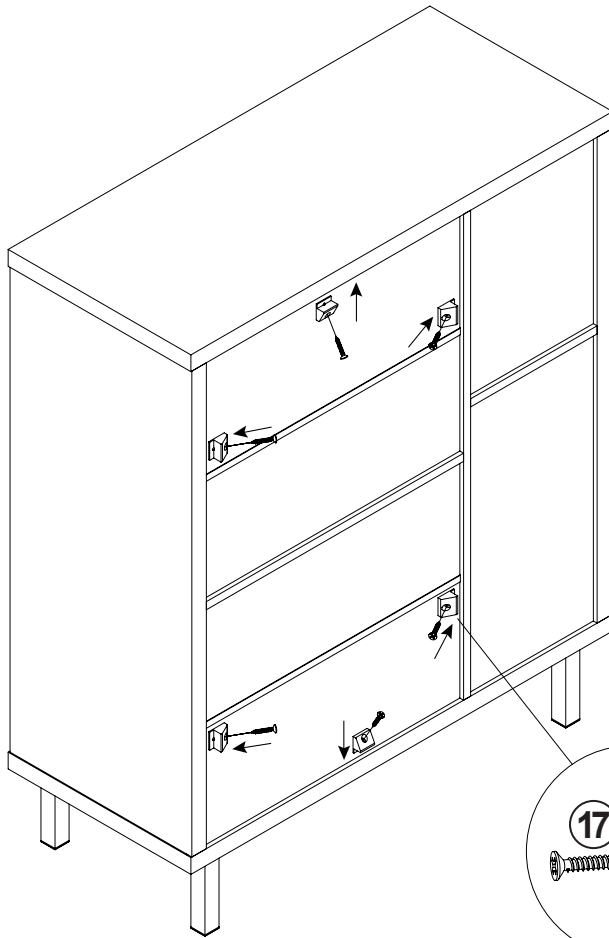
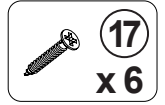
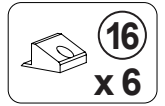

STEP 13

COMPLETE

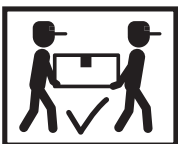
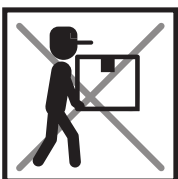
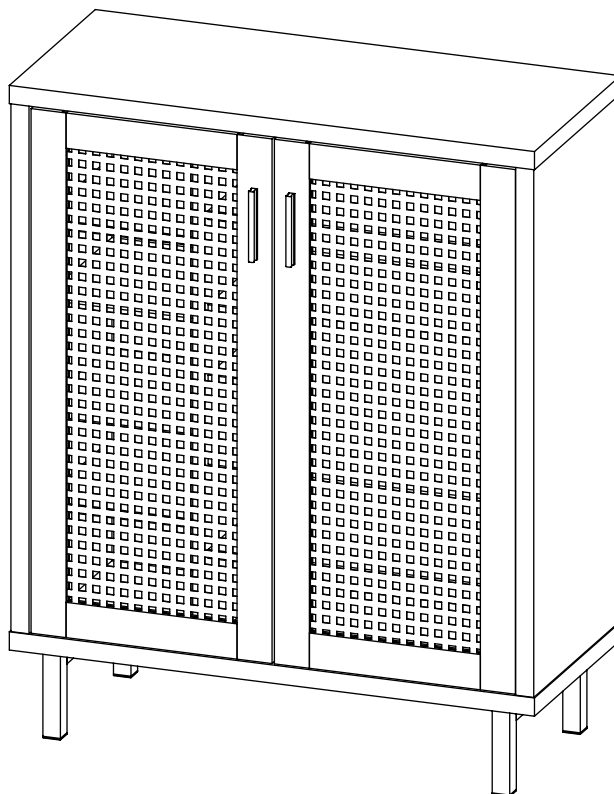

ITEM: 950421

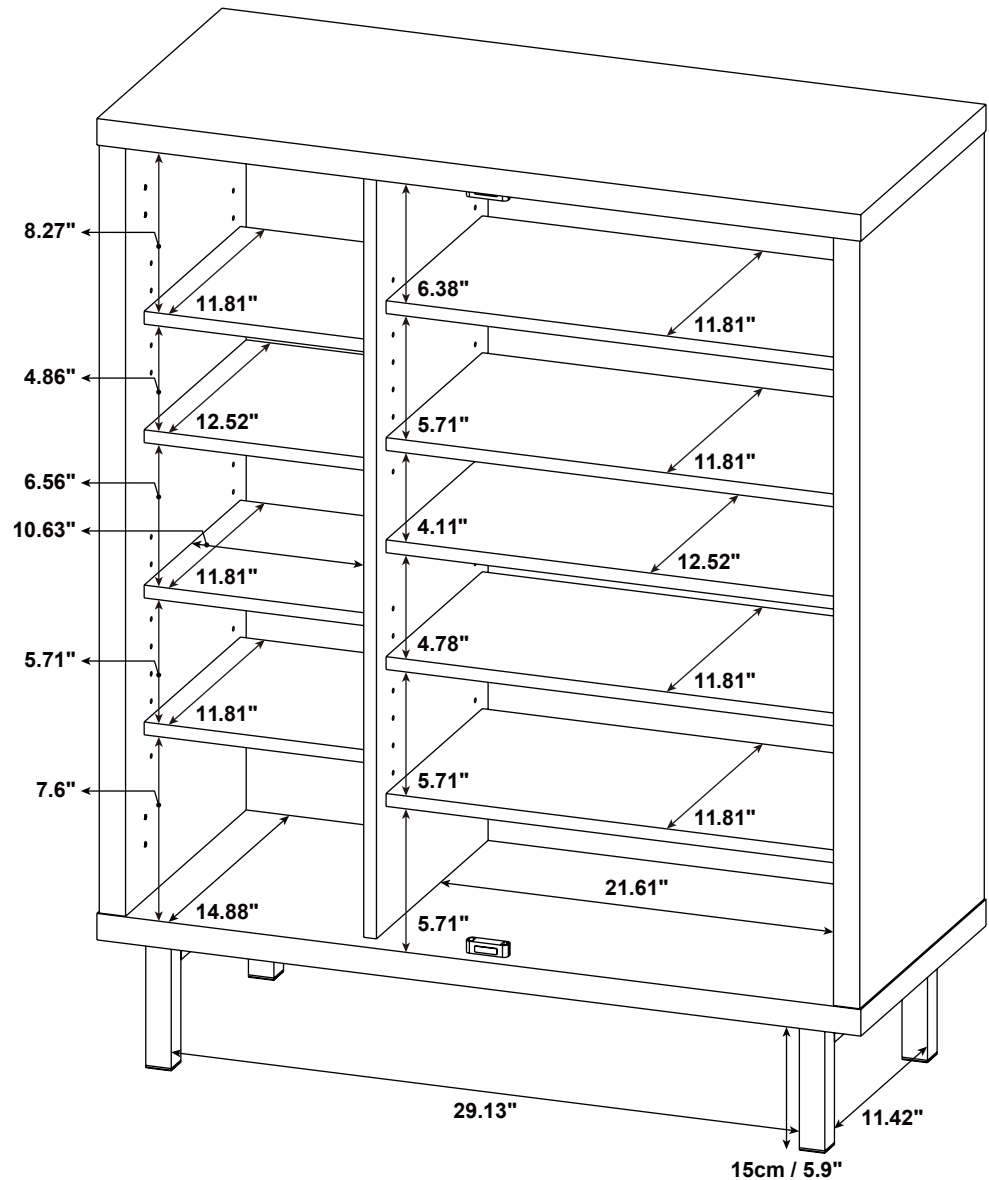
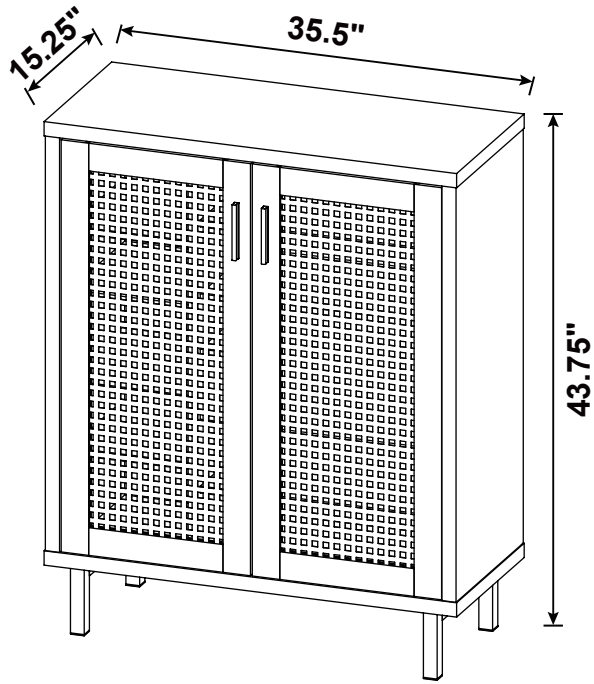

Note : Dimension tolerance $\pm 5\%$

ANTI-TIPPING INSTALLMENT INSTRUCTIONS FURNITURE TIPPING RESTRAINT

WARNING

Injury may result from tipping furniture.
This restraint may protect against tipping furniture.
Do not allow children to climb on furniture.
This restraint is not a substitute for proper adult supervision.
Failure to detach this restraint before moving the furniture may result in injury and damage.

This restraint must be screwed to a wood stud on the wall, using the long screw provided.

STEP 1

Secure the bracket to the back top of the unit, using the short screw provided, as shown in the drawing.

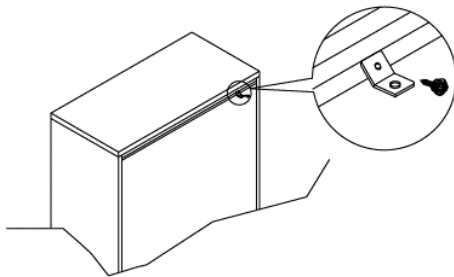

STEP 2

Locate the wood stud on the wall, and secure the other bracket, 2 inches below the back of the unit.

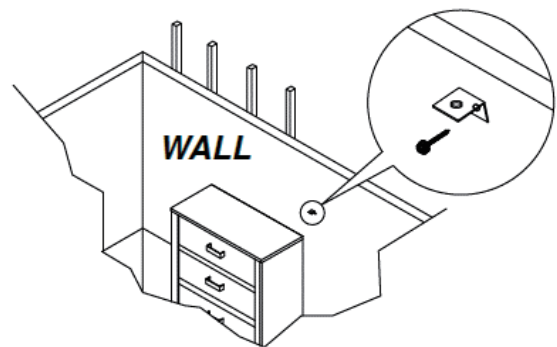

STEP 3

Place the furniture into position so both mounting brackets are vertically in line. Lace the end of the restraint strap through the larger hole in each mounting bracket. Bring both ends together and slide the flat end through the locking end, and drag it through, until the slack is removed. Ensure that the strap is securely laced and locked.

