

ASSEMBLY INSTRUCTIONS
COASTER FINE FURNITURE



Fine Furniture for every stage of life

108681
Dining Table

ITEM: **108681**



ASSEMBLY INSTRUCTIONS

ASSEMBLY TIPS:

1. Remove hardware from box and sort by size.
2. Please check to see that all hardware and parts are present prior to start of assembly.
3. Please follow attached instructions in the same sequence as numbered to assure fast & easy assembly.



WARNING!



1. Don't attempt to repair or modify parts that are broken or defective. Please contact the store immediately.
2. This product is for home use only and not intended for commercial establishments.







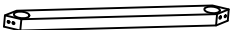

ASSEMBLY TIME

20 MINUTES

PARTS IDENTIFICATION

A	TOP		1PC
B	LEG WITH LABEL "B"		2PCS
C	LEG WITH LABEL "C"		2PCS
D	TRESTLE BAR		1PC

HARDWARE IDENTIFICATION

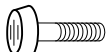
1	BOLT (M8 X 70MM - RBW)		8PCS
2	LOCK WASHER (M8 X 13MM - RBW)		12PCS
3	FLAT WASHER (M8 X 19MM - RBW)		12PCS
4	WOOD DOWEL (M10 X 30MM)		4PCS
5	HEX NUT (M8 - RBW)		4PCS
6	WRENCH (M8 - RBW)		1PC
7	ALLEN WRENCH (M5 X 65MM - BLK)		1PC
8	LEVELER		4PCS

ITEM: **108681**

ASSEMBLY INSTRUCTIONS



STEP 1

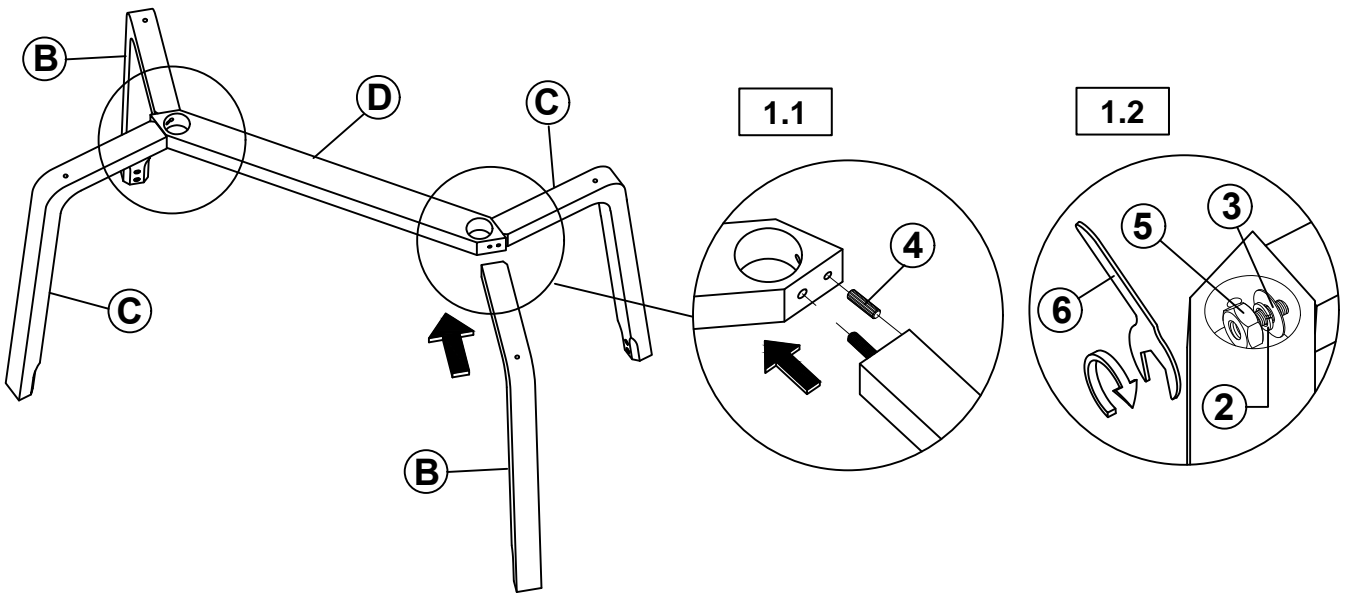

STEP 2

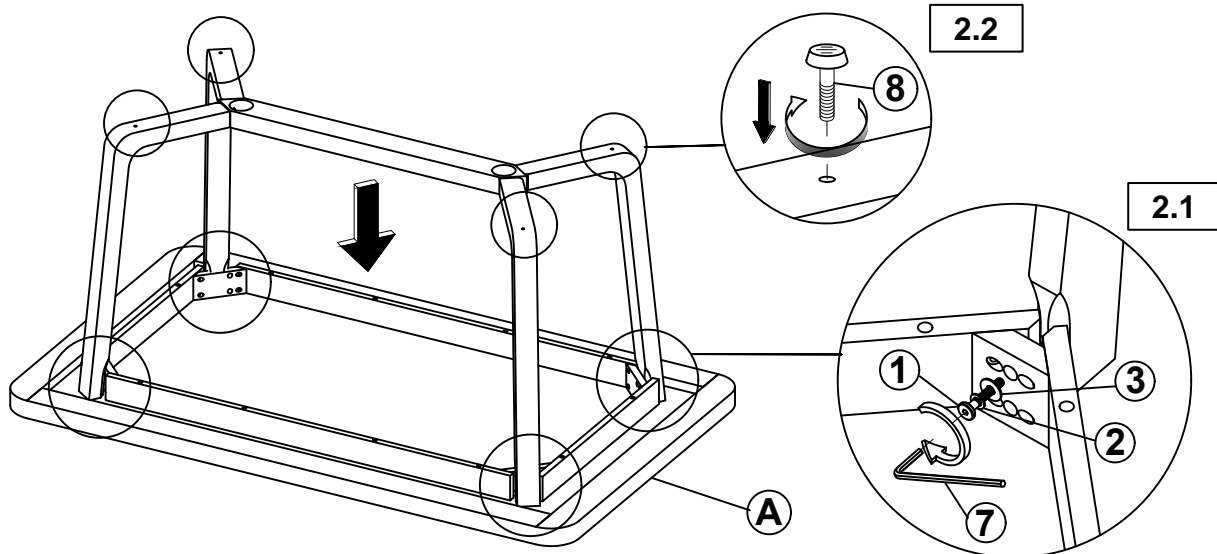

STEP 3

COMPLETE

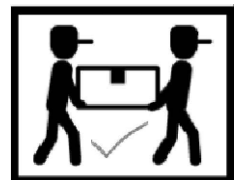
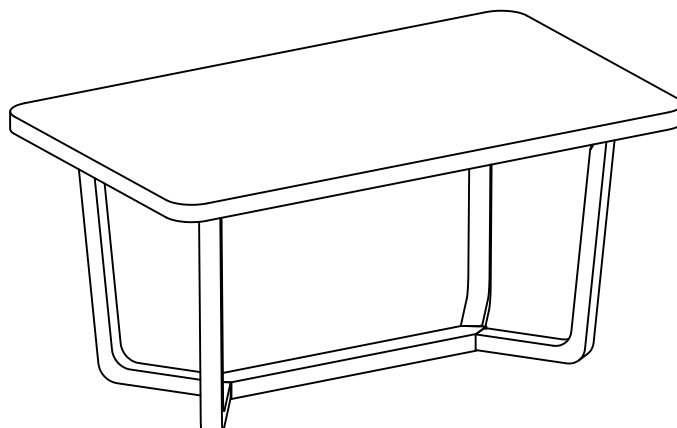

ITEM: 108681

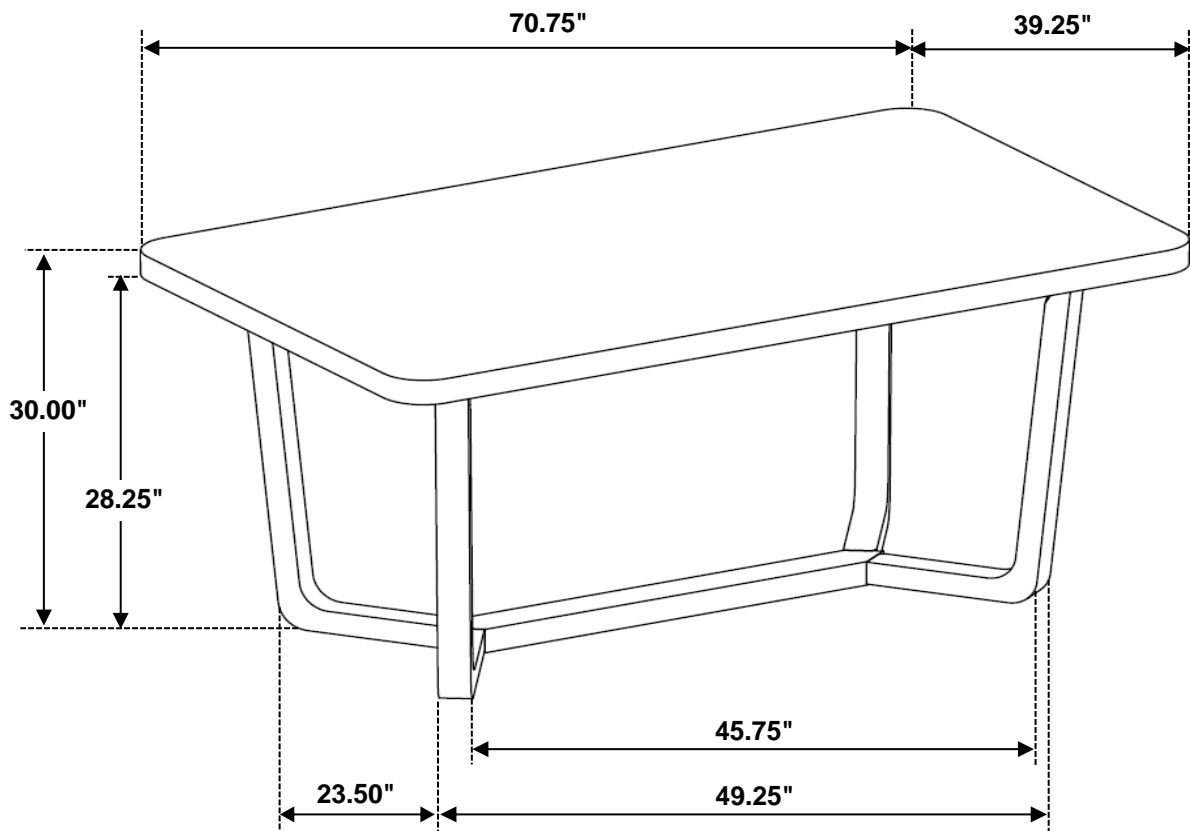

Note: Dimension tolerance $\pm 5\%$