

**ASSEMBLY INSTRUCTIONS**  
**COASTER FINE FURNITURE**



*Fine Furniture for every stage of life*

**108682**  
**Side Chair**

ITEM: **108682**



## ASSEMBLY INSTRUCTIONS

### ASSEMBLY TIPS:

1. Remove hardware from box and sort by size.
2. Please check to see that all hardware and parts are present prior to start of assembly.
3. Please follow attached instructions in the same sequence as numbered to assure fast & easy assembly.



### WARNING!





1. Don't attempt to repair or modify parts that are broken or defective. Please contact the store immediately.
2. This product is for home use only and not intended for commercial establishments.





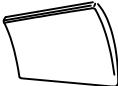

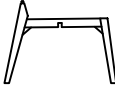
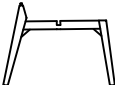

ASSEMBLY TIME

15 MINUTES

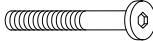
## PARTS IDENTIFICATION

A	BACKREST		1PC
B	SEAT CUSHION		1PC
C	BACKREST SUPPORT		1PC
D	CORNER BLOCK		1PC
E	UPPER LEG FRAME		1PC
F	LOWER LEG FRAME		1PC

## HARDWARE IDENTIFICATION

1	LONG BOLT (M6 X 60MM - RBW)		4PCS
2	SHORT BOLT (M6 X 45MM - RBW)		3PCS
3	LOCK WASHER (M6 X 13MM - RBW)		5PCS
4	LONG FLAT HEAD SCREW (M4 X 32MM - RBW)		2PCS
5	FLAT WASHER (M6 X 13MM - RBW)		2PCS
6	SHORT FLAT HEAD SCREW (M4 X 28MM - RBW)		4PCS
7	ALLEN WRENCH (M4 X 110MM - BLK)		1PC
8	WOOD BUTTON		1PC

### NOTE:

Quantities shown are for one chair.

Phillips head screw driver is required in the assembly process; however, manufacturer does not provide this item.

ITEM: **108682**

**ASSEMBLY INSTRUCTIONS**

**STEP 1**

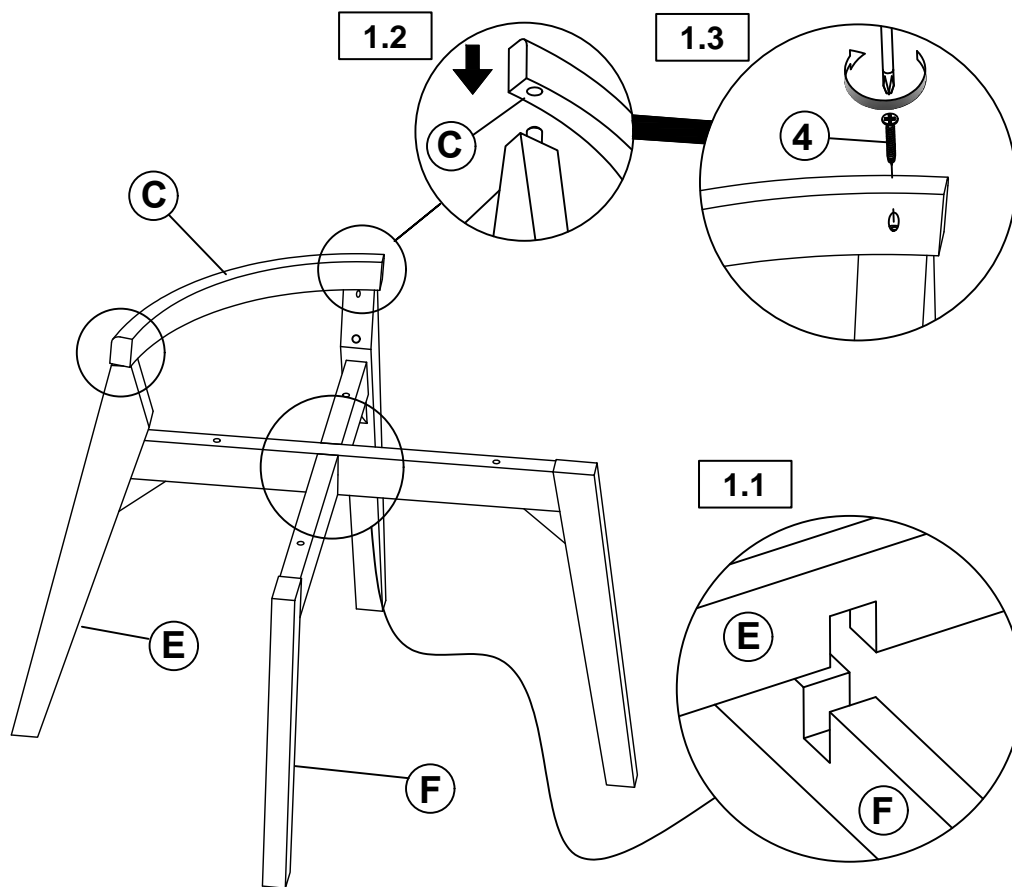

**STEP 2**

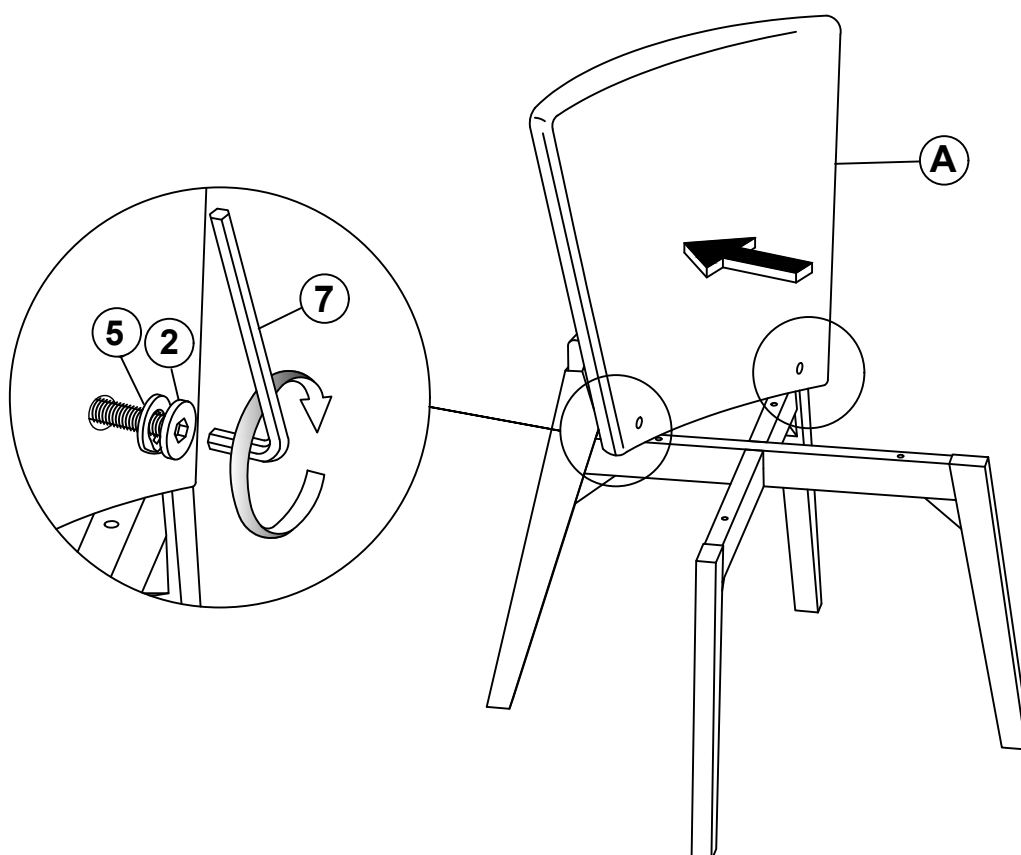

ITEM: **108682**  
**ASSEMBLY INSTRUCTIONS**  
**STEP 3**

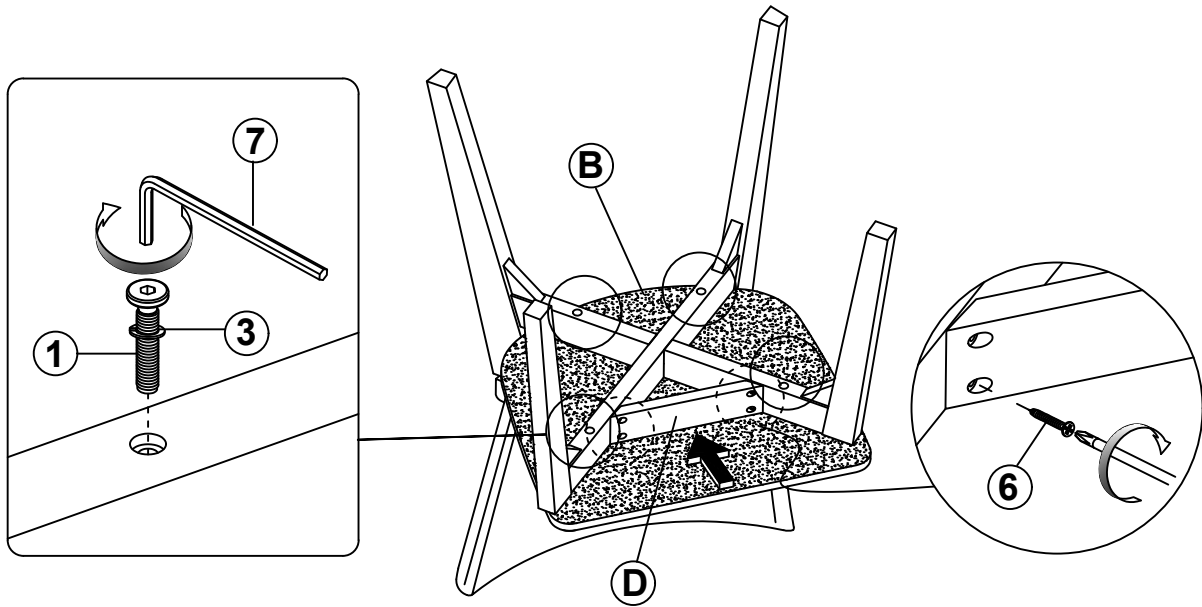

**STEP 4**

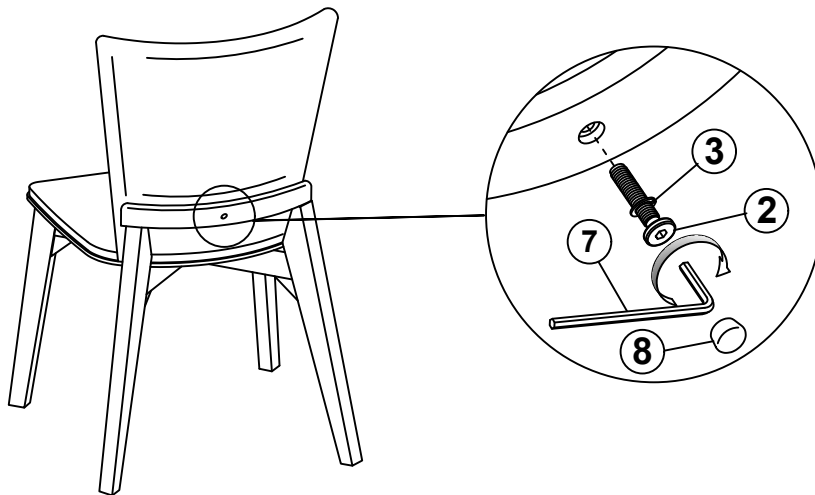

**STEP 5**  
**COMPLETE**

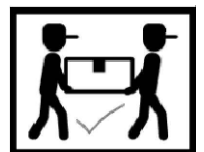
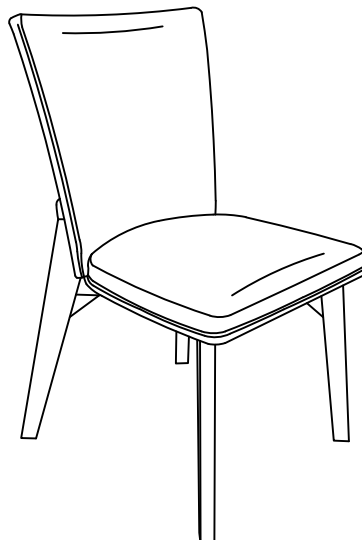

ITEM: 108682

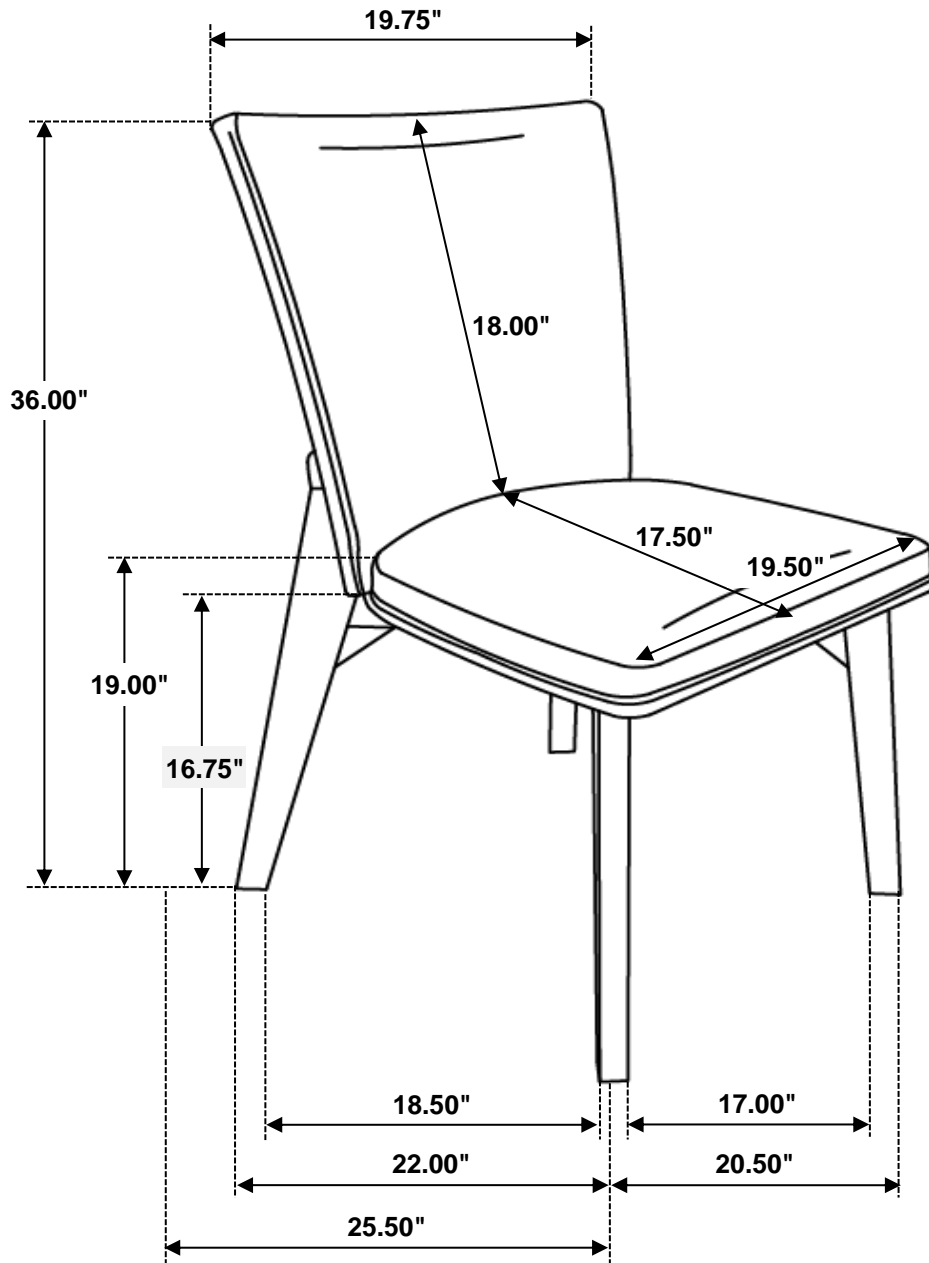

Note: Dimension tolerance  $\pm 5\%$