

ASSEMBLY INSTRUCTIONS
COASTER FINE FURNITURE



Fine Furniture for every stage of life

223441Q (B1&B2)
Queen Bed

ITEM: 223441Q (B1&B2)



ASSEMBLY INSTRUCTIONS

ASSEMBLY TIPS:

1. Remove hardware from box and sort by size.
2. Please check to see that all hardware and parts are present prior to start of assembly.
3. Please follow attached instructions in the same sequence as numbered to assure fast & easy assembly.



WARNING!

1. Don't attempt to repair or modify parts that are broken or defective. Please contact the store immediately.
2. This product is for home use only and not intended for commercial establishments.









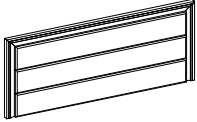

ASSEMBLY TIME

30 MINUTES

PARTS IDENTIFICATION

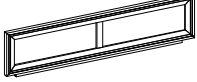
B1 (BOX 1)

A	HEADBOARD PANEL		1PC	E	LEFT FOOTBOARD LEG (WITH "L" LABEL)		1PC
B	LEFT HEADBOARD LEG (WITH "L" LABEL)		1PC	F	RIGHT FOOTBOARD LEG (WITH "R" LABEL)		1PC
C	RIGHT HEADBOARD LEG (WITH "R" LABEL)		1PC	G	BED SLAT		4PCS
D	FOOTBOARD PANEL		1PC	H	BED SLAT SUPPORT WITH LEVELER		4PCS

B2 (BOX 2)

I	BED RAIL		2PCS
---	----------	---	------

ITEM: 223441Q (B1&B2)



ASSEMBLY INSTRUCTIONS

ASSEMBLY TIPS:

1. Remove hardware from box and sort by size.
2. Please check to see that all hardware and parts are present prior to start of assembly.
3. Please follow attached instructions in the same sequence as numbered to assure fast & easy assembly.











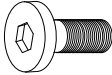

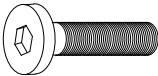
WARNING!

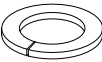
1. Don't attempt to repair or modify parts that are broken or defective. Please contact the store immediately.
2. This product is for home use only and not intended for commercial establishments.

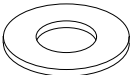
HARDWARE IDENTIFICATION

Z-B1 (BOX 1) - HARDWARE IS LOCATED IN 223441Q (B1)

1	SHORT BOLT (M8 x 16MM - RBW)		8PCS	6	SMALL LOCK WASHER (1/4" x 13Ø - RBW)		4PCS
2	MEDIUM BOLT (M8 x 35MM - RBW)		6PCS	7	SMALL FLAT WASHER (1/4" x 19Ø - RBW)		4PCS
3	BIG LOCK WASHER (5/16" x 14Ø - RBW)		6PCS	8	FLAT HEAD SCREW (M4 x 32MM - RBW)		8PCS
4	BIG FLAT WASHER (5/16" x 22Ø - RBW)		6PCS	9	BIG ALLEN WRENCH (M5 x 68MM - BLK)		1PC
5	LONG BOLT (M6 x 40MM - RBW)		4PCS	10	SMALL ALLEN WRENCH (M4 x 60MM - BLK)		1PC

NOTE:

Phillips head screw driver is required in the assembly process; however, manufacturer does not provided this item.

ITEM: 223441Q (B1&B2)

ASSEMBLY INSTRUCTIONS

STEP 1

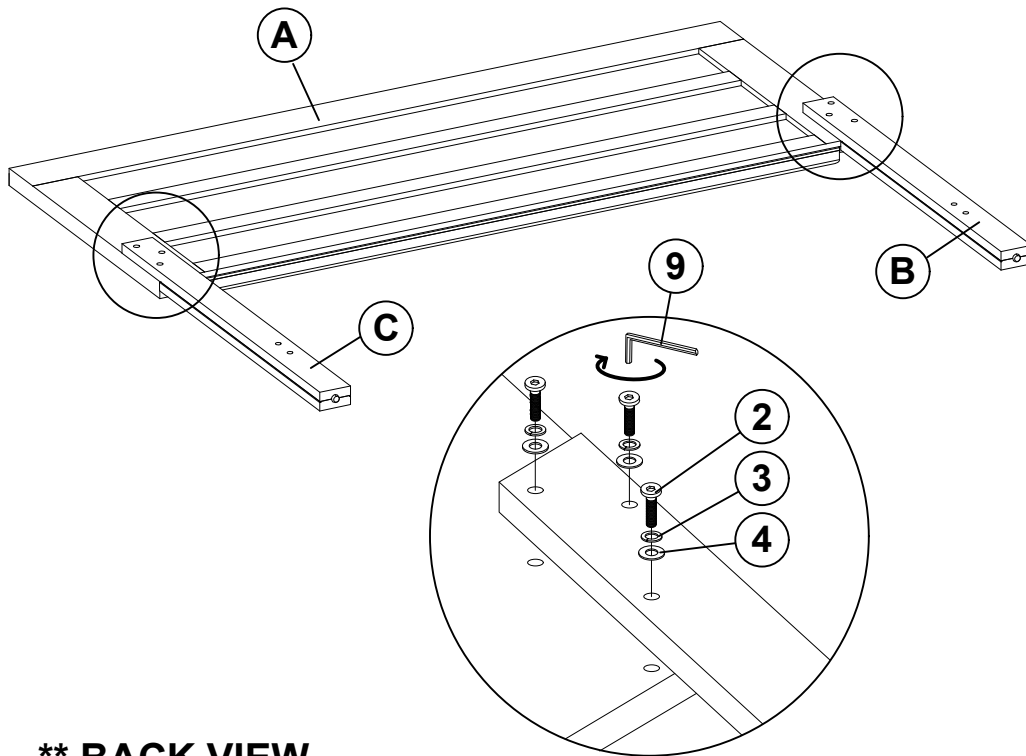

**** BACK VIEW**

STEP 2

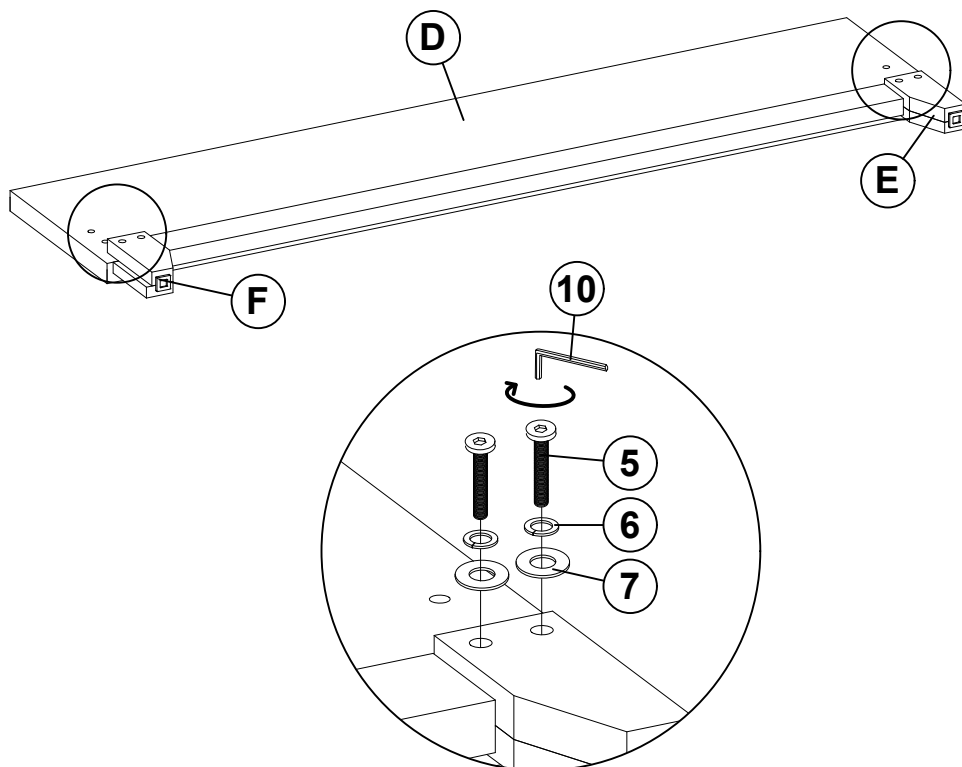

**** BACK VIEW**

ITEM: **223441Q (B1&B2)**

ASSEMBLY INSTRUCTIONS

STEP 3

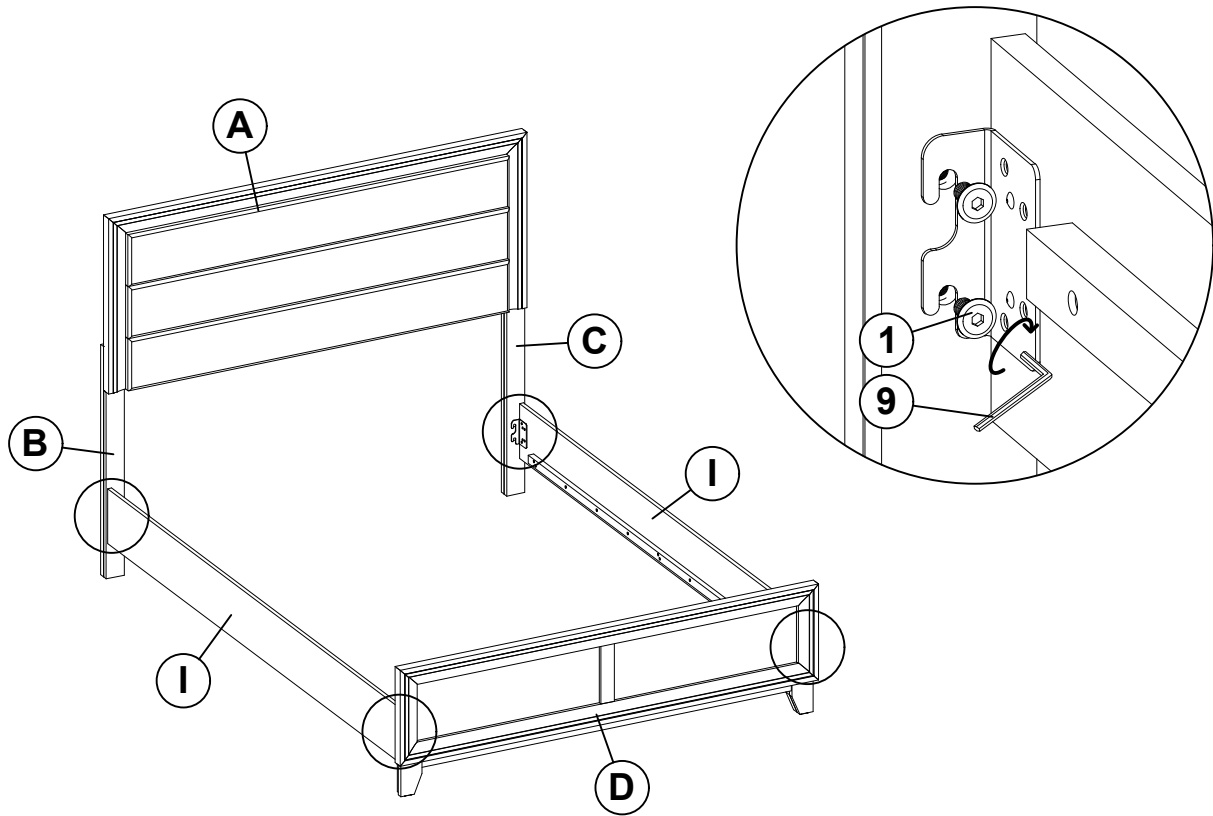

STEP 4

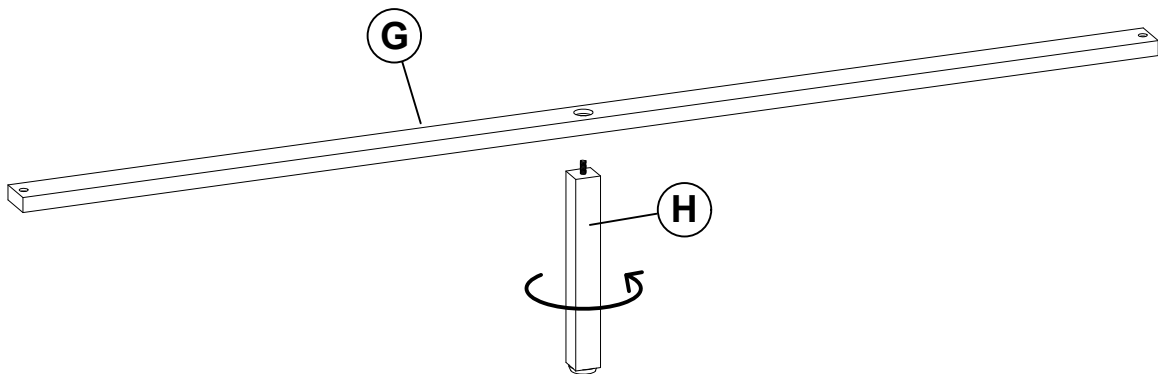

ITEM: **223441Q (B1&B2)**

ASSEMBLY INSTRUCTIONS



STEP 5

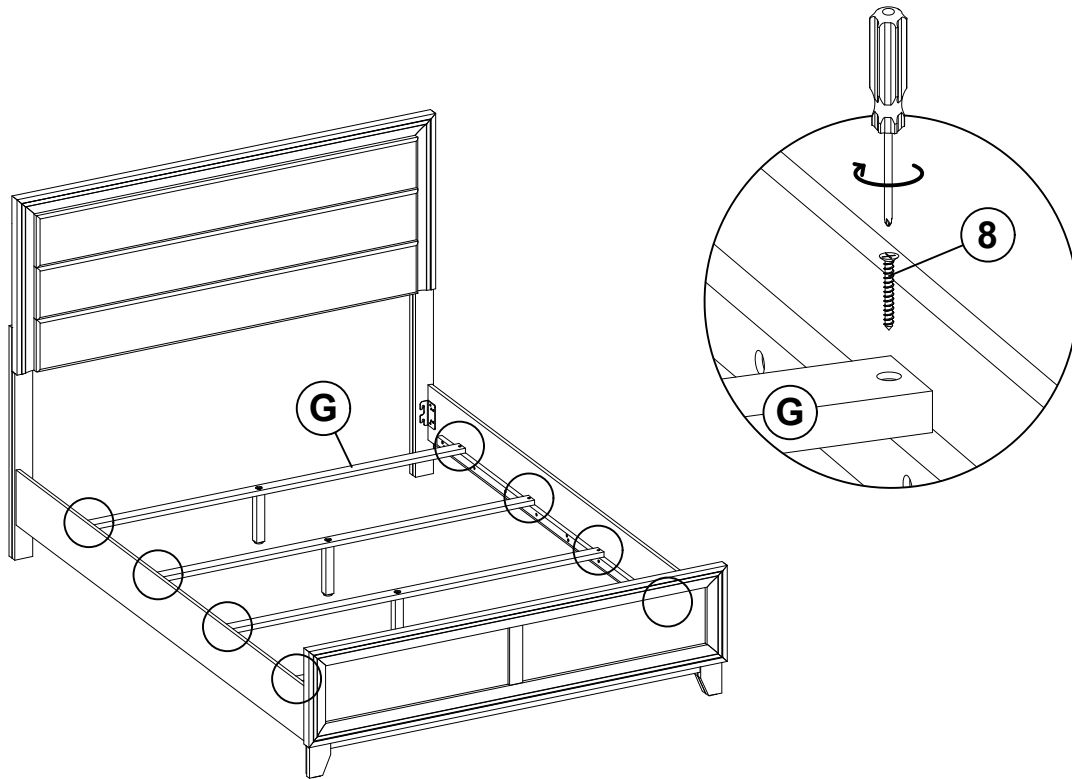

STEP 6
COMPLETE

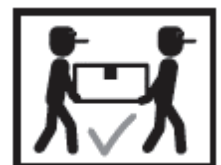
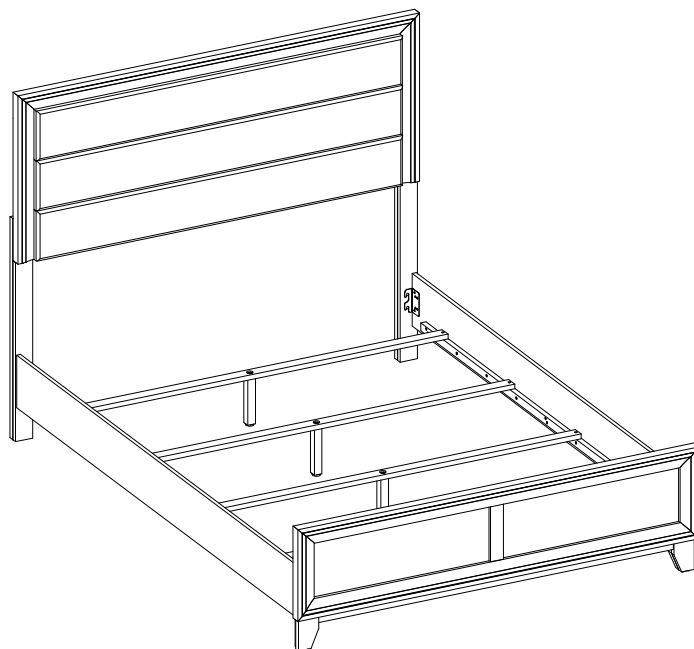

ITEM: **223441Q (B1&B2)**



Inner Size : 60.75"W X 81.00"D

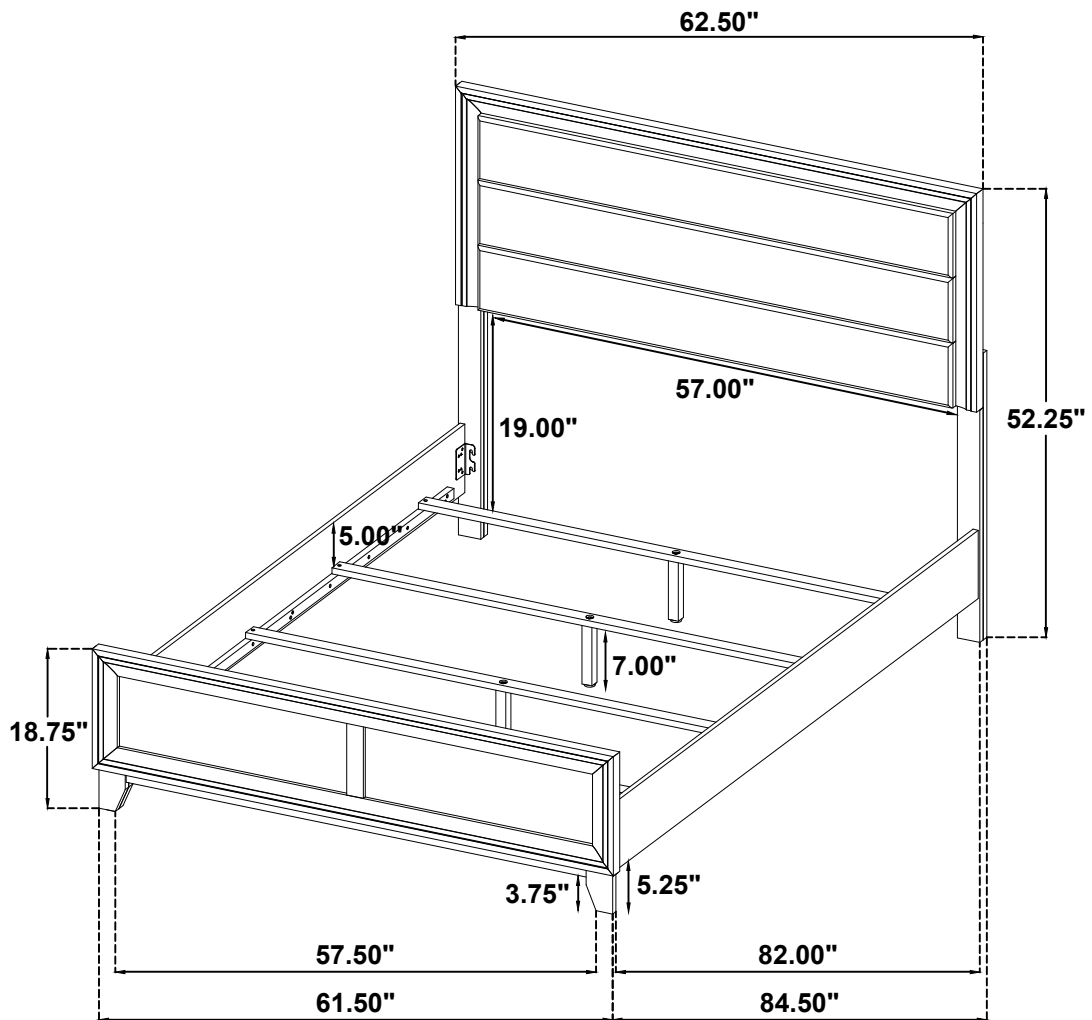

Note : Dimension tolerance $\pm 5\%$