

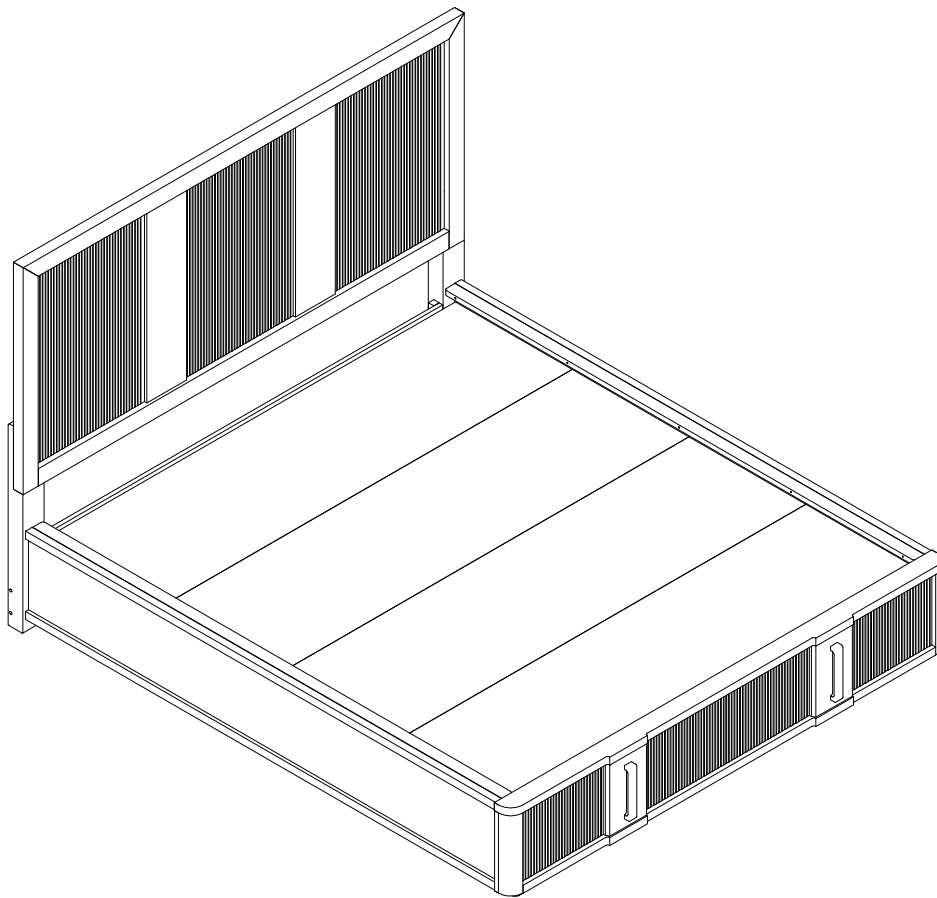

**ASSEMBLY INSTRUCTIONS**  
**COASTER FINE FURNITURE**



*Fine Furniture for every stage of life*

**224900KW (B1-B3)**  
**California King Bed**

# ITEM: 224900KW(B1-B3)



## ASSEMBLY INSTRUCTIONS

### ASSEMBLY TIPS:

- 1.Remove hardware from box and sort by size.
- 2.Please check to see that all hardware and parts are present prior to start of assembly.
- 3.Please follow attached instructions in the same sequence as numbered to assure fast & easy assembly.



### WARNING

- 1.Don't attempt to repair or modify parts that are broken or defective. Please contact the store immediately.
- 2.This product is for home use only and not intended for commercial establishments.



ASSEMBLY TIME

20 MINUTES

## PARTS IDENTIFICATION

### B1 (BOX 1)

A HEADBOARD PANEL

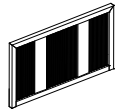

1PC

B LEFT HEADBOARD LEG



1PC

C RIGHT HEADBOARD LEG



1PC

D HEADBOARD BOTTOM RAIL

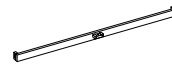

1PC

### B2 (BOX 2)

E STORAGE FOOTBOARD

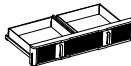

1PC

F ROLL SLAT (13PCS)

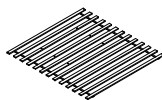

1SET

G CENTER RAIL SUPPORT WITH LEVELER



3PCS

H BED SLAT SUPPORT WITH LEVELER



6PCS

I CONCEAL PANEL



4PCS

### B3 (BOX 3)

J BED RAIL

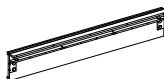

2PCS

K CENTER RAIL



1PC

HB 224900KW (B1) FROM BOX 1 HEADBOARD COMPLETE

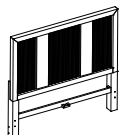

1PC

E 224900KW (B2) FROM BOX 2 FOOTBOARD

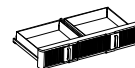

1PC

# ITEM: 224900KW(B1-B3)



## ASSEMBLY INSTRUCTIONS

### ASSEMBLY TIPS:

1. Remove hardware from box and sort by size.
2. Please check to see that all hardware and parts are present prior to start of assembly.
3. Please follow attached instructions in the same sequence as numbered to assure fast & easy assembly.







### WARNING

1. Don't attempt to repair or modify parts that are broken or defective. Please contact the store immediately.
2. This product is for home use only and not intended for commercial establishments.

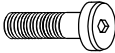
## HARDWARE IDENTIFICATION







### Z-B1 (BOX 1) - HARDWARE PACK IS LOCATED IN 224900KW (B1)

1	<b>BOLT</b> (5/16" x 38mm - RBW)		12PCS	3	<b>FLAT WASHER</b> (5/16" x 19 x 1.5mm - RBW)		12PCS
2	<b>LOCK WASHER</b> (5/16" - RBW)		12PCS	4	<b>ALLEN WRENCH</b> (74 x 30 x 4mm - RBW)		1PC

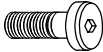
### Z-B2 (BOX 2) - HARDWARE PACK IS LOCATED IN 224900KW (B2)

5	<b>FLAT HEAD SCREW</b> (4 x 32mm - RBW)		6PCS
---	--	---	------

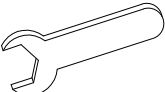
### Z-B3 (BOX 3) - HARDWARE PACK IS LOCATED IN 224900KW (B3)

6	<b>THREADED BOLT</b> (5/16" x 75mm - RBW)		8PCS	10	<b>BOLT</b> (1/4 x 25mm - RBW)		2PCS
7	<b>U-SQUARE WASHER</b> (25 x 15 x 2mm - RBW)		8PCS	11	<b>LOCK WASHER</b> (1/4" - RBW)		2PCS
8	<b>HEX NUT</b> (5/16" x 17mm - RBW)		8PCS	12	<b>FLAT WASHER</b> (1/4" x 19 x 1.5mm - RBW)		2PCS
9	<b>WRENCH</b> (13MM - RBW)		1PC	13	<b>ALLEN WRENCH</b> (74 x 30 x 4mm - RBW)		1PC

### NOTE:

Phillips head screw driver is required in the assembly process; however, manufacturer does not provide this item.

# ITEM: 224900KW(B1-B3)

## ASSEMBLY INSTRUCTIONS



### STEP 1

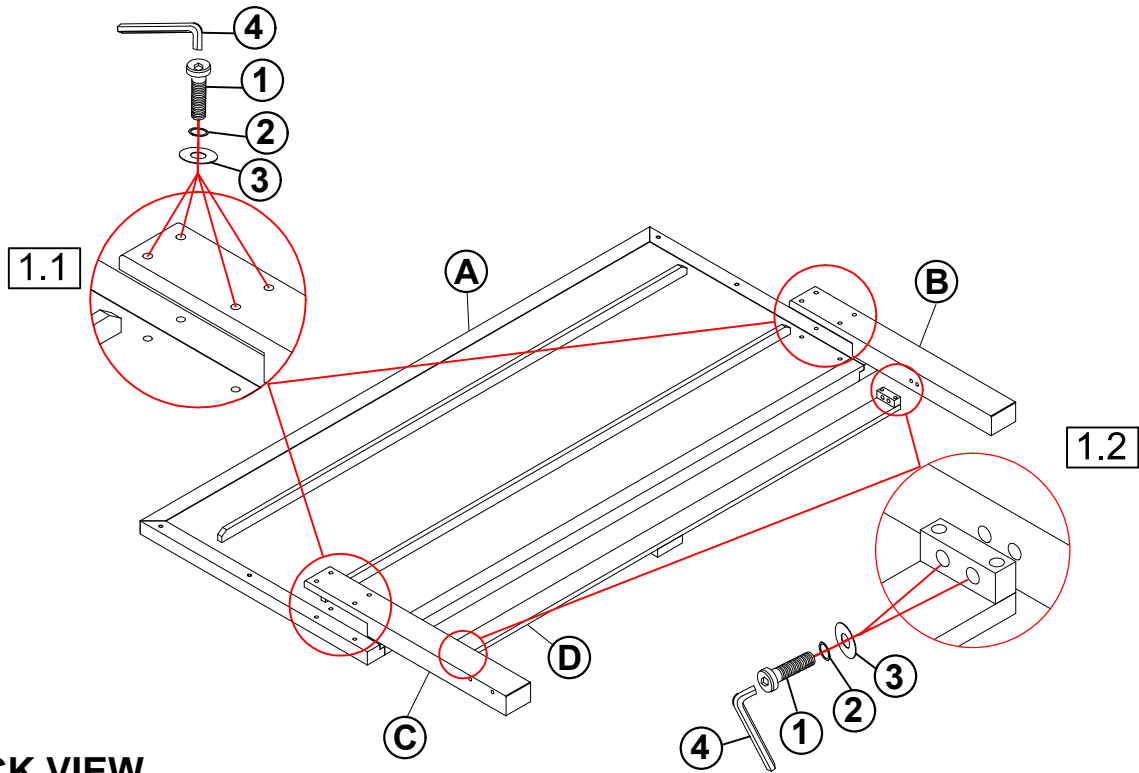

\* BACK VIEW

### STEP 2

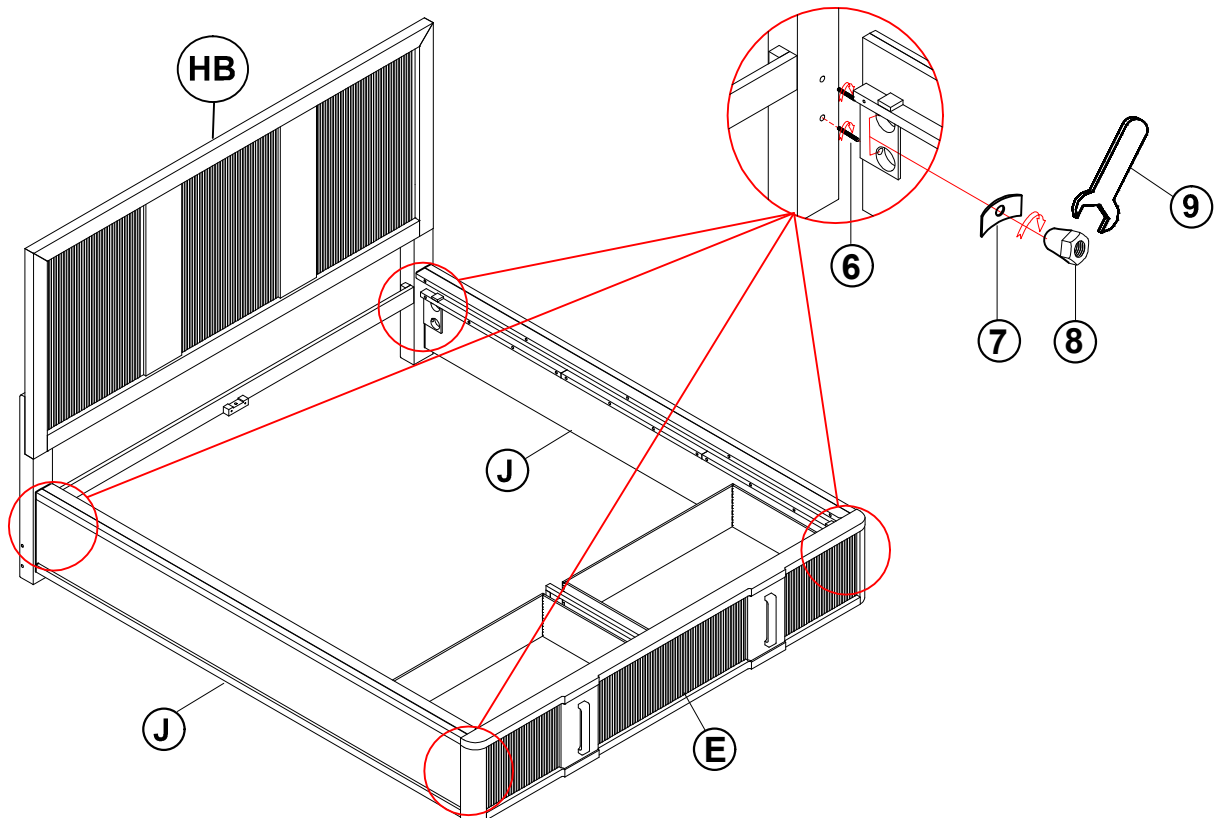

# ITEM: 224900KW(B1-B3)

## ASSEMBLY INSTRUCTIONS

### STEP 3

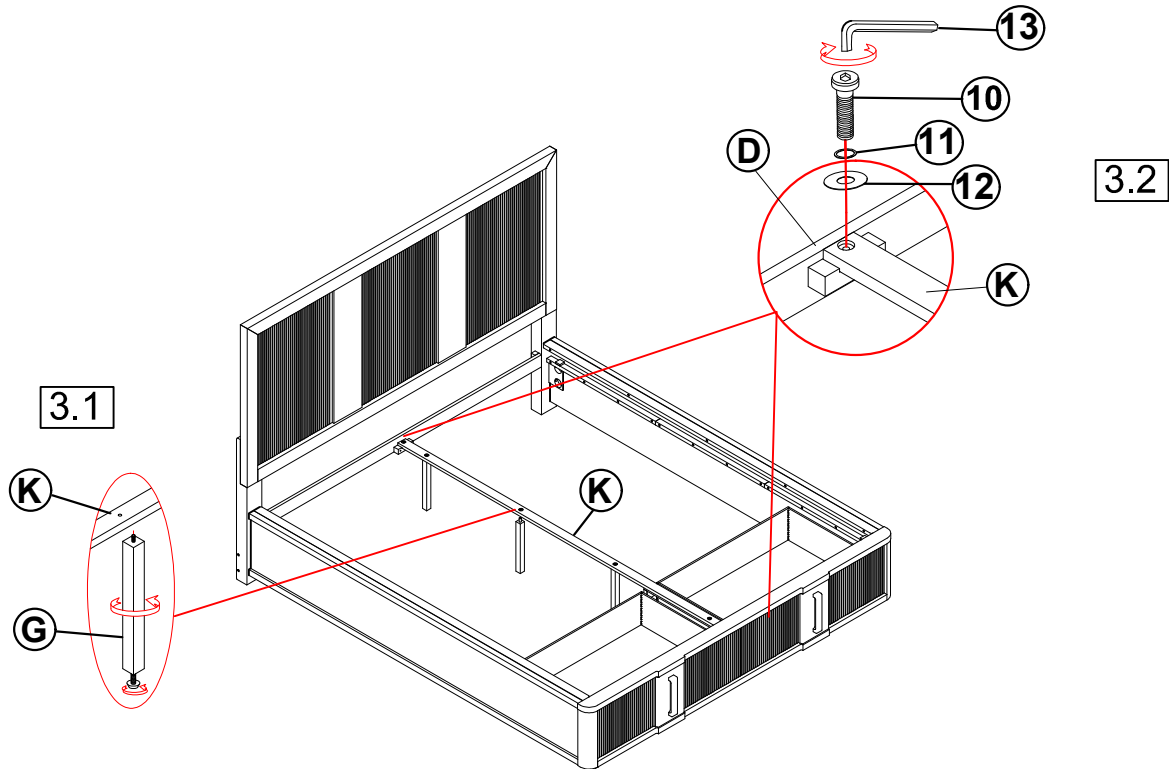

### STEP 4

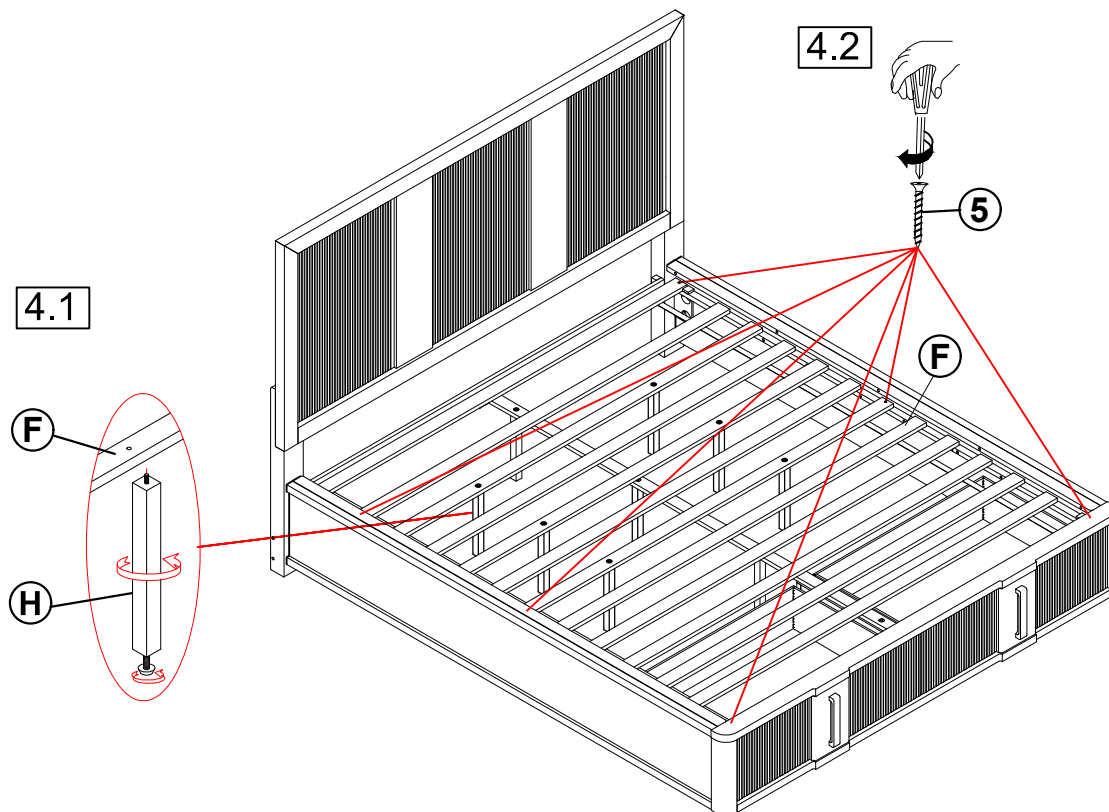

ITEM: **224900KW(B1-B3)**

**ASSEMBLY INSTRUCTIONS**



**STEP 5**

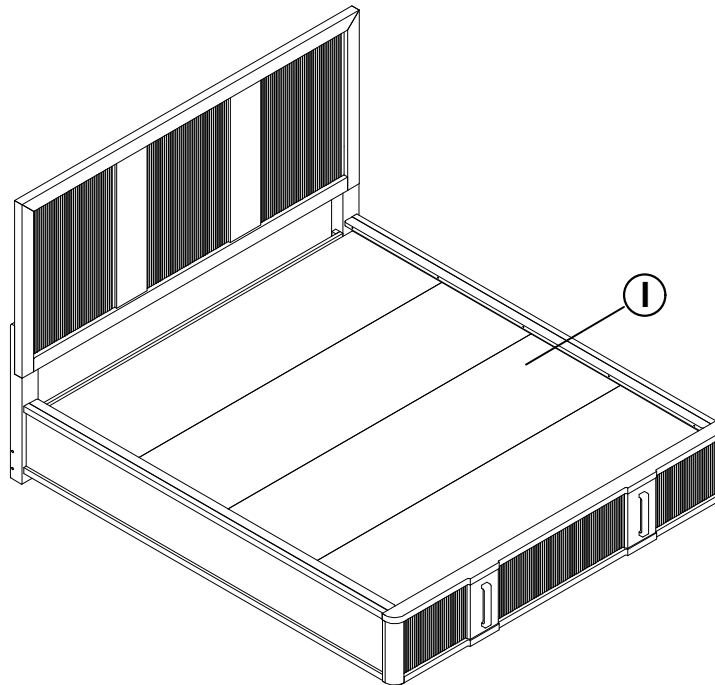

**STEP 6**

**COMPLETE**

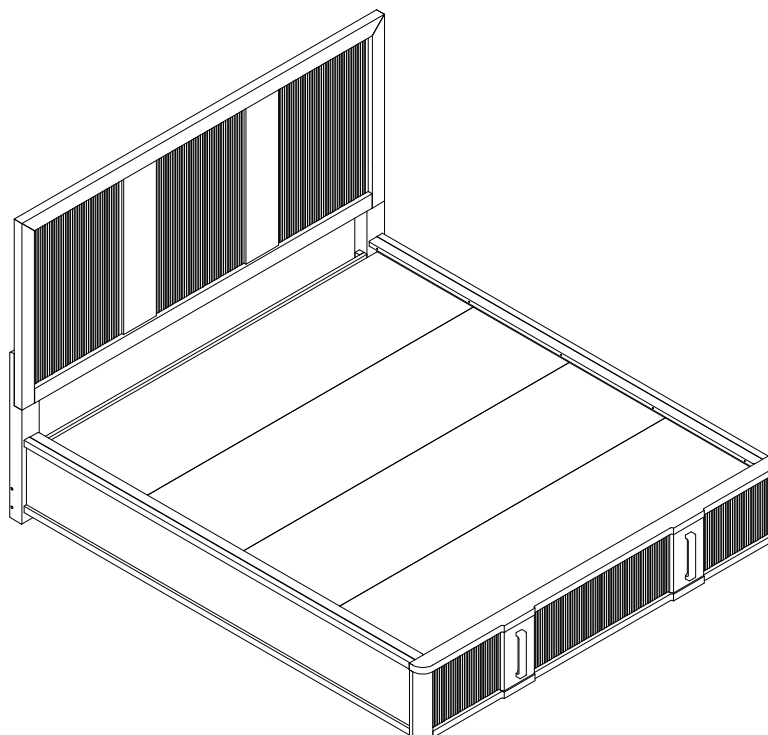

# ITEM: 224900KW(B1-B3)



Inner Size : 86.00"W x 77.25"D

Inner Size of Drawer : 33.75"W x 22.75"D x 7.25"H x 0.25T

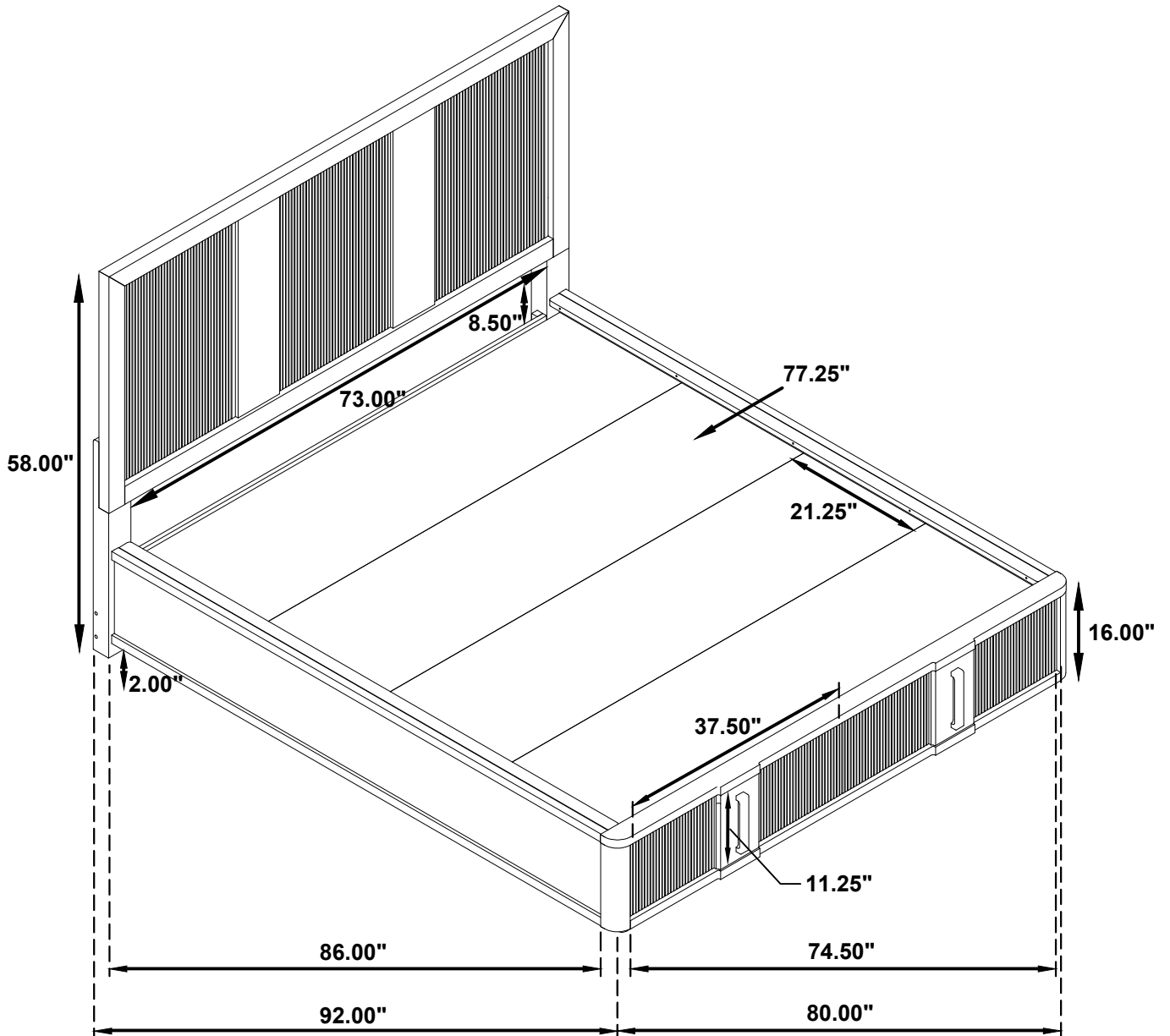

Note : Dimension tolerance  $\pm 5\%$