

ASSEMBLY INSTRUCTIONS
COASTER FINE FURNITURE



Fine Furniture for every stage of life

701024
TV CONSOLE

ITEM: 701024



ASSEMBLY INSTRUCTIONS

ASSEMBLY TIPS:

1. Remove hardware from box and sort by size.
2. Please check to see that all hardware and parts are present prior to start of assembly.
3. Please follow attached instructions in the same sequence as numbered to assure fast & easy assembly.



WARNING!

1. Don't attempt to repair or modify parts that are broken or defective. Please contact the store immediately.
2. This product is for home use only and not intended for commercial establishments.



ASSEMBLY TIME

40 MINUTES

MAX TV SIZE: 65"

PARTS IDENTIFICATION

A LEFT SIDE PANEL

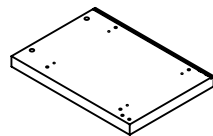

1 PC

B RIGHT SIDE PANEL

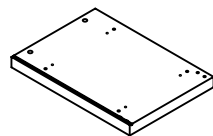

1 PC

C LEFT DIVIDE PANEL

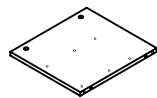

1 PC

D RIGHT DIVIDE PANEL

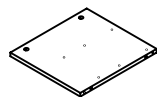

1 PC

E BOTTOM PANEL

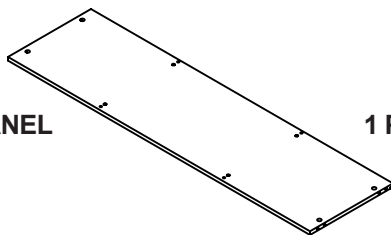

1 PC

F CROSS BRACE

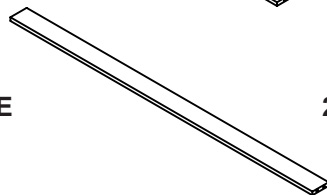

2 PCS

G CROSS PANEL

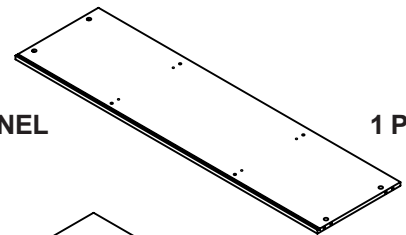

1 PC

H TOP PANEL

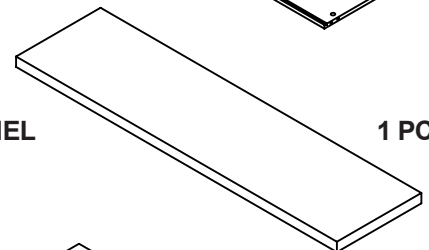

1 PC

I UPPER BACK PANEL

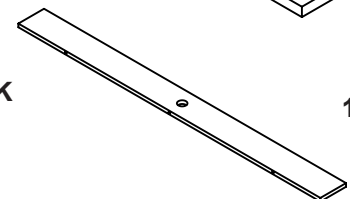

1 PC

J DOWN BACK PANEL

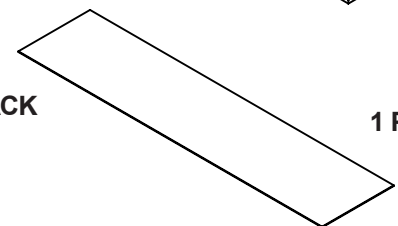

1 PC

K DRAWER FRONT PANEL

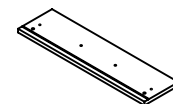

2 PCS

L DRAWER BACK PANEL

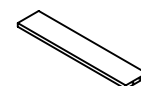

2 PCS

NOTE:

Phillips head screw driver is required in the assembly process; however, manufacturer does not provide this item.











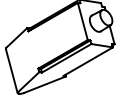

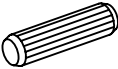
ITEM: 701024

M LEFT DRAWER SIDE PANEL  2 PCS

O DRAWER BOTTOM PANEL  2 PCS

N RIGHT DRAWER SIDE PANEL  2 PCS

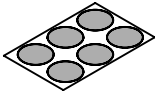
Z HARDWARE IDENTIFICATION

NO	DESCRIPTION	FIGURE	Q'TY	NO	DESCRIPTION	FIGURE	Q'TY
1	GLUE 40g		1 PC	8	GLIDES L = 350mm		2 SET
2	WOODEN DOWEL Ø 8x30mm		42 PCS	9	GLIDES SCREW Ø 3x12mm		24 PCS
3	CAM BOLT Ø 7x35.5mm		20 PCS	10	HANDLE		2 PCS
4	CAM LOCK Ø15x12mm		20 PCS	11	HANDLE BOLT M5x25mm		4 PCS
5	SCREW Ø 4.5x42mm		4 PCS	12	NUT M5		4 PCS
6	DRAWER SCREW Ø 4.3x35mm		8 PCS	13	STICKER Ø 20mm		4 PCS
7	PLASTIC FEET Ø 15mm		6 PCS				

Z8,Z10,Z11,Z12 not included in blister packaging.

NOTE:

Phillips head screw driver is required in the assembly process; however, manufacturer does not provide this item.

ITEM: 701024

STEP 1

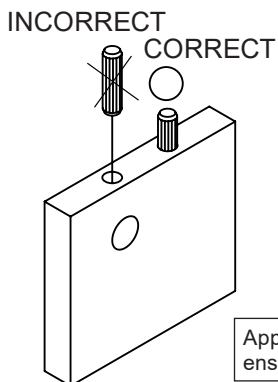
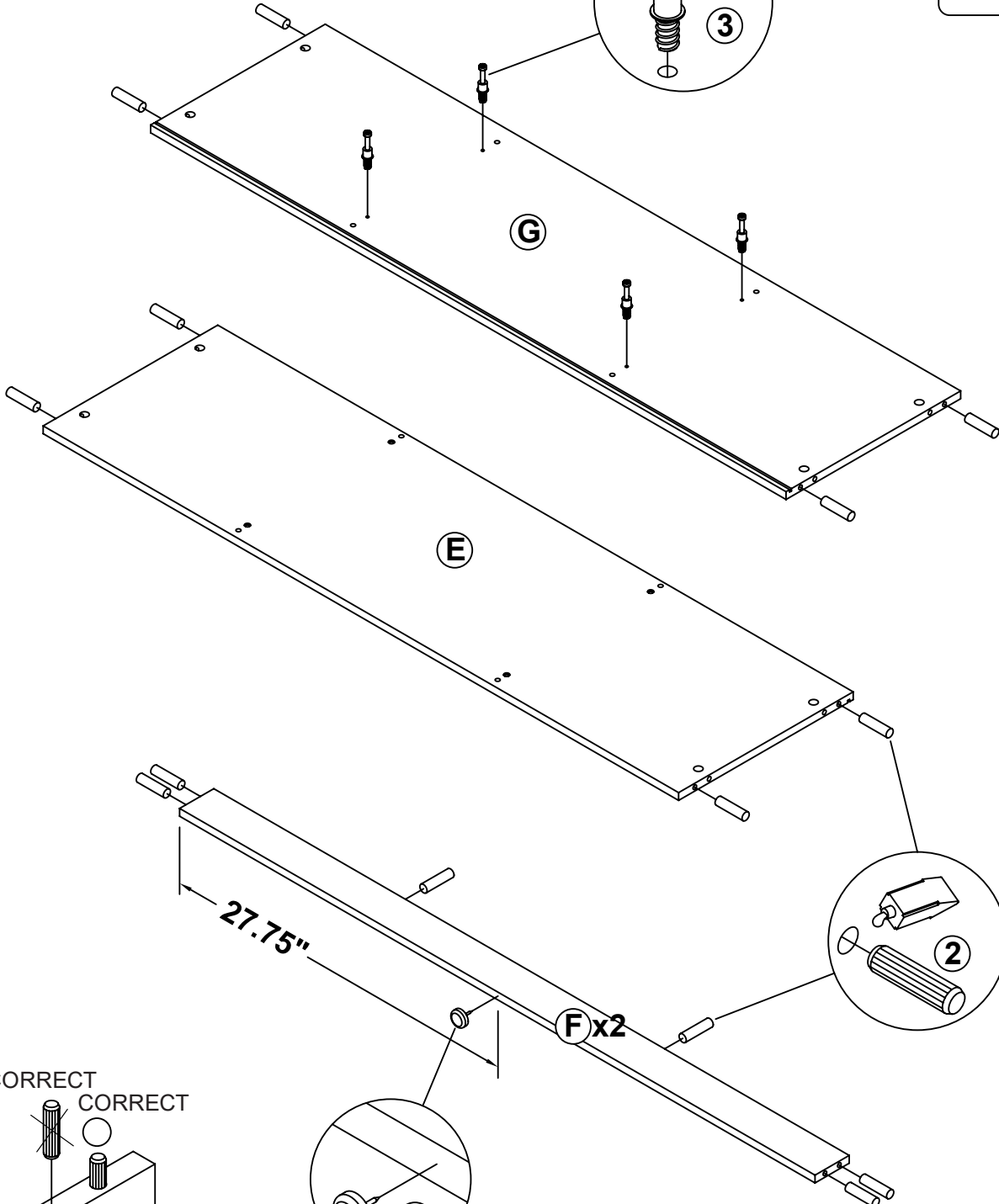
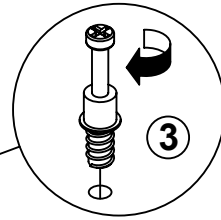
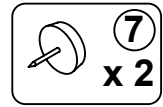
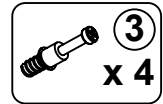
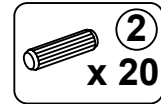

Apply glue on all wooden dowels to ensure integrity of the structure.

ITEM: 701024

STEP 2

Apply glue on all wooden dowels to ensure integrity of the structure.

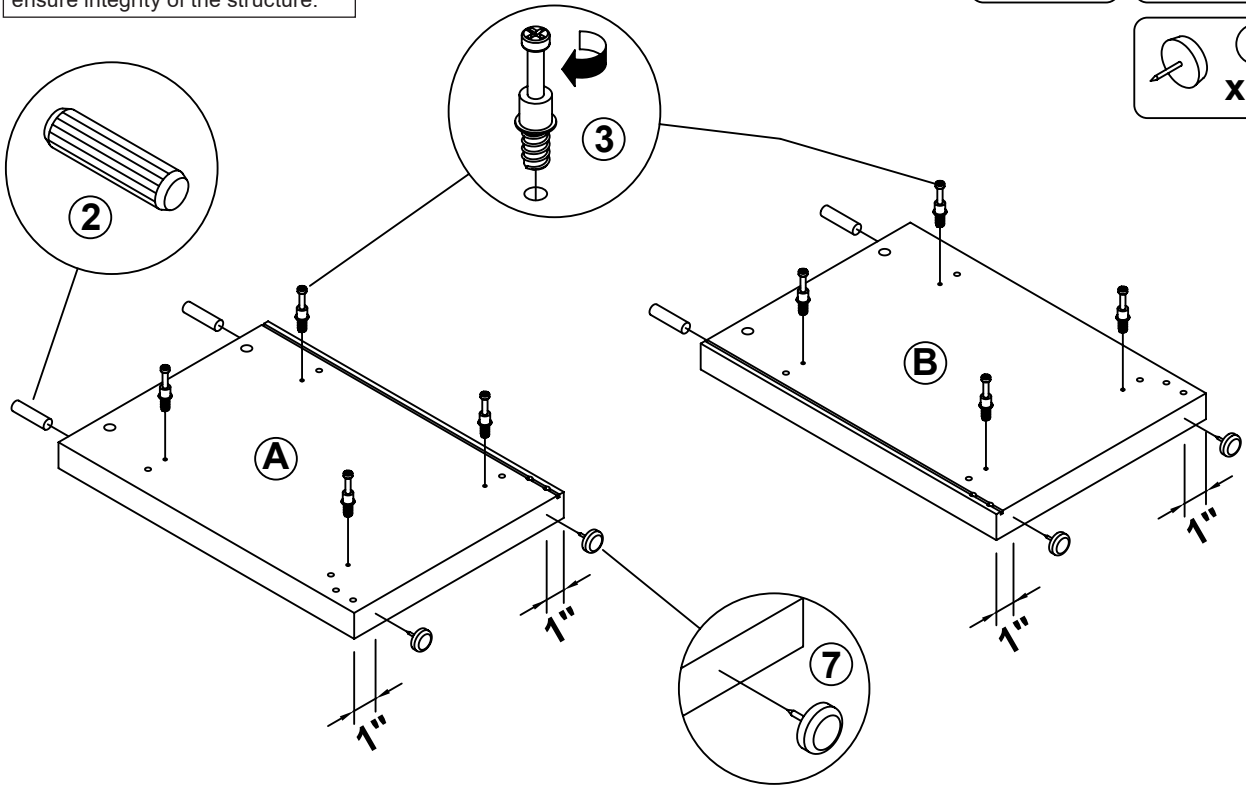
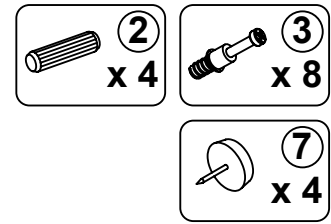

STEP 3

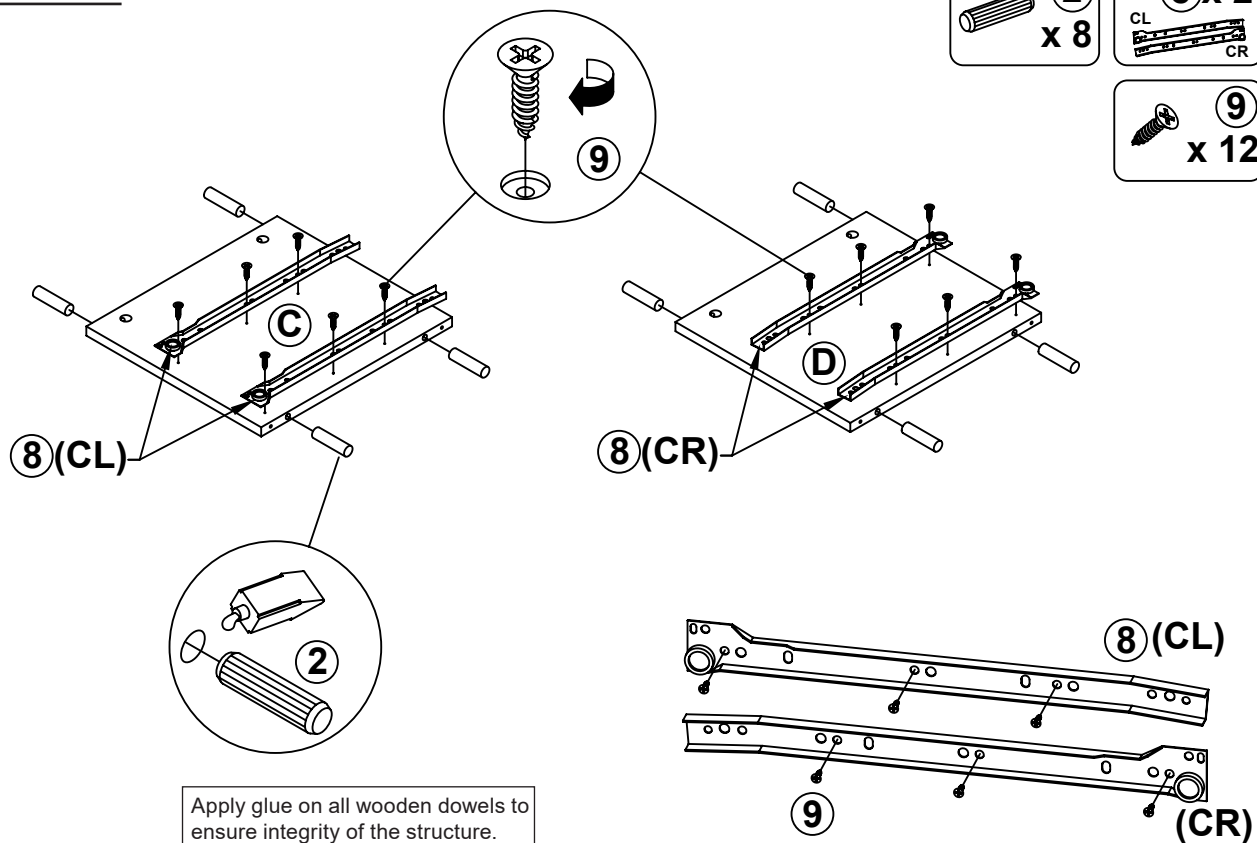
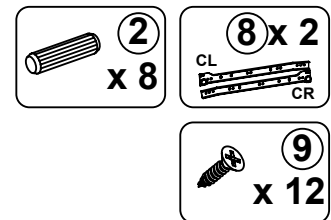

Apply glue on all wooden dowels to ensure integrity of the structure.

ITEM: 701024

STEP 4

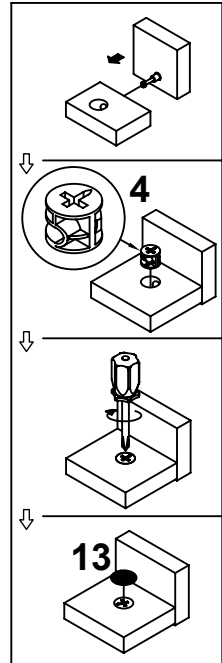
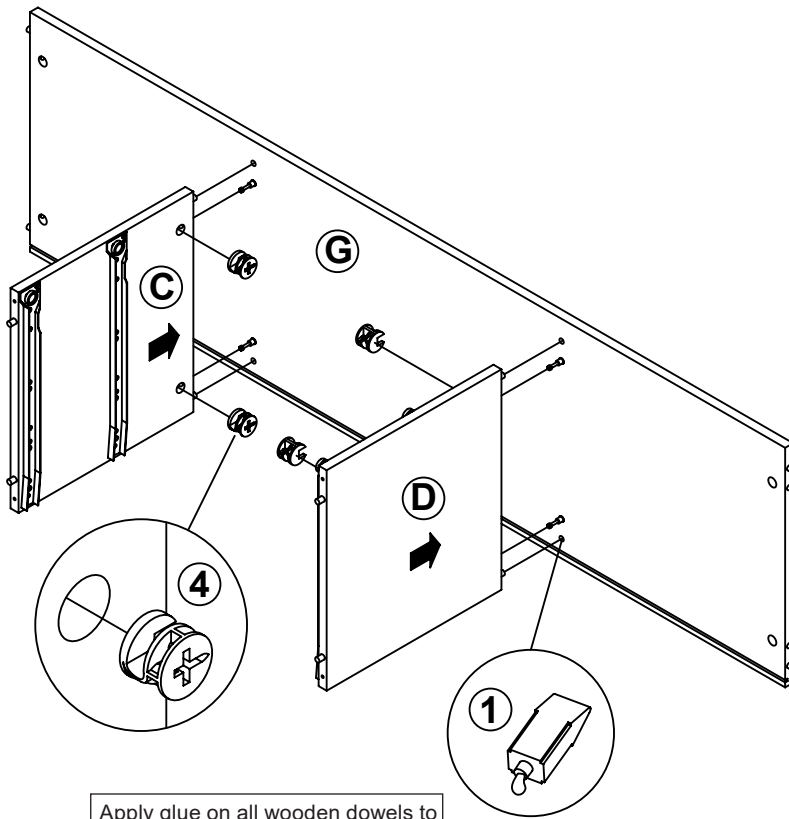
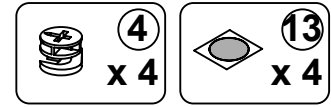

Apply glue on all wooden dowels to ensure integrity of the structure.

STEP 5

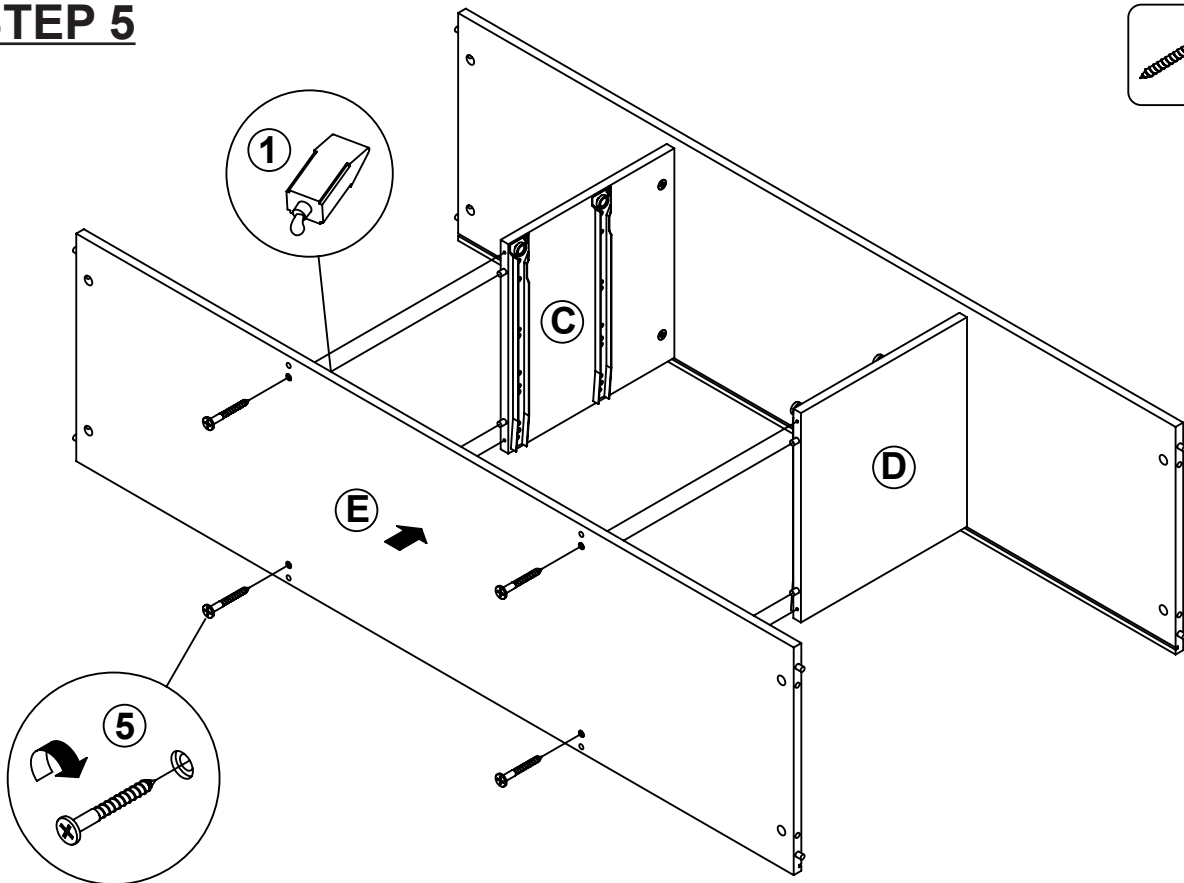
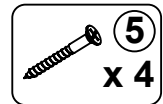

ITEM: 701024

STEP 6

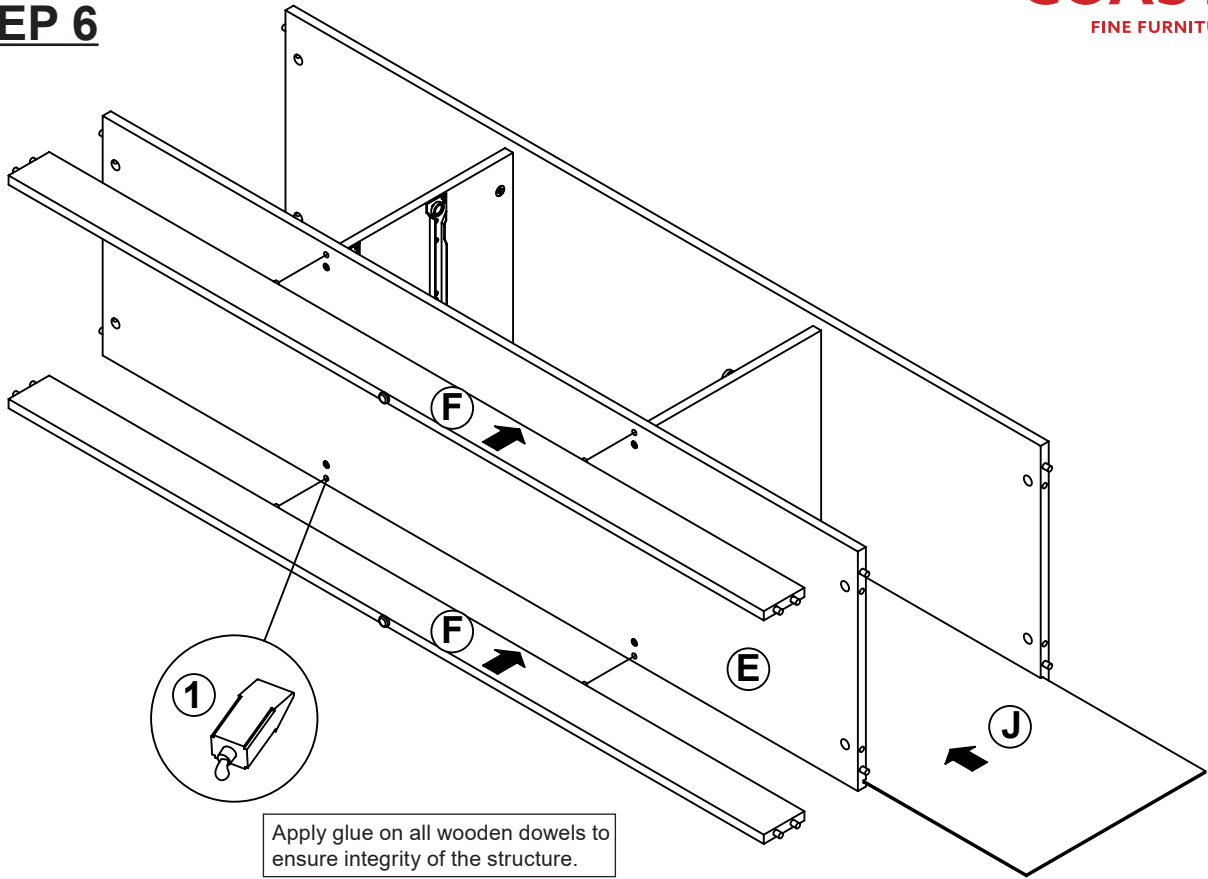

Apply glue on all wooden dowels to ensure integrity of the structure.

STEP 7

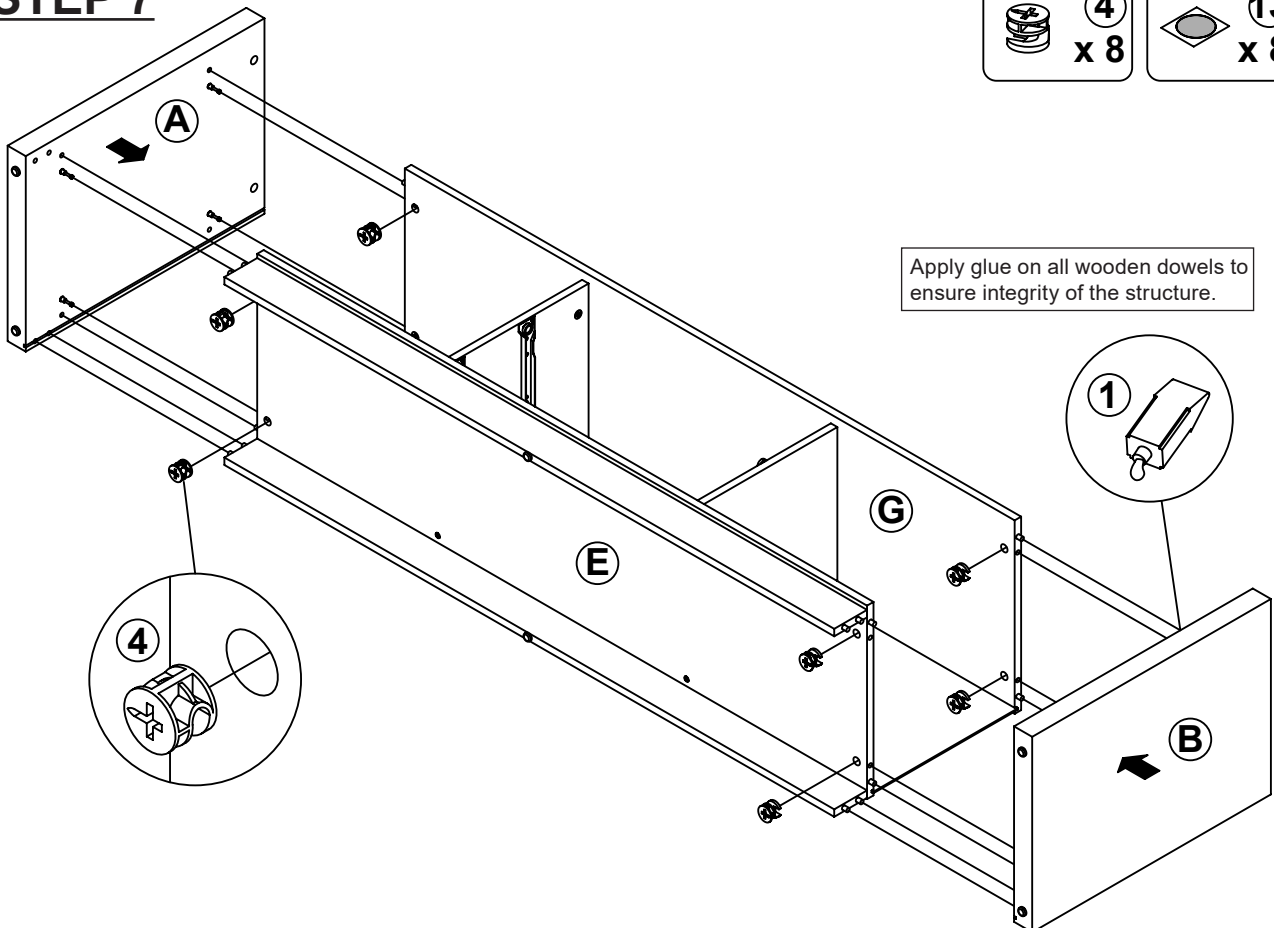
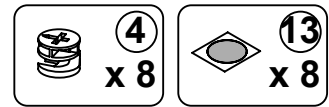

Apply glue on all wooden dowels to ensure integrity of the structure.

ITEM: 701024

STEP 8

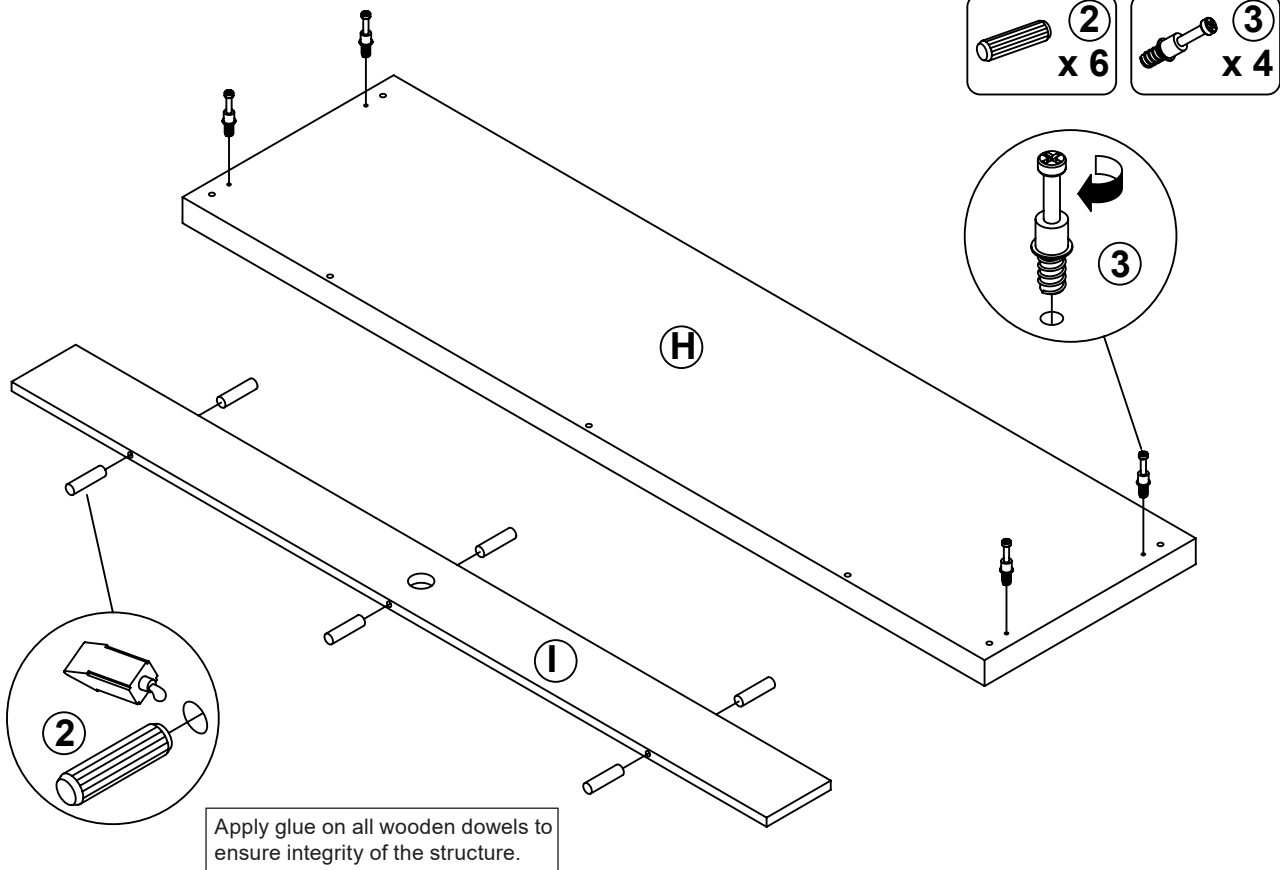

STEP 9

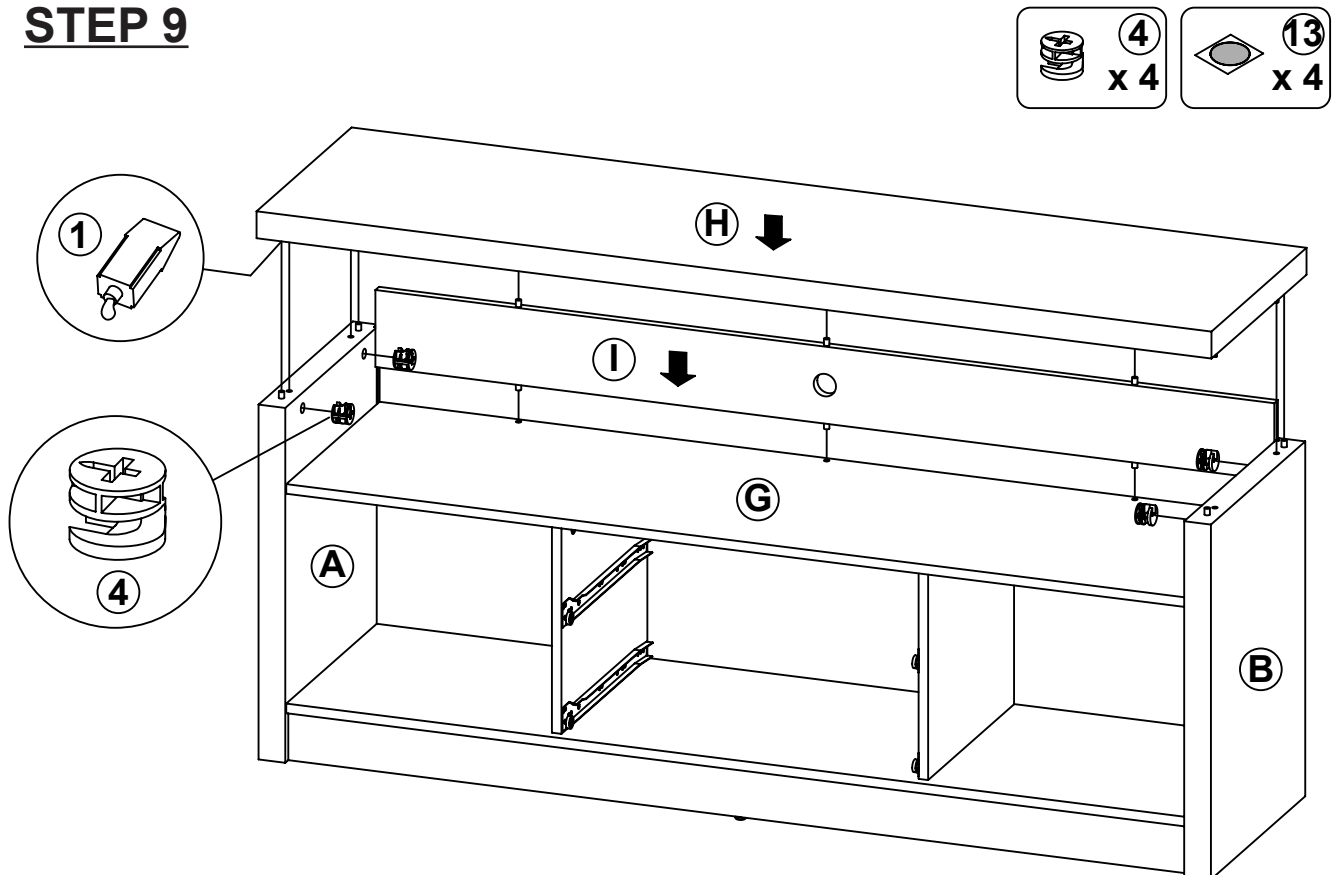

ITEM: 701024

STEP 10-1

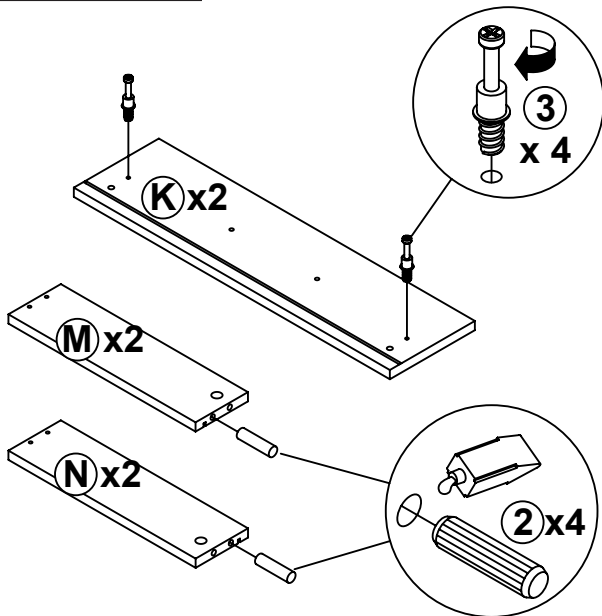

STEP 10-2

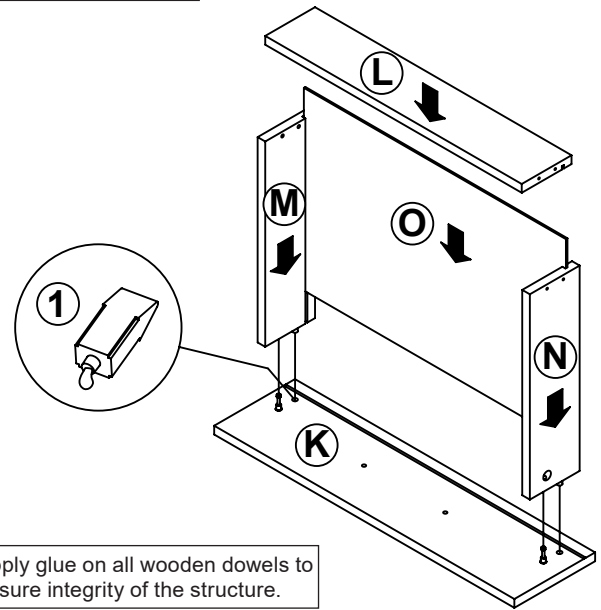

Apply glue on all wooden dowels to ensure integrity of the structure.

STEP 10-3

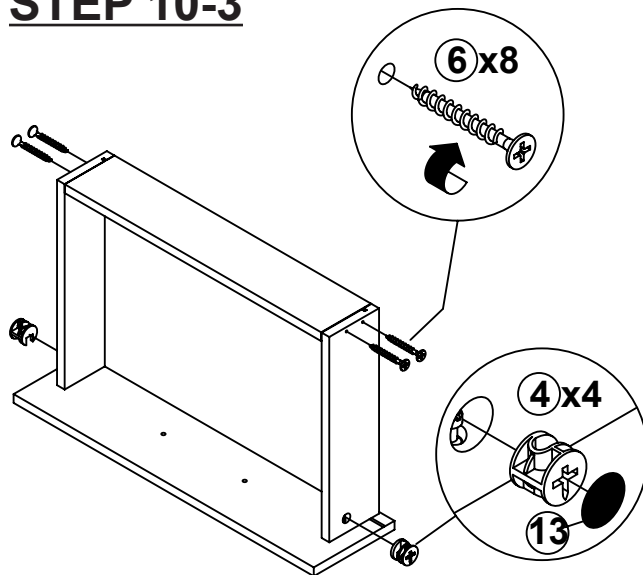

STEP 10-4

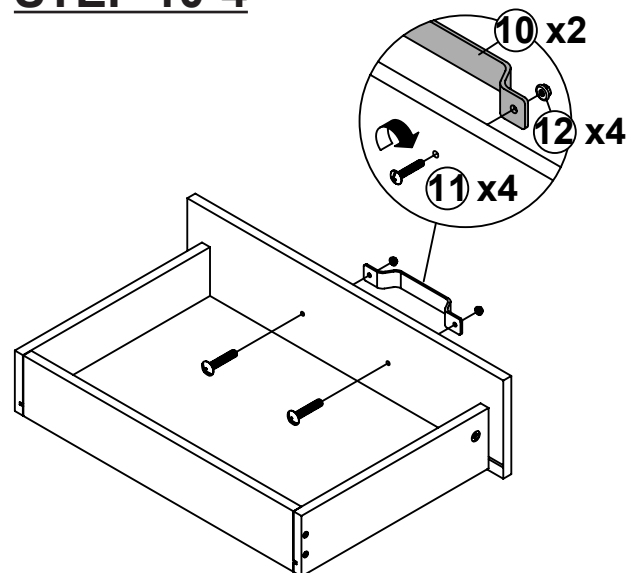

STEP 10-5

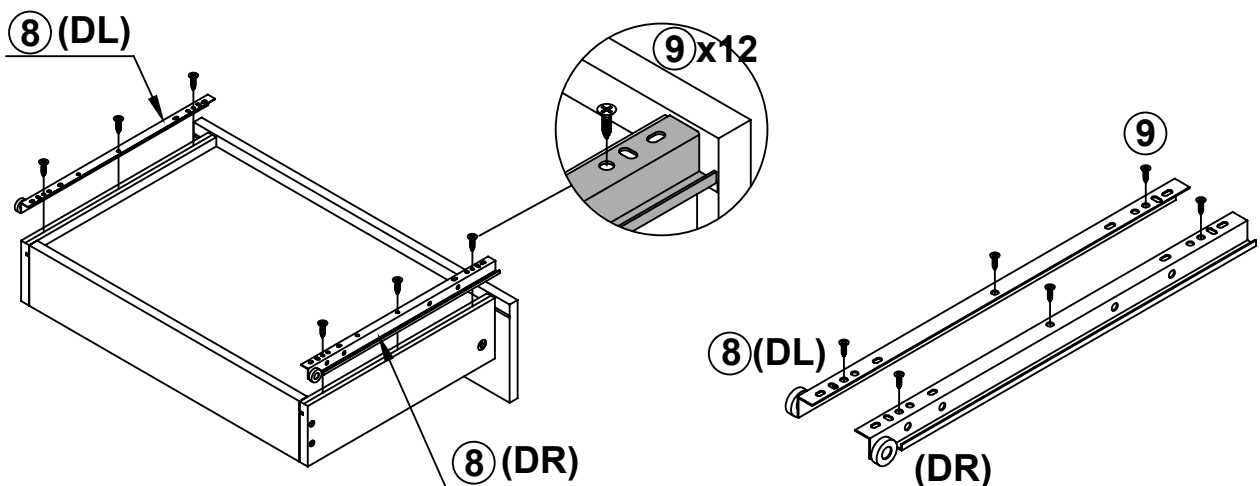

ITEM: 701024

STEP 11

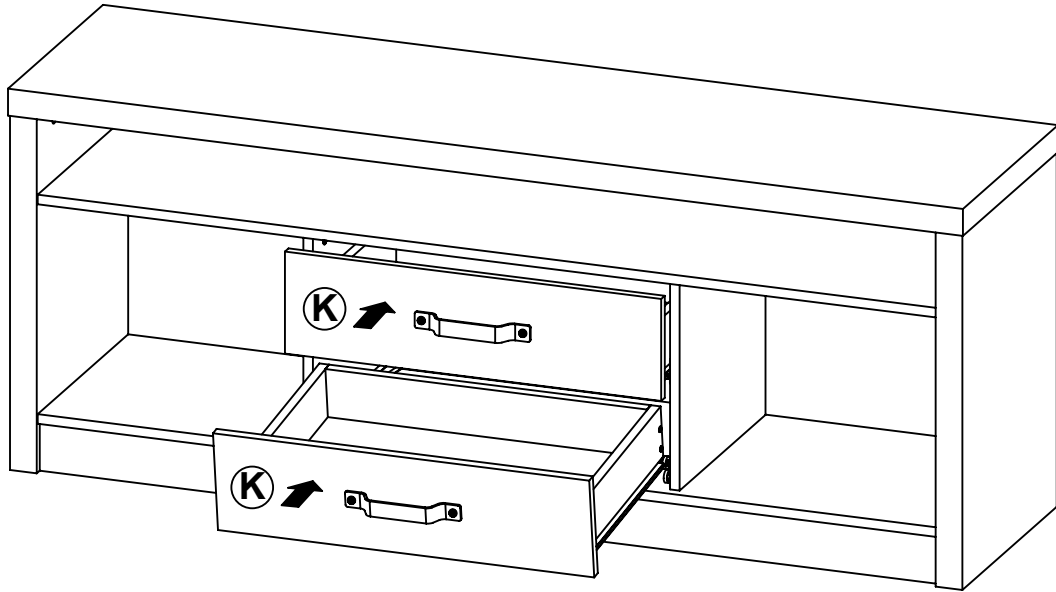

STEP 12

COMPLETE

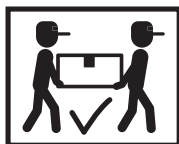
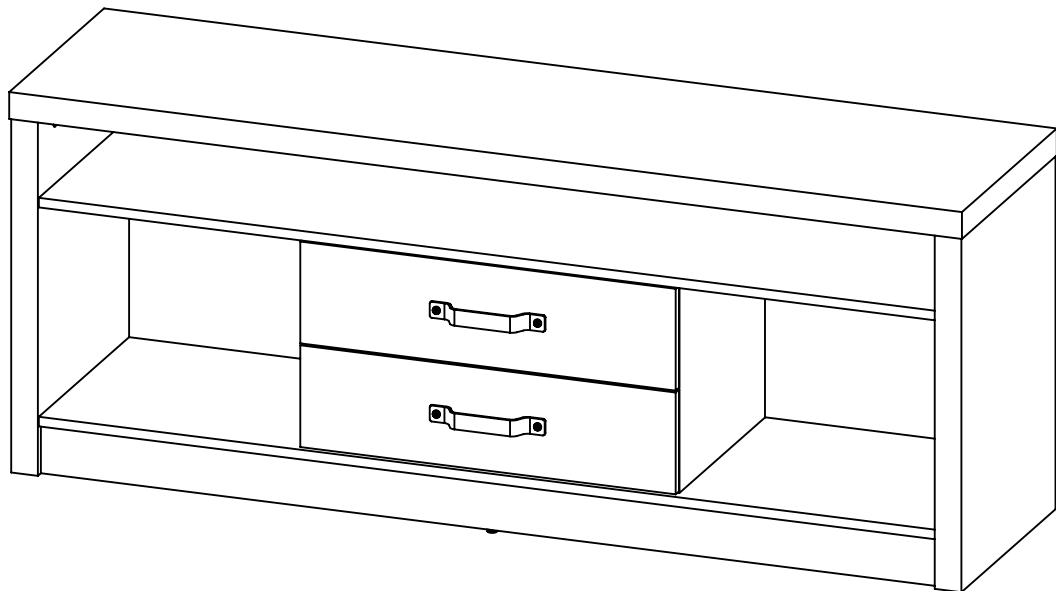

ITEM: 701024

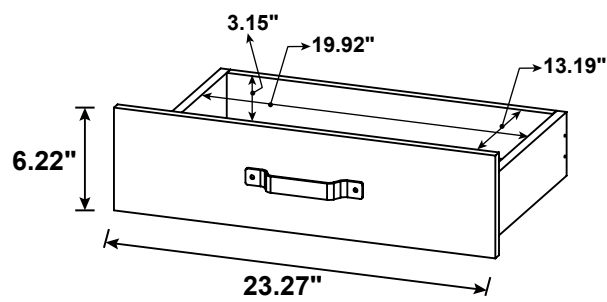
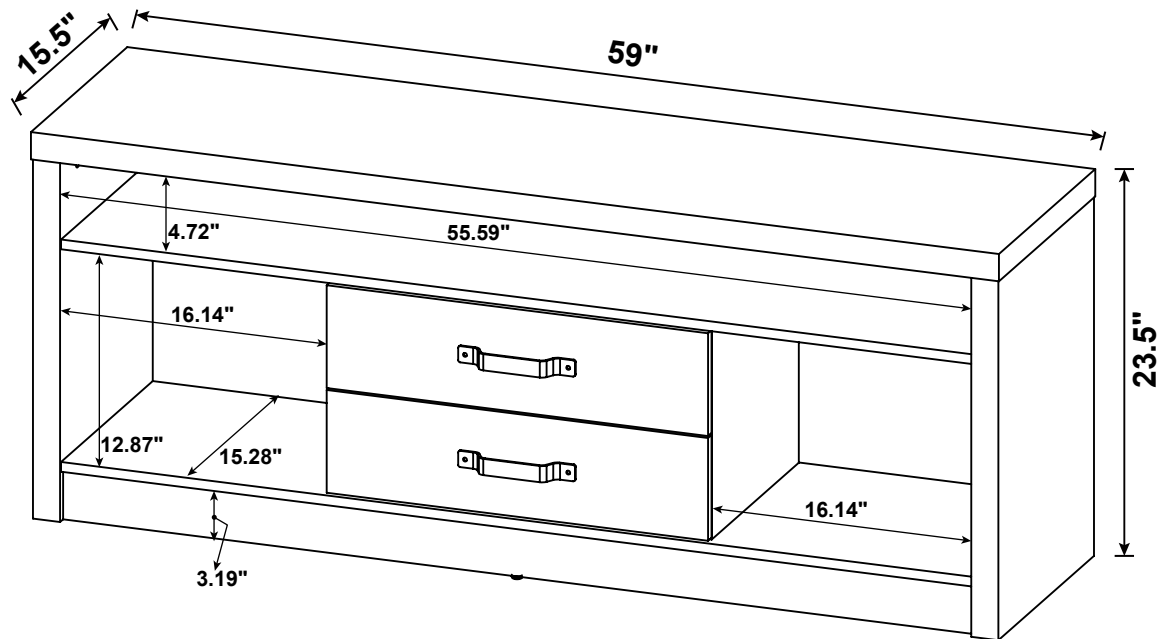

Note : Dimension tolerance $\pm 5\%$

ASSEMBLY INSTRUCTIONS
COASTER FINE FURNITURE



Fine Furniture for every stage of life

707726
MEDIA TOWER

ITEM: 707726



ASSEMBLY INSTRUCTIONS

ASSEMBLY TIPS:

1. Remove hardware from box and sort by size.
2. Please check to see that all hardware and parts are present prior to start of assembly.
3. Please follow attached instructions in the same sequence as numbered to assure fast & easy assembly.



WARNING!

1. Don't attempt to repair or modify parts that are broken or defective. Please contact the store immediately.
2. This product is for home use only and not intended for commercial establishments.

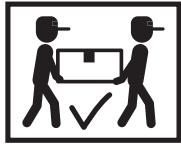

ASSEMBLY TIME

40 MINUTES











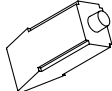

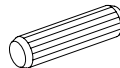
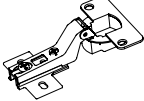
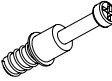
PARTS IDENTIFICATION

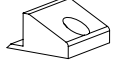
A	LEFT SIDE PANEL		1 PC	G	UPPER CROSS PANEL		2 PCS
B	RIGHT SIDE PANEL		1 PC	H	TOP PANEL		1 PC
C	FRONT CROSS BRACE		1 PC	I	UPPER BACK PANEL		3 PCS
D	BOTTOM PANEL		1 PC	JN	LOWER BACK PANEL		1 PC
E	ADJUSTABLE SHELF		1 PC	K	DOOR		1 PC
F	LOWER CROSS PANEL		1 PC	L	BACK CROSS BRACE		1 PC

NOTE:

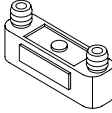
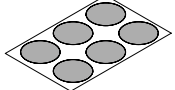
Phillips head screw driver is required in the assembly process; however, manufacturer does not provide this item.

HARDWARE IDENTIFICATION

Z							
NO	DESCRIPTION	FIGURE	Q'TY	NO	DESCRIPTION	FIGURE	Q'TY
1	GLUE 40g		1 PC	10	NUT M5		2 PCS
2	WOODEN DOWEL ø8x30mm		28 PCS	11	HINGE ø35mm SR		2 PCS
3	CAM BOLT ø7x35.5mm SR		16 PCS	12	HINGE SCREW ø4x15mm SR		8 PCS
4	CAM LOCK ø15x12mm SR		16 PCS	13	FIXER		6 PCS
5	PLASTIC FEET Ø15mm		4 PCS	14	FIXER SCREW ø3x19mm SR		6 PCS
6	PIN FOR ADJUSTABLE SHELF ø4.9x8mm SR		4 PCS	15	SCREW Ø4.5x42mm SR		4 PCS
7	DOOR CATCH		1 PC	16	STICKER ø20mm		3 PCS
8	HANDLE BLK		1 PC	17	PLASTIC COVER Ø 52mm		1 PC
9	HANDLE BOLT M5x25mm BLK		2 PCS				

Z8,Z9,Z10,Z11 not included in blister packaging.

NOTE:

Phillips head screw driver is required in the assembly process; however, manufacturer does not provide this item.

ITEM: 707726

COASTER[®]

FINE FURNITURE

STEP 1

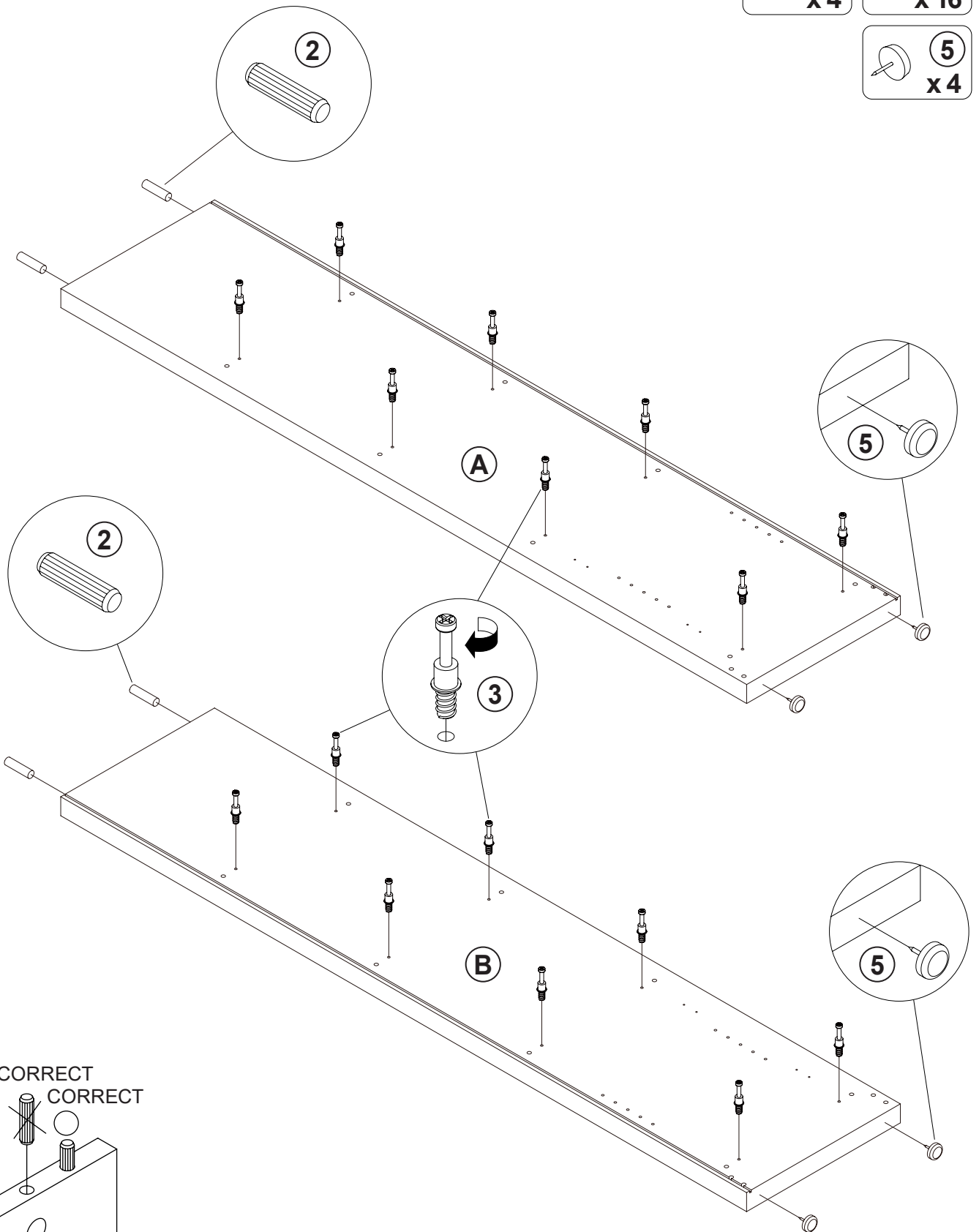
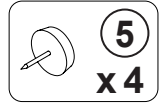
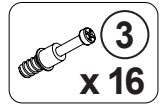
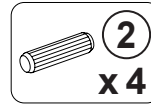

INCORRECT
CORRECT

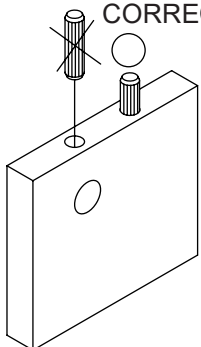

Apply glue on all wooden dowels to ensure integrity of the structure.

ITEM: 707726

COASTER[®]

FINE FURNITURE

STEP 2

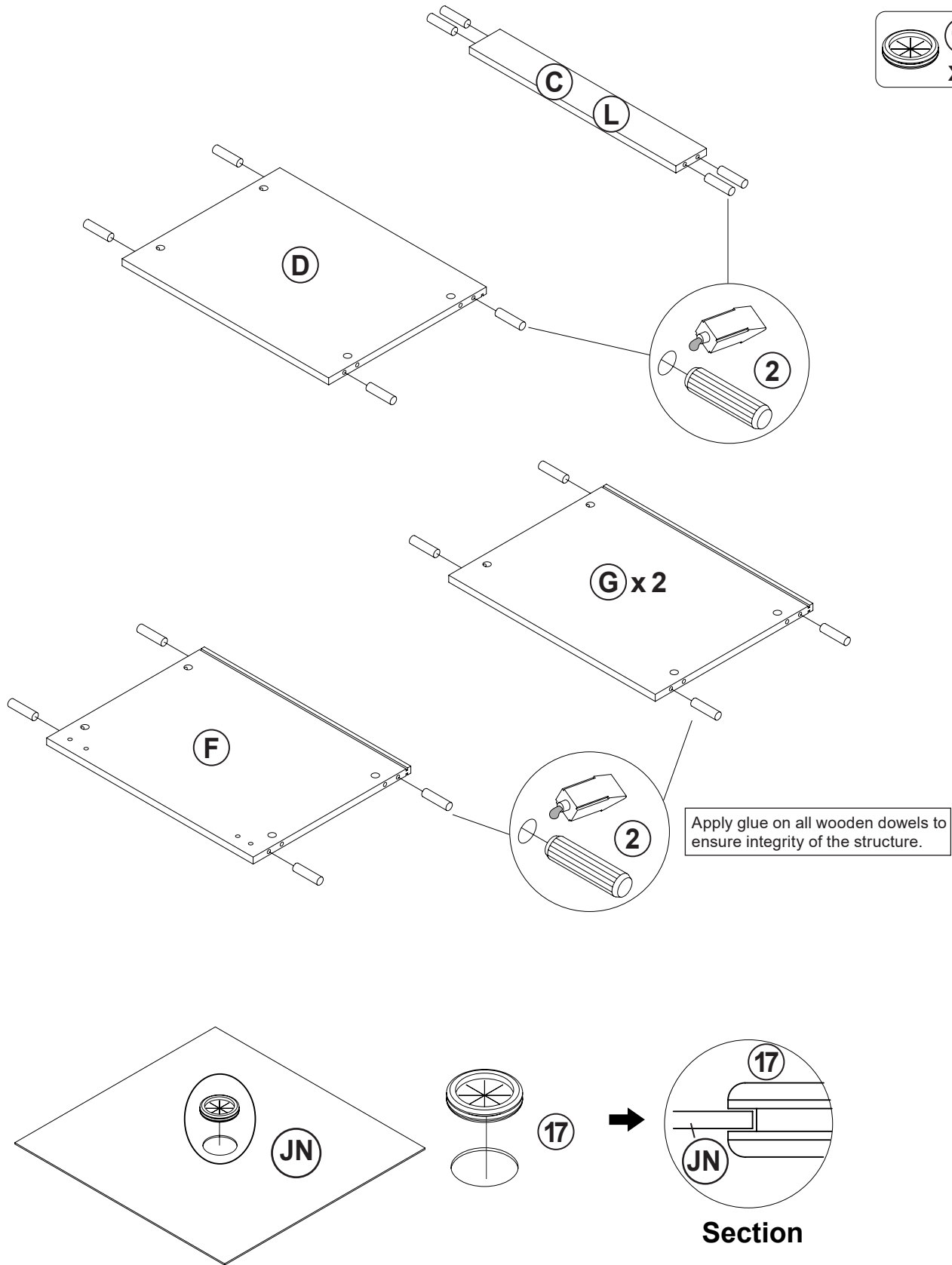
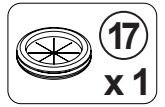
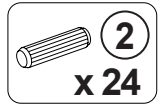

ITEM: 707726

COASTER
FINE FURNITURE

STEP 3

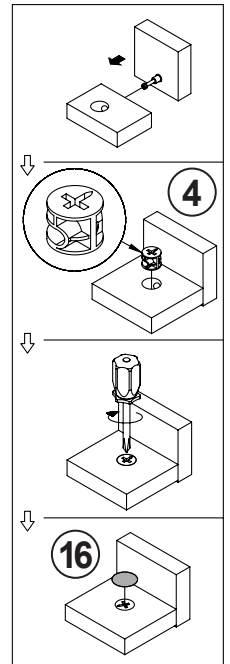
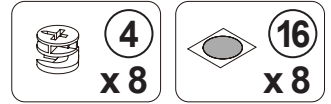
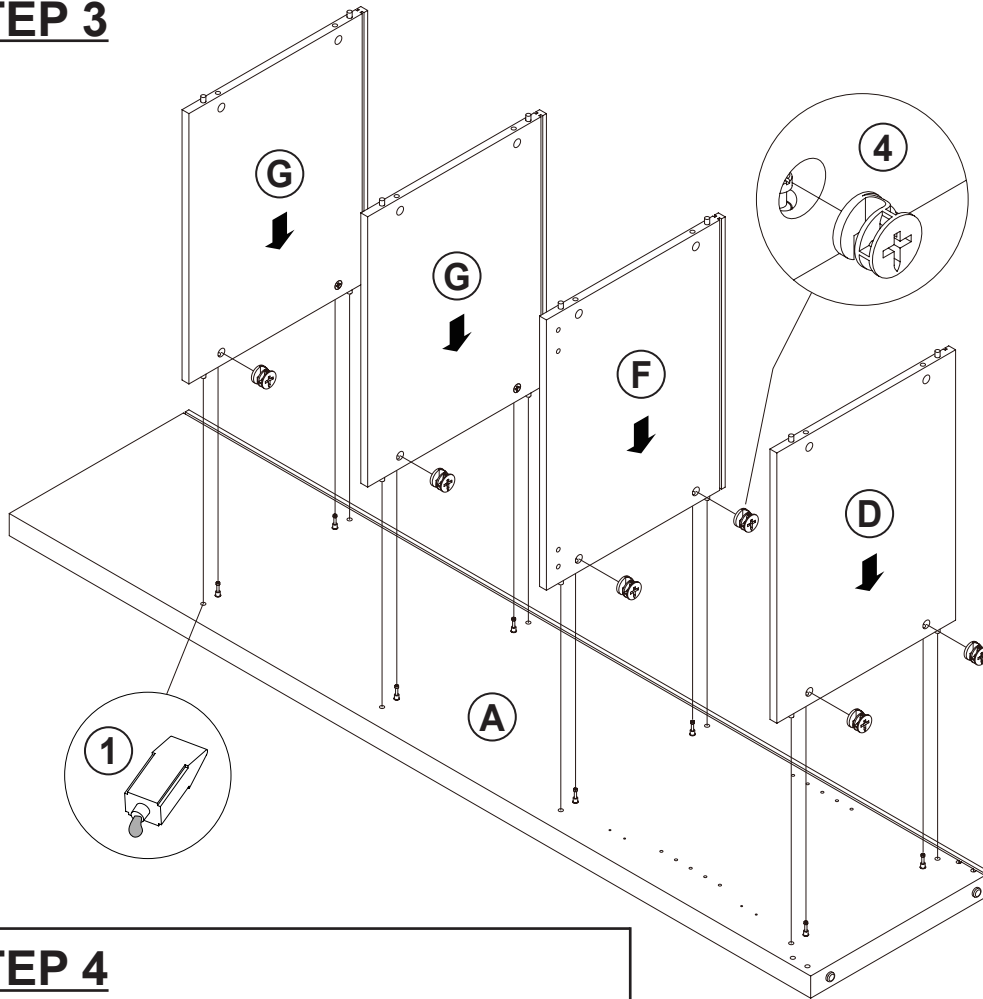

STEP 4

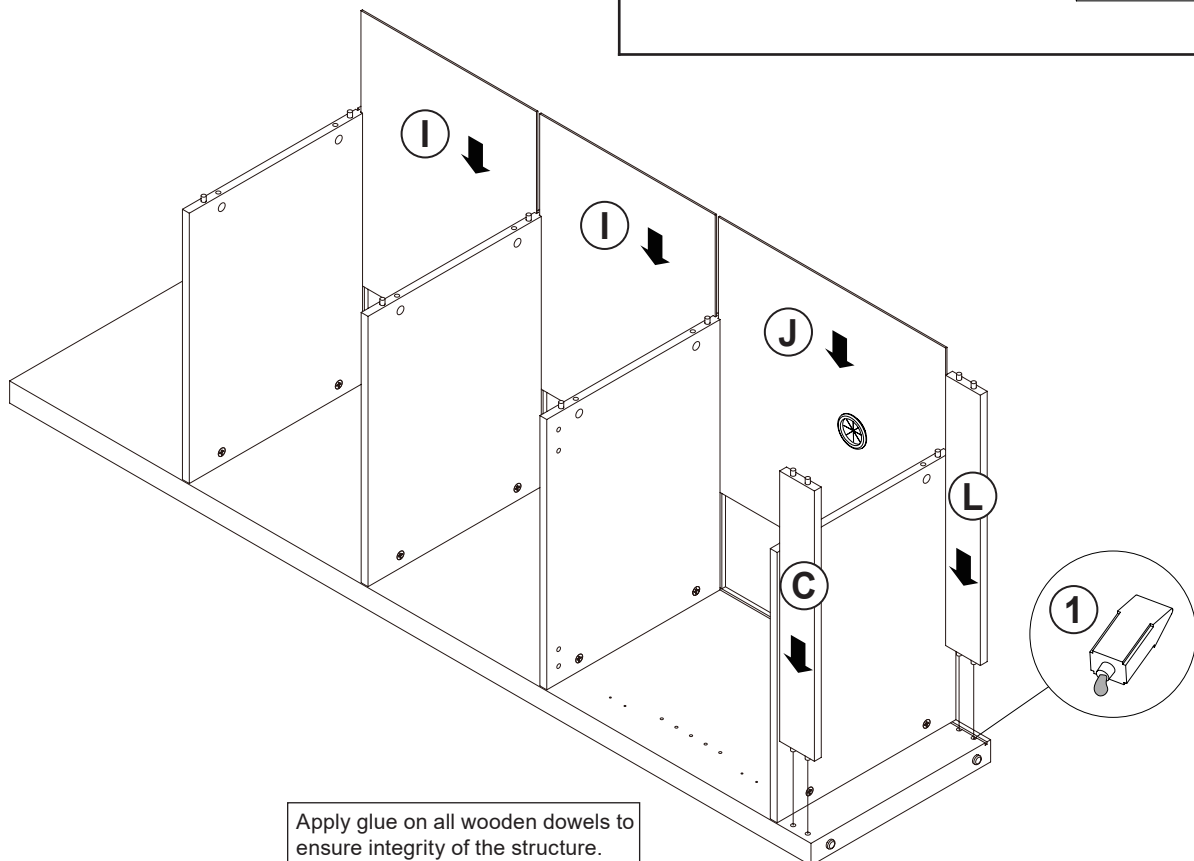

Apply glue on all wooden dowels to ensure integrity of the structure.

ITEM: 707726

COASTER
FINE FURNITURE

STEP 5

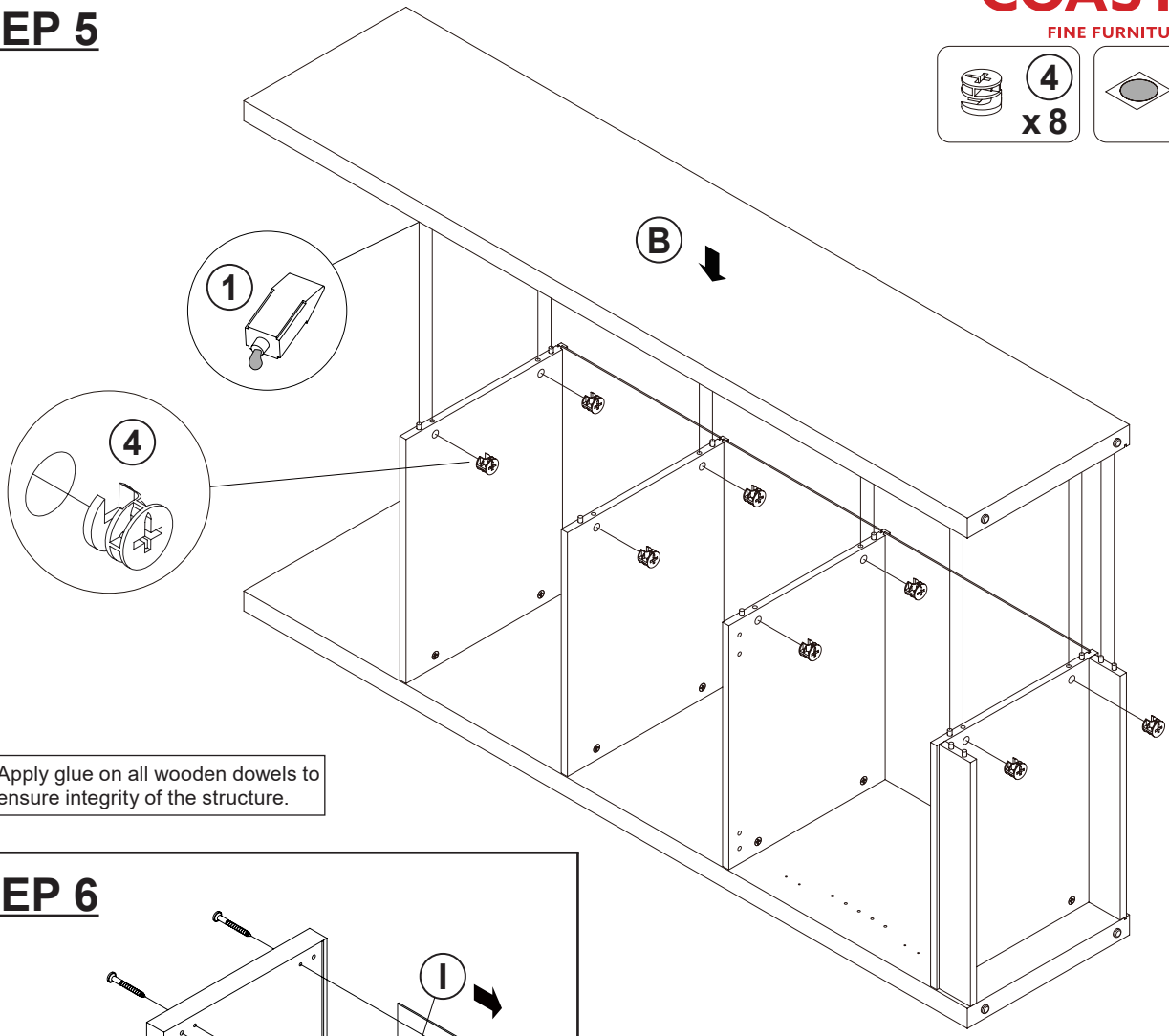
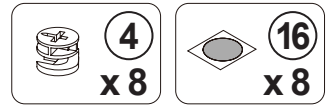

Apply glue on all wooden dowels to ensure integrity of the structure.

STEP 6

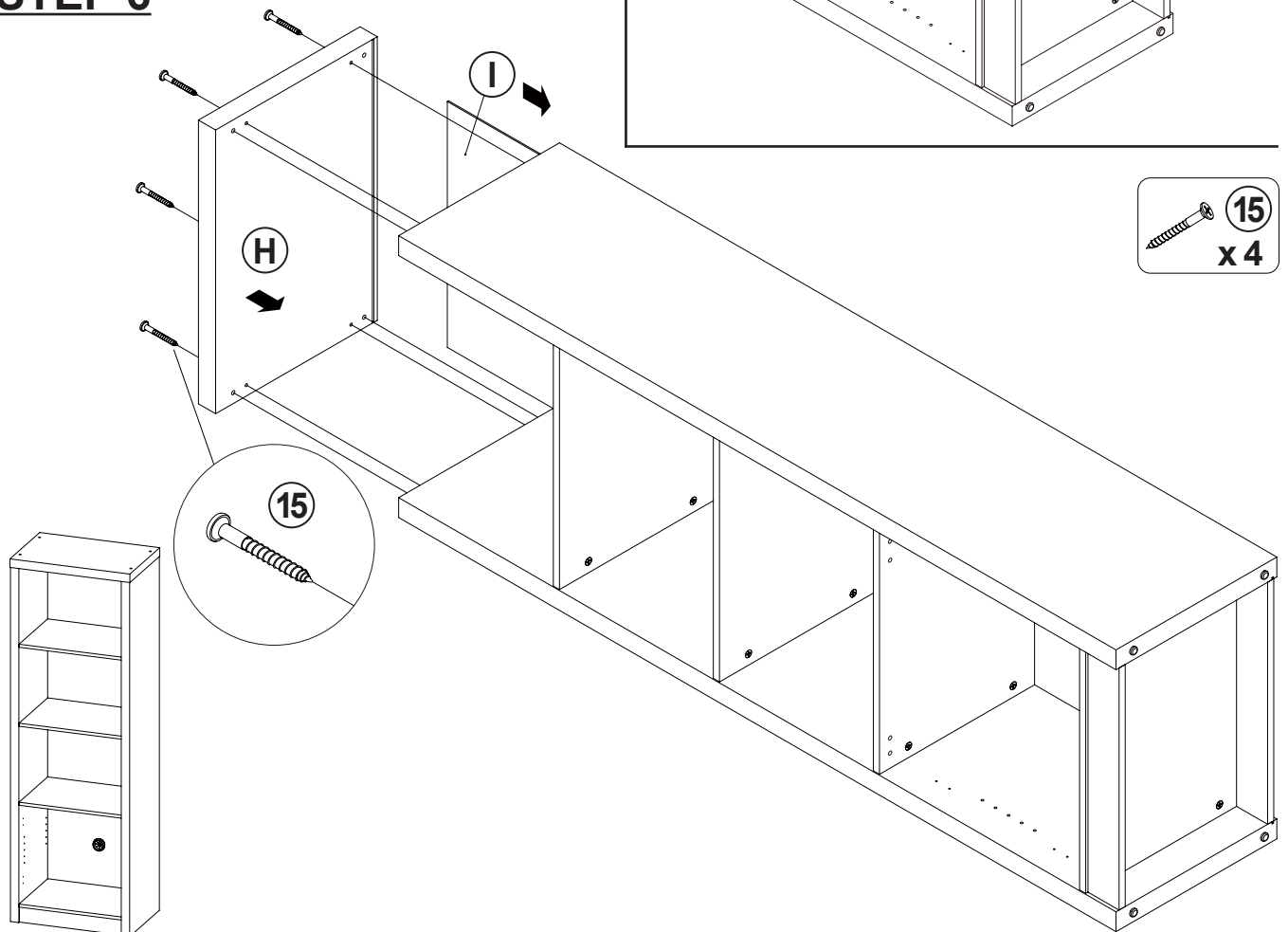
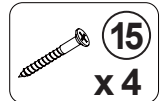

ITEM: 707726

COASTER
FINE FURNITURE

STEP 7

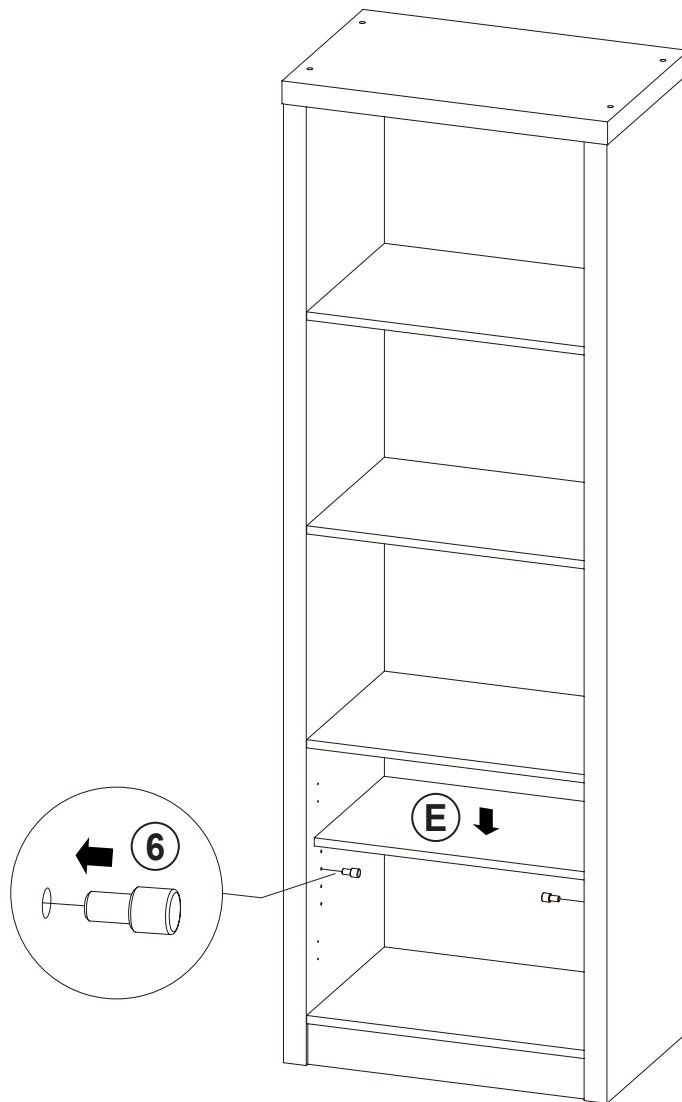
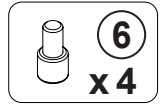

STEP 8

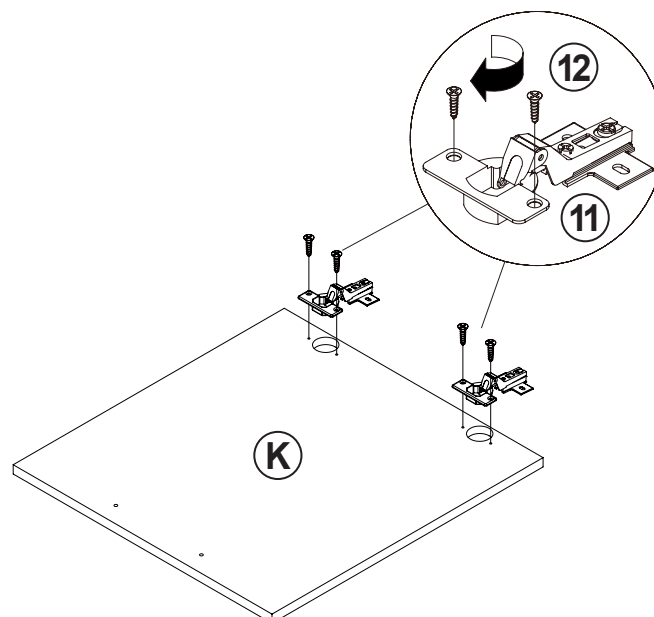
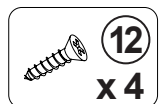
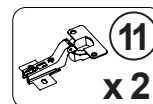

ITEM: 707726

COASTER[®]

FINE FURNITURE

STEP 9

LEFT

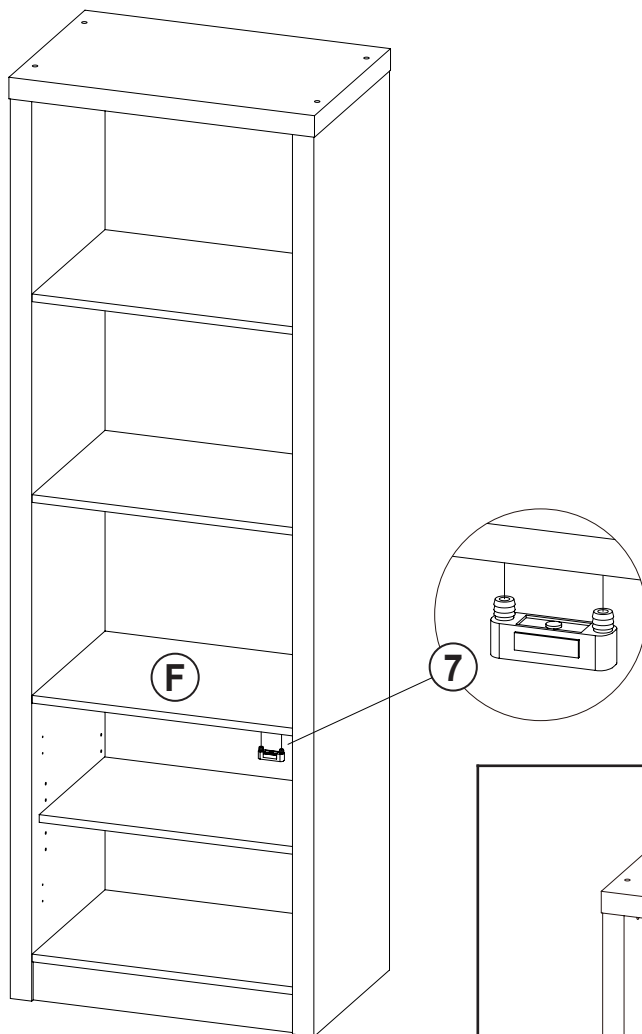
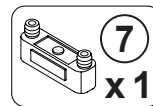

RIGHT

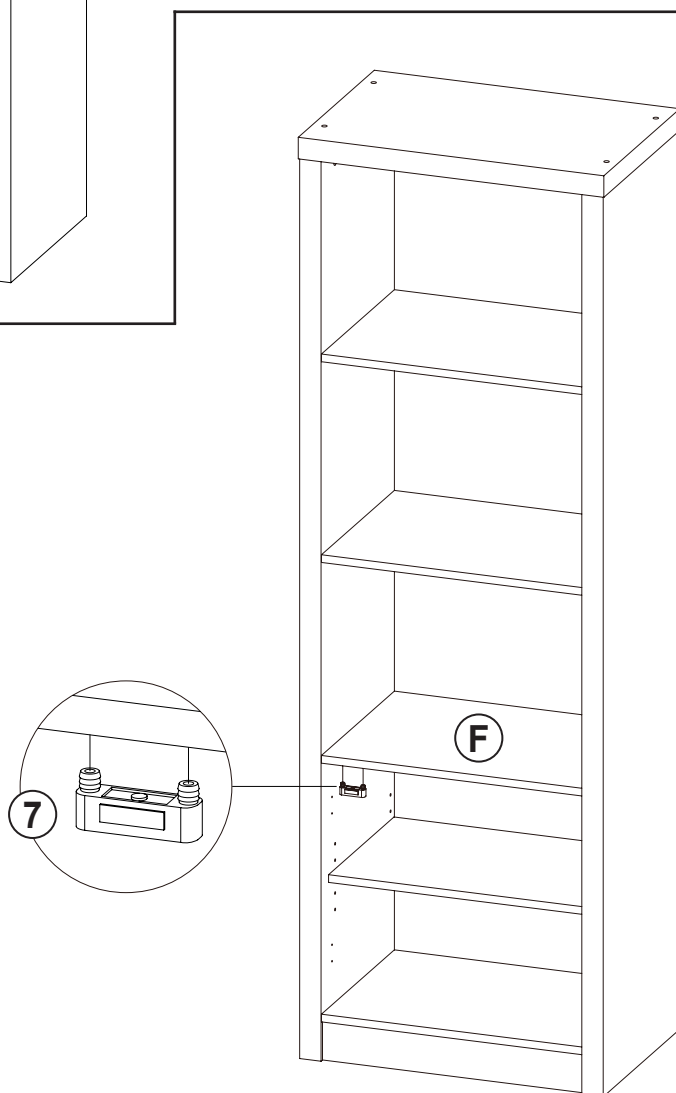

ITEM: 707726

COASTER
FINE FURNITURE

STEP 10

- 8 x 1
- 9 x 2
- 10 x 2
- 12 x 4

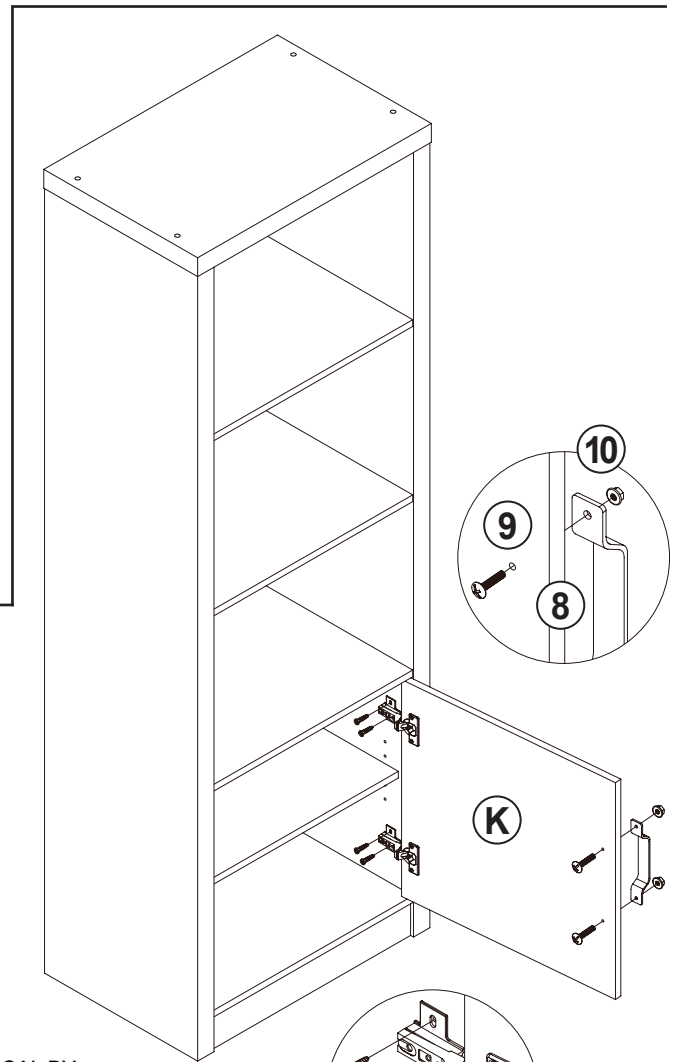
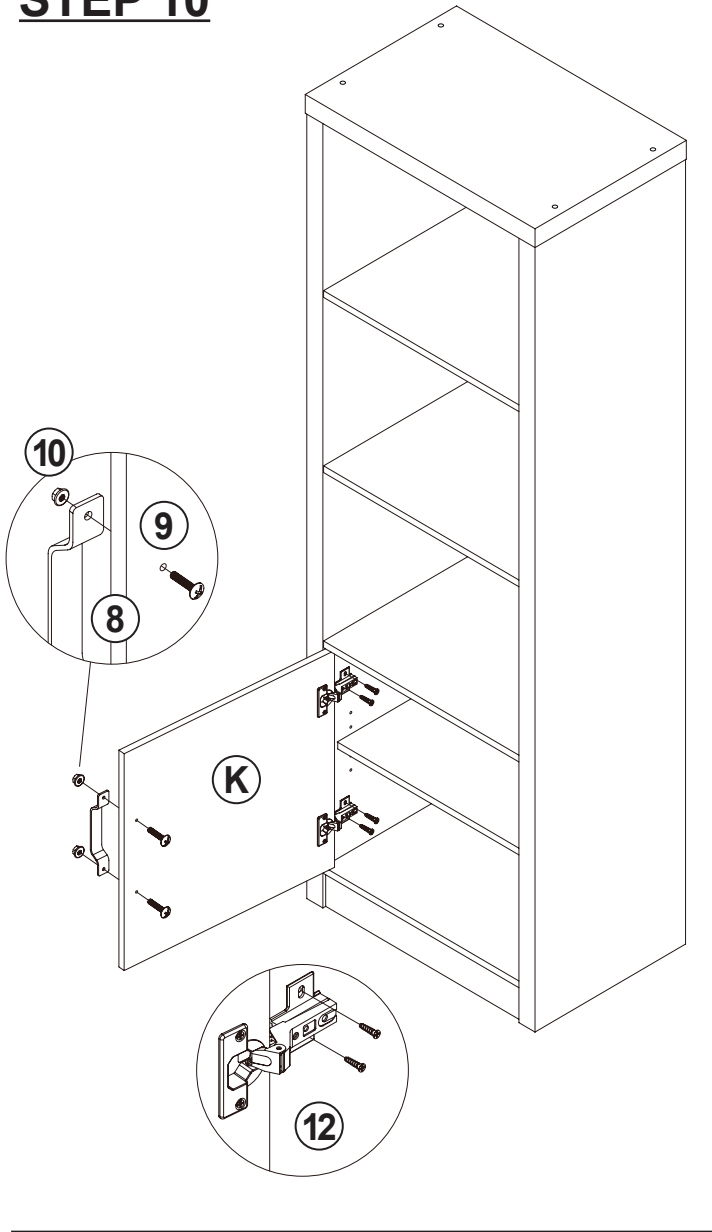

RIGHT

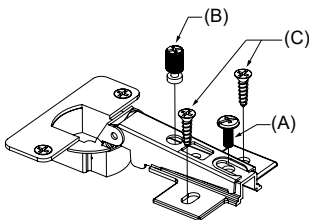

HORIZONTAL BY SCREW A ADJUSTMENT

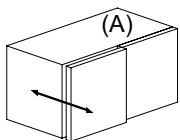

LATERAL BY SCREW B ADJUSTMENT

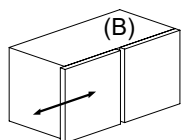

VERTICAL BY SCREW C ADJUSTMENT

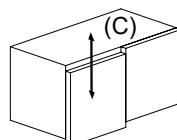

ITEM: 707726

COASTER
FINE FURNITURE

STEP 11

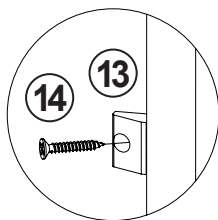
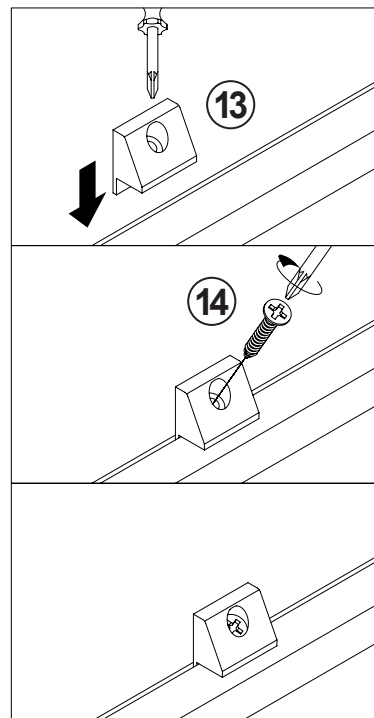
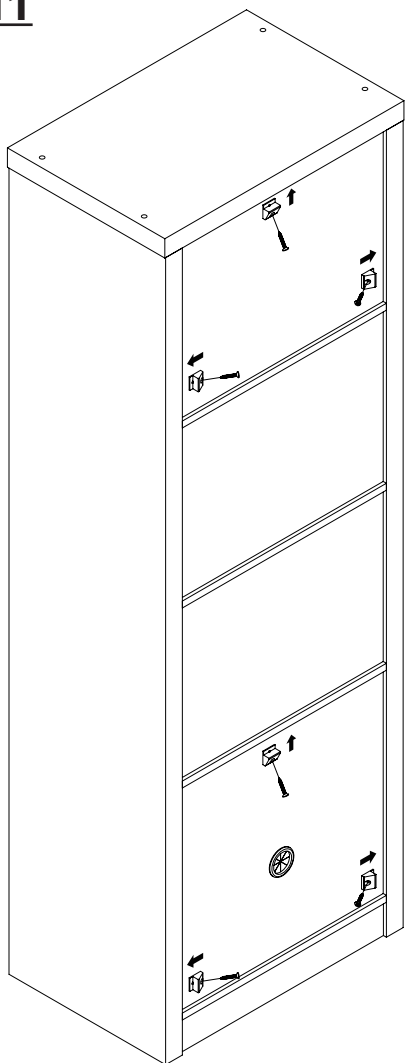
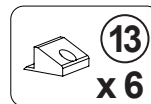

STEP 12

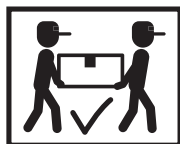
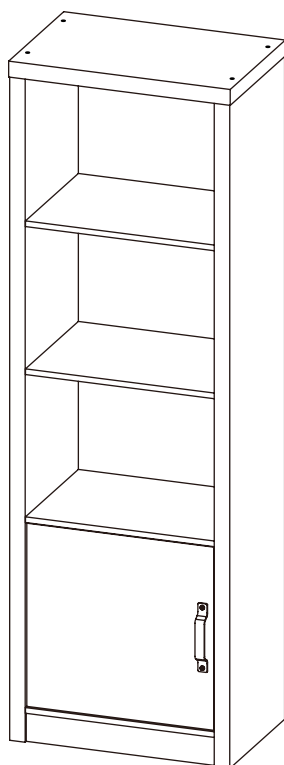

ITEM: 707726

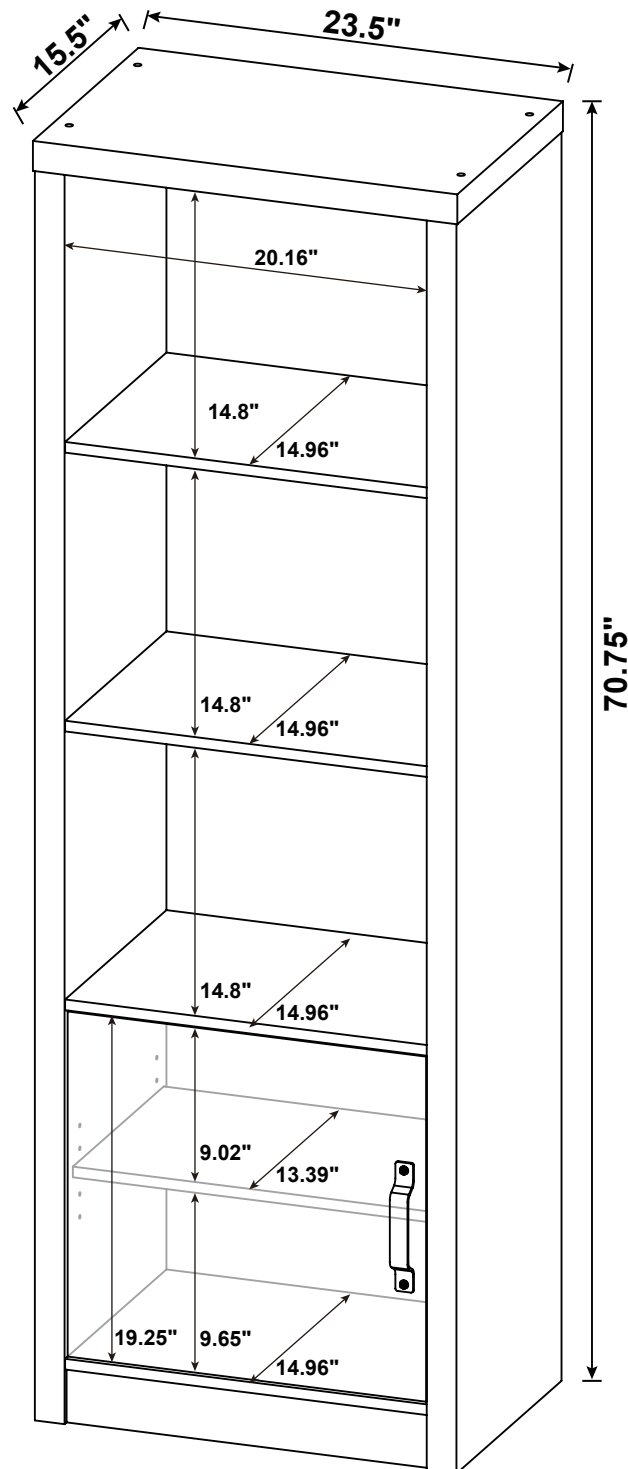

Note : Dimension tolerance $\pm 5\%$

ANTI-TIPPING INSTALLMENT INSTRUCTIONS FURNITURE TIPPING RESTRAINT

WARNING

Injury may result from tipping furniture.
This restraint may protect against tipping furniture.
Do not allow children to climb on furniture.
This restraint is not a substitute for proper adult supervision.
Failure to detach this restraint before moving the furniture may result in injury and damage.

This restraint must be screwed to a wood stud on the wall, using the long screw provided.

STEP 1

Secure the bracket to the back top of the unit, using the short screw provided, as shown in the drawing.

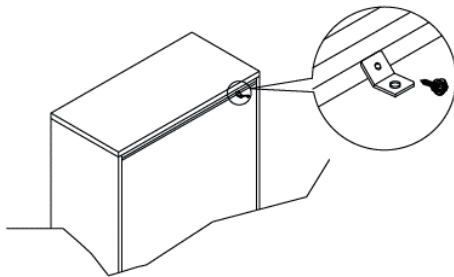

STEP 2

Locate the wood stud on the wall, and secure the other bracket, 2 inches below the back of the unit.

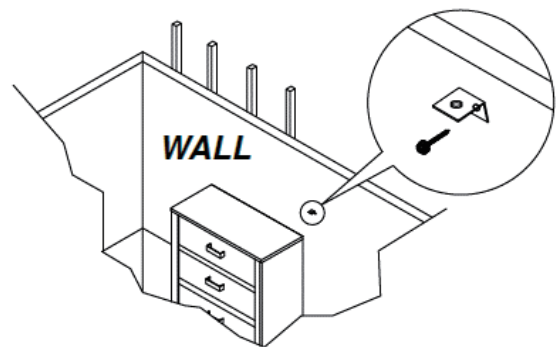

STEP 3

Place the furniture into position so both mounting brackets are vertically in line. Lace the end of the restraint strap through the larger hole in each mounting bracket. Bring both ends together and slide the flat end through the locking end, and drag it through, until the slack is removed. Ensure that the strap is securely laced and locked.

