

ASSEMBLY INSTRUCTIONS
COASTER FINE FURNITURE



Fine Furniture for every stage of life

150628(B1 & B2)
5Pc Counter Height Dining Set

ITEM: 150628(B1 & B2)



ASSEMBLY INSTRUCTIONS

ASSEMBLY TIPS:

1. Remove hardware from box and sort by size.
2. Please check to see that all hardware and parts are present prior to start of assembly.
3. Please follow attached instructions in the same sequence as numbered to assure fast & easy assembly.



WARNING!

1. Don't attempt to repair or modify parts that are broken or defective. Please contact the store immediately.
2. This product is for home use only and not intended for commercial establishments.





ASSEMBLY TIME







40 MINUTES

PARTS IDENTIFICATION

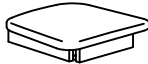
B1 (BOX 1)

A	TABLE TOP		1PC
B	TABLE LEG		4PCS

B2 (BOX 2)

C	BACK FRAME		4PCS
D	SEAT CUSHION WITH FRAME		4PCS
E	LEFT FRONT LEG		4PCS
F	RIGHT FRONT LEG		4PCS
G	FRONT STRETCHER		4PCS
H	LEFT SIDE STRETCHER (1HOLE MARKING)		4PCS
I	RIGHT SIDE STRETCHER (2HOLE MARKING)		4PCS

ITEM: 150628(B1 & B2)



ASSEMBLY INSTRUCTIONS

ASSEMBLY TIPS:

1. Remove hardware from box and sort by size.
2. Please check to see that all hardware and parts are present prior to start of assembly.
3. Please follow attached instructions in the same sequence as numbered to assure fast & easy assembly.







WARNING!







1. Don't attempt to repair or modify parts that are broken or defective. Please contact the store immediately.
2. This product is for home use only and not intended for commercial establishments.

HARDWARE IDENTIFICATION

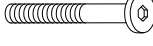
Z-B1 (BOX 1) - HARDWARE PACK IS LOCATED IN 150628 (B1)

1	HEX NUT (M8 - RBW)		8PCS
2	LOCK WASHER (M8 x 13MM - RBW)		8PCS
3	FLAT WASHER (M8 x 13MM - RBW)		8PCS
4	WRENCH		1PC

Z-B2 (BOX 2) - HARDWARE PACK IS LOCATED IN 150628 (B2)

5	LONG BOLT (M6 X 70MM - RBW)		16PCS
6	MEDIUM BOLT (M6 X 60MM - RBW)		16PCS
7	SHORT BOLT (M6 X 35MM - RBW)		8PCS
8	LOCK WASHER (M6 X 13MM - RBW)		40PCS
9	FLAT WASHER (1/4" X 19MM - RBW)		40PCS
10	FLAT HEAD SCREW (M4 X 32MM - RBW)		24PCS
11	ALLEN WRENCH (M4 X 65MM - BLK)		1PC

NOTE:

Phillips head screw driver is required in the assembly process; however, manufacturer does not provide this item.

ITEM: 150628(B1&B2)

ASSEMBLY INSTRUCTIONS

STEP 1

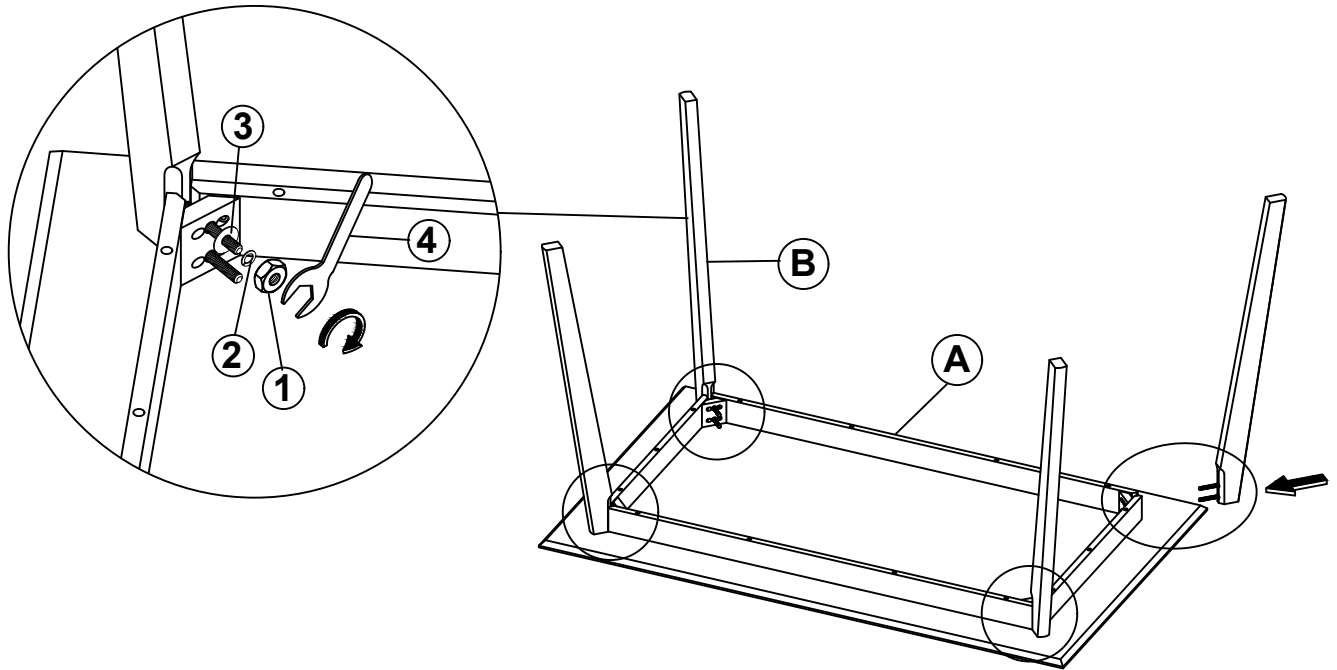

STEP 2

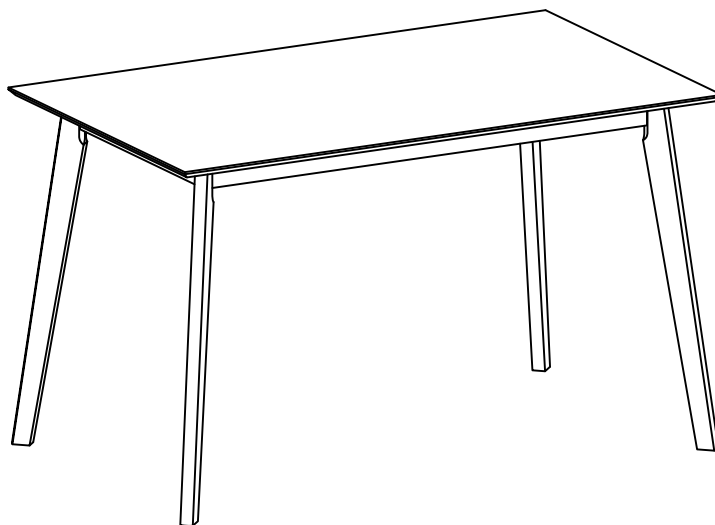

ITEM: 150628(B1&B2)

ASSEMBLY INSTRUCTIONS

STEP 3

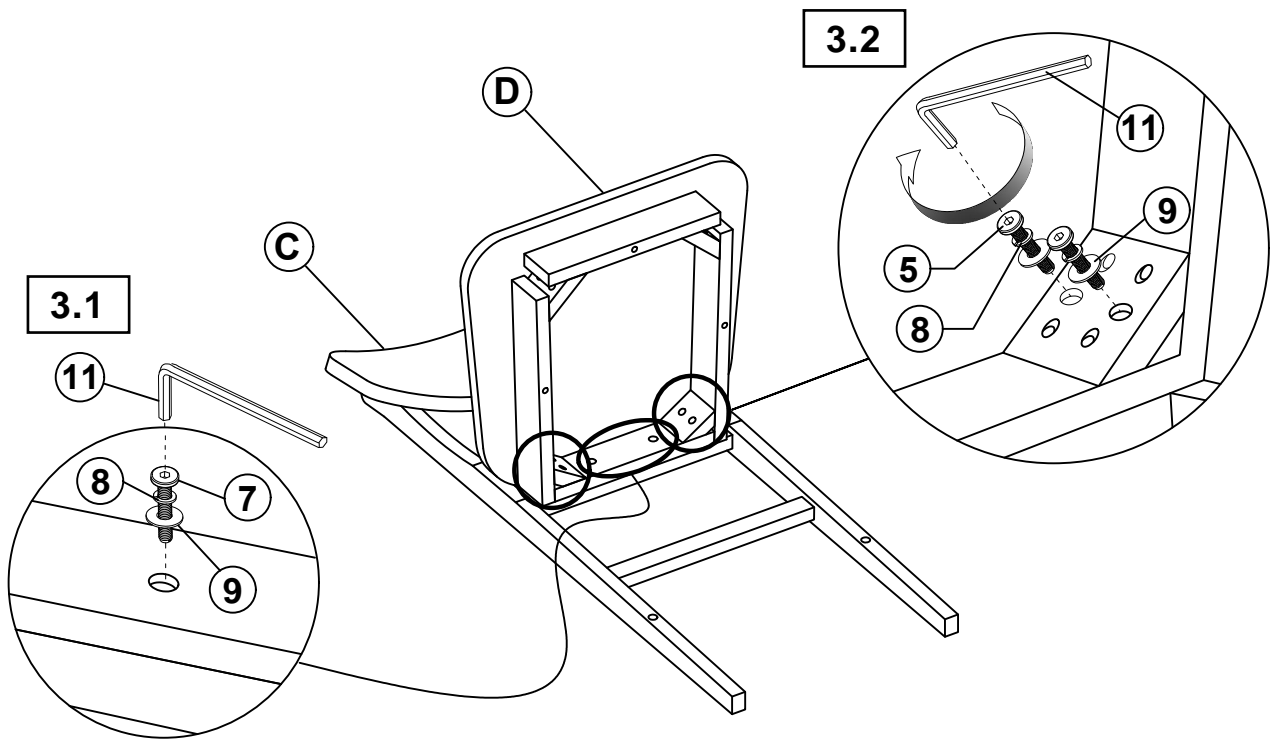

STEP 4

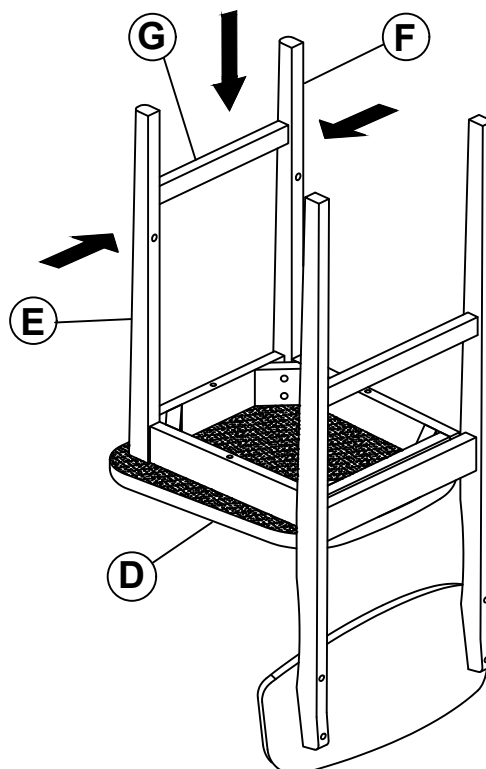

ITEM: 150628(B1&B2)



ASSEMBLY INSTRUCTIONS

STEP 5

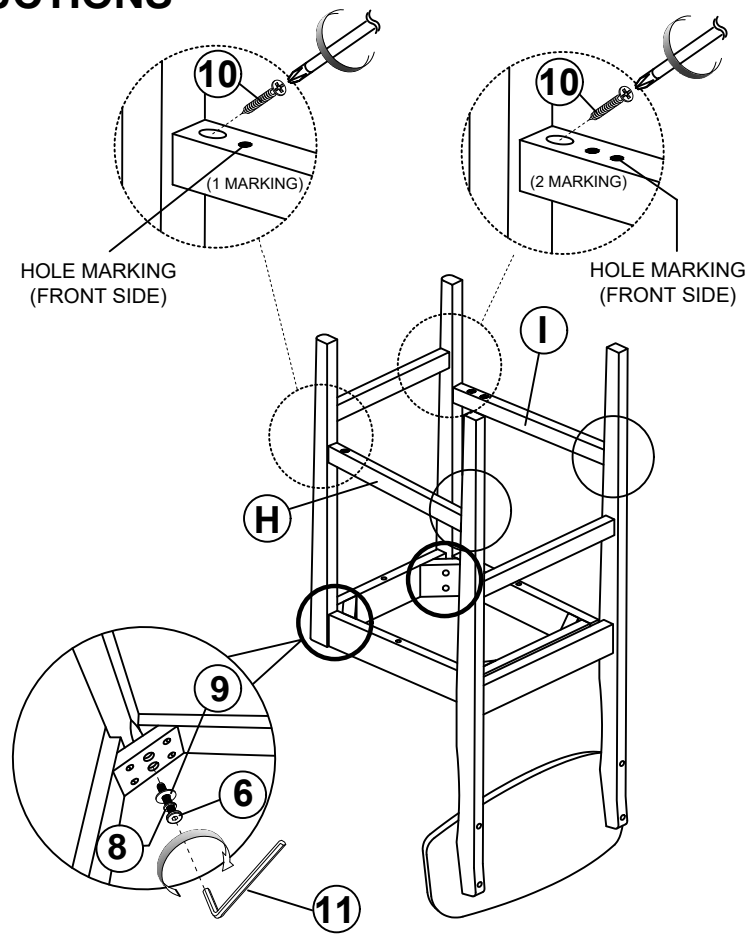

STEP 6 COMPLETE

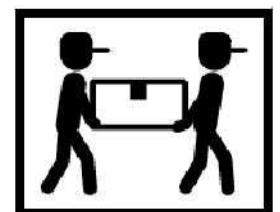
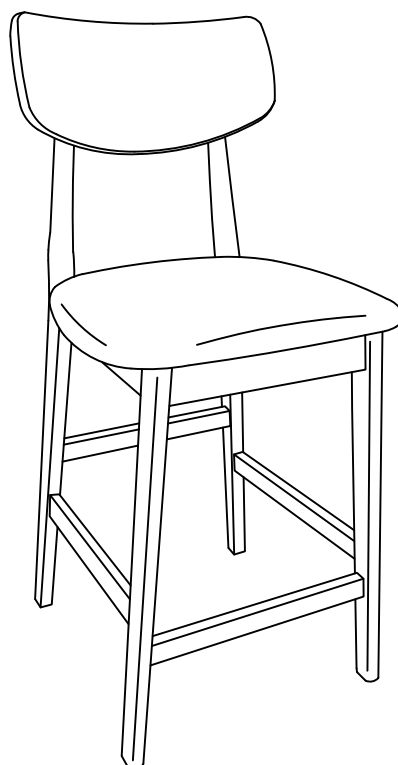

ITEM: 150628(B1&B2)

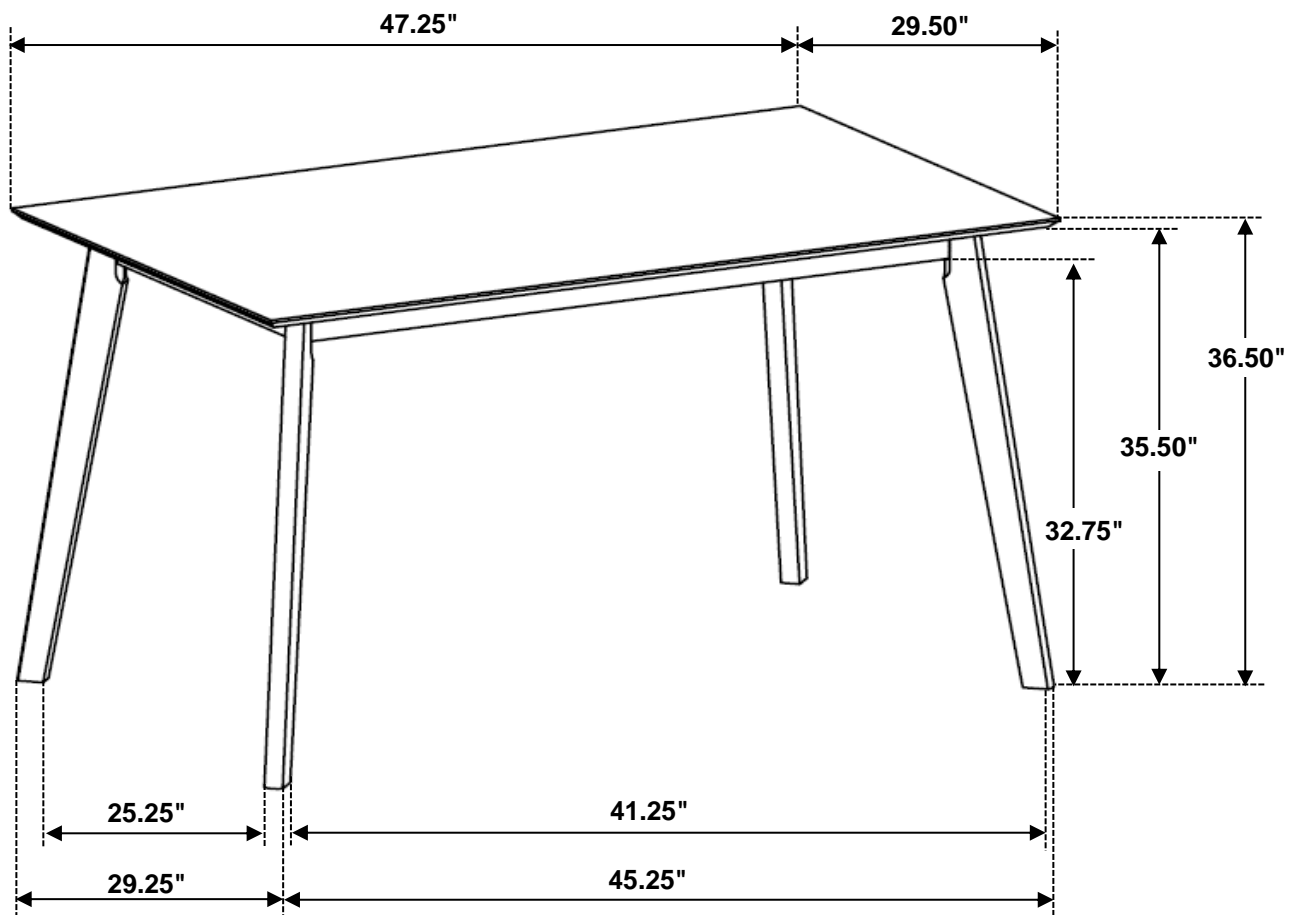

Note: Dimension tolerance $\pm 5\%$

ITEM: 150628(B1&B2)

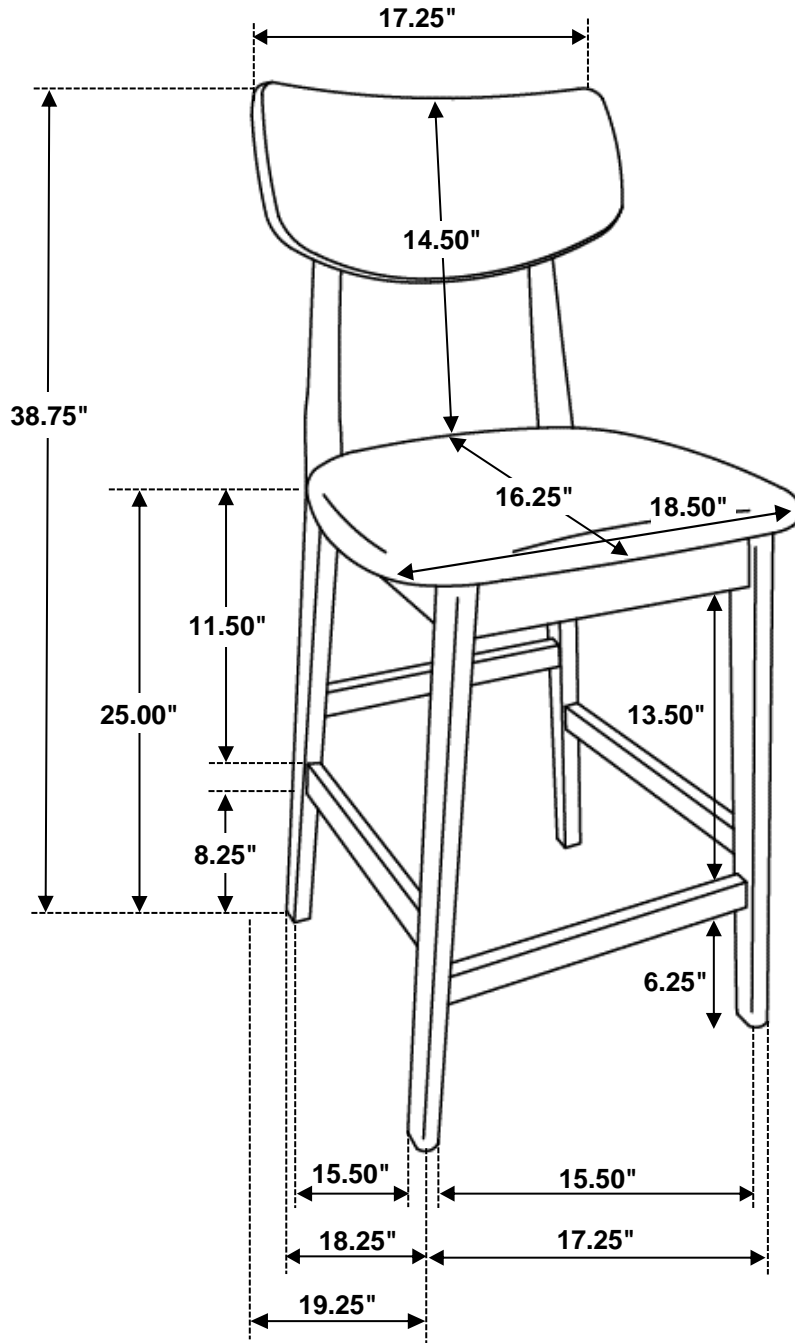

Note: Dimension tolerance $\pm 5\%$