

ASSEMBLY INSTRUCTIONS
COASTER FINE FURNITURE

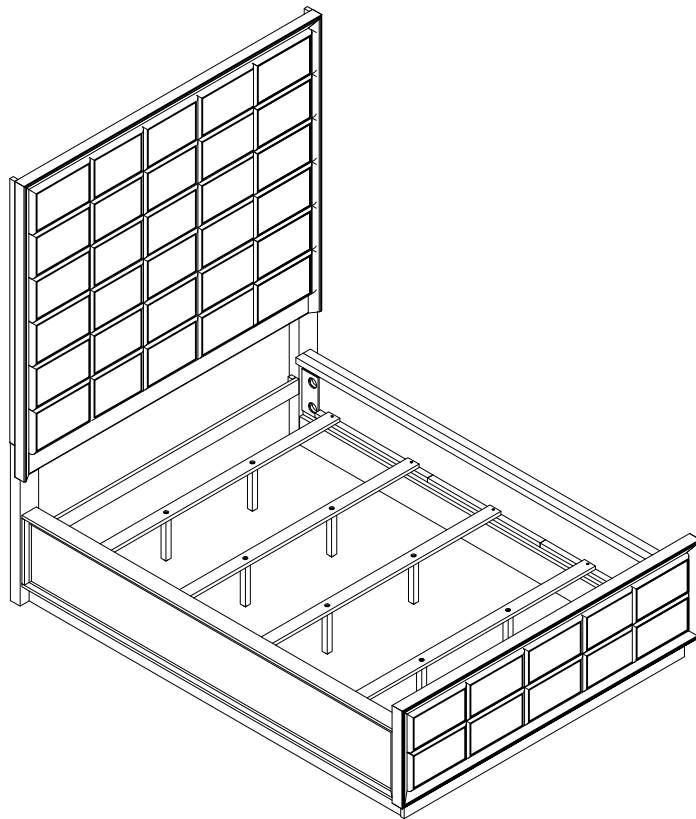

Fine Furniture for every stage of life

223261KW (B1-B3)
California King Bed

ITEM: 223261KW (B1-B3)



ASSEMBLY INSTRUCTIONS

ASSEMBLY TIPS:

1. Remove hardware from box and sort by size.
2. Please check to see that all hardware and parts are present prior to start of assembly.
3. Please follow attached instructions in the same sequence as numbered to assure fast & easy assembly.

WARNING!



1. Don't attempt to repair or modify parts that are broken or defective. Please contact the store immediately.
2. This product is for home use only and not intended for commercial establishments.

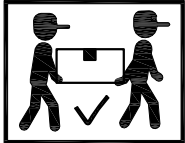

ASSEMBLY TIME

20 MINUTES

PARTS IDENTIFICATION

B1 (BOX 1)

A HEADBOARD PANEL

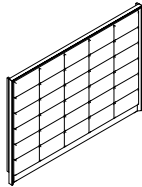

1PC

B LEFT HEADBOARD LEG



1PC

C RIGHT HEADBOARD LEG



1PC

D HEADBOARD BOTTOM RAIL

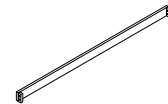

1PC

B2 (BOX 2)

E FOOTBOARD

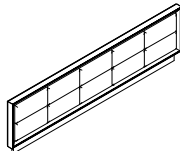

1PC

B3 (BOX 3)

F BED RAIL

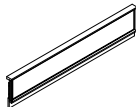

2PCS

HB 223261KW (B1) FROM BOX 1 HEADBOARD COMPLETE

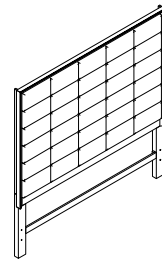

1PC

G BED SLAT



4PCS

E 223261KW (B2) FROM BOX 2 FOOTBOARD

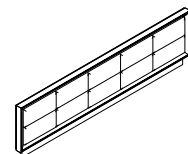

1PC

H BED SLAT SUPPORT WITH LEVELER



8PCS

ITEM: 223261KW (B1-B3)



ASSEMBLY INSTRUCTIONS

ASSEMBLY TIPS:

1. Remove hardware from box and sort by size.
2. Please check to see that all hardware and parts are present prior to start of assembly.
3. Please follow attached instructions in the same sequence as numbered to assure fast & easy assembly.







WARNING!



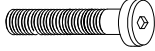

1. Don't attempt to repair or modify parts that are broken or defective. Please contact the store immediately.
2. This product is for home use only and not intended for commercial establishments.

HARDWARE IDENTIFICATION

Z - B1 (BOX 1)-HARDWARE PACK IS LOCATED IN 223261KW (B1)

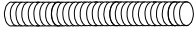
1	LONG BOLT (5/16" x 45mm - BLK)		10PCS	4	FLAT WASHER (5/16" x 19 x 1.5mm - BLK)		14PCS
2	SHORT BOLT (5/16" x 38mm - BLK)		4PCS	5	ALLEN WRENCH (74 x 30 x 4mm - BLK)		1PC
3	LOCK WASHER (5/16" - BLK)		14PCS				

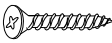
Z - B3 (BOX 3)- HARDWARE PACK IS LOCATED IN 223261KW (B3)

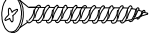
6	THREADED BOLT (5/16" x 75mm - BLK)		8PCS	11	L-BRACKET (15 x 15 x 1mm - BLK)		4 PCS
7	U-SQUARE WASHER (25 x 15 x 2mm - BLK)		8PCS	12	SHORT FLAT HEAD SCREW (3.5 x 15mm - BLK)		8PCS
8	HEX NUT (5/16" x 17mm - BLK)		8PCS				
9	WRENCH (13MM - BLK)		1PC				
10	LONG FLAT HEAD SCREW (4 x 32mm - BLK)		8PCS				

NOTE:

Phillips head screw driver is required in the assembly process; however, manufacturer does not provide this item.

ITEM: 223261KW (B1-B3)

ASSEMBLY INSTRUCTIONS



STEP 1

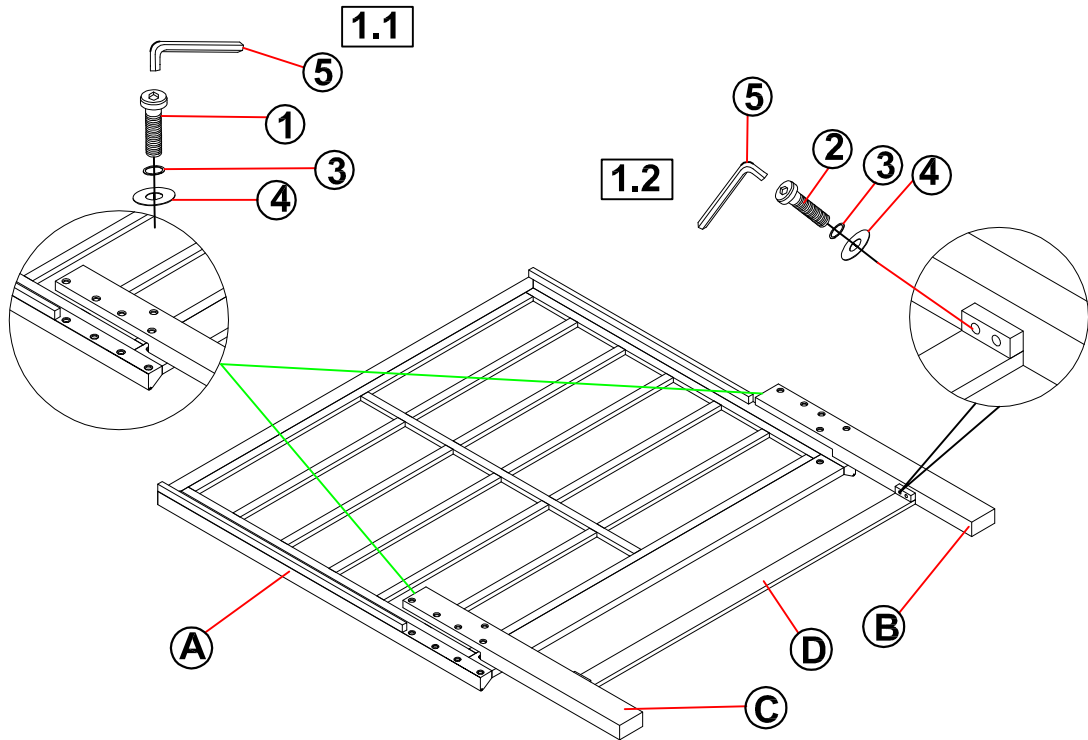

STEP 2

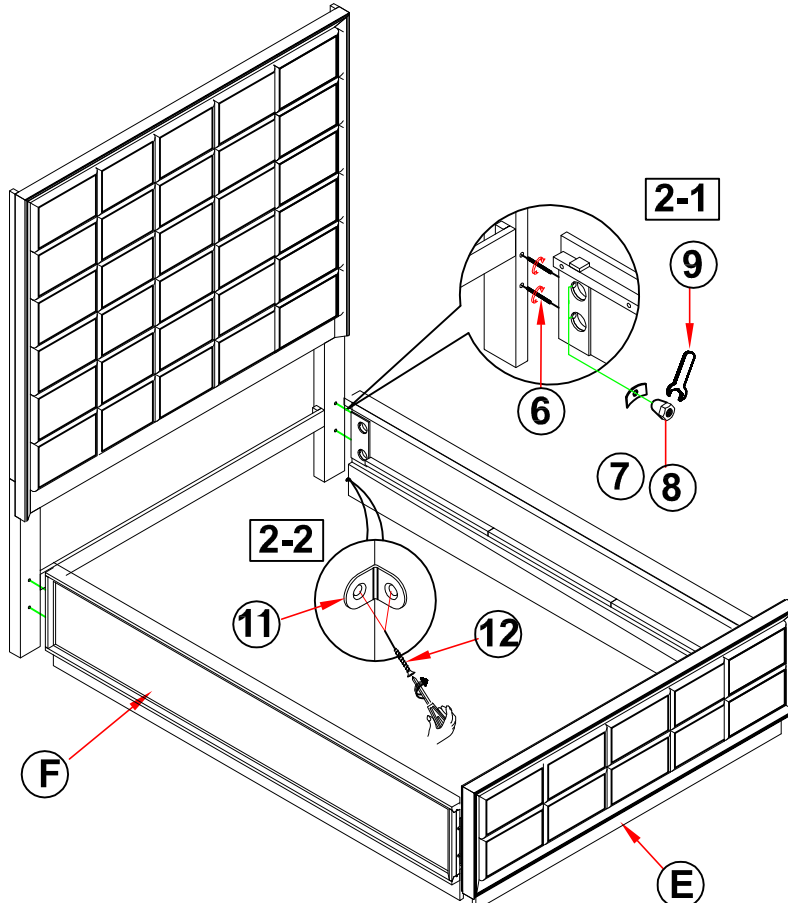

ITEM: 223261KW (B1-B3)

ASSEMBLY INSTRUCTIONS



STEP 3

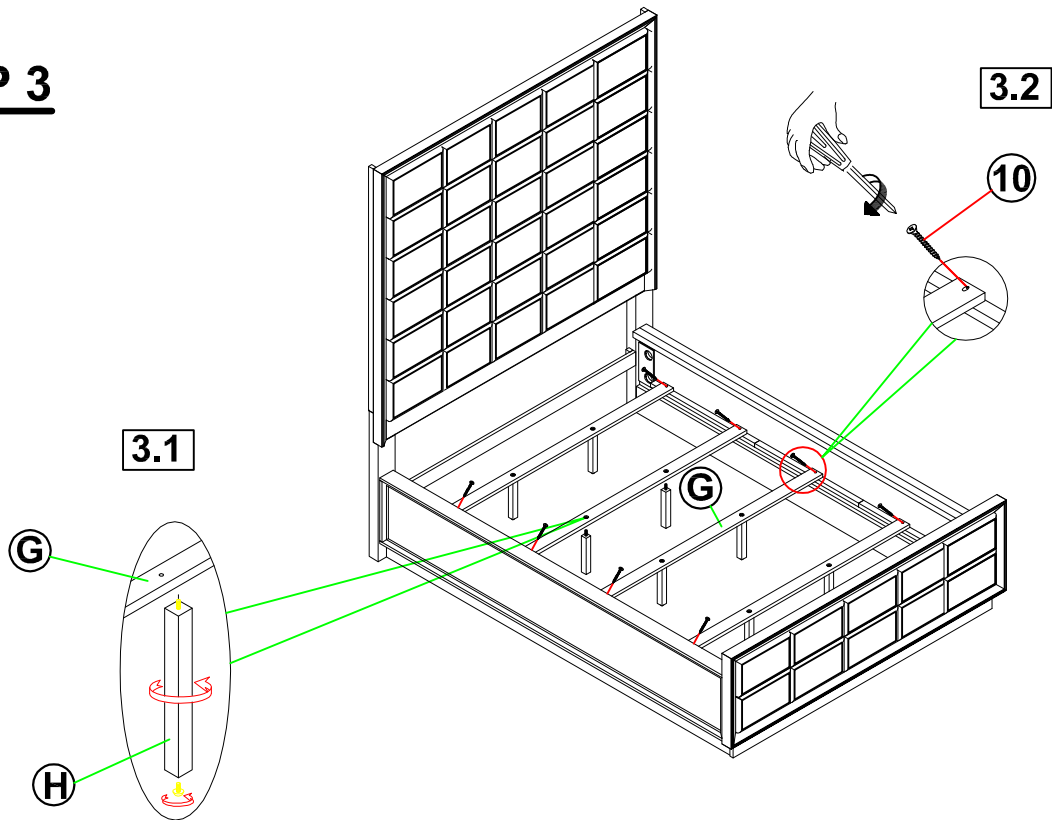

STEP 4

COMPLETE

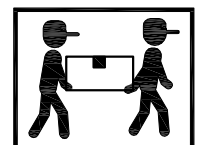
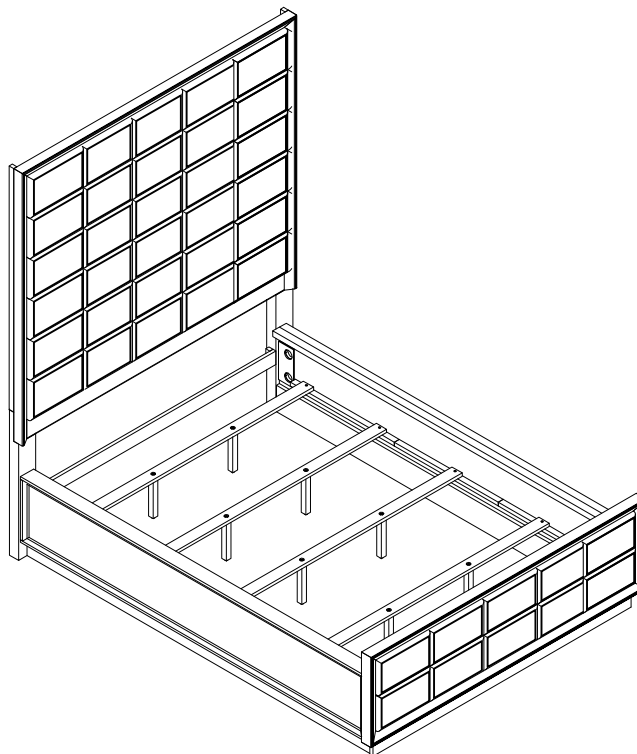

ITEM: **223261KW (B1-B3)**



Inner Size: 77.00"W X 85.50"D

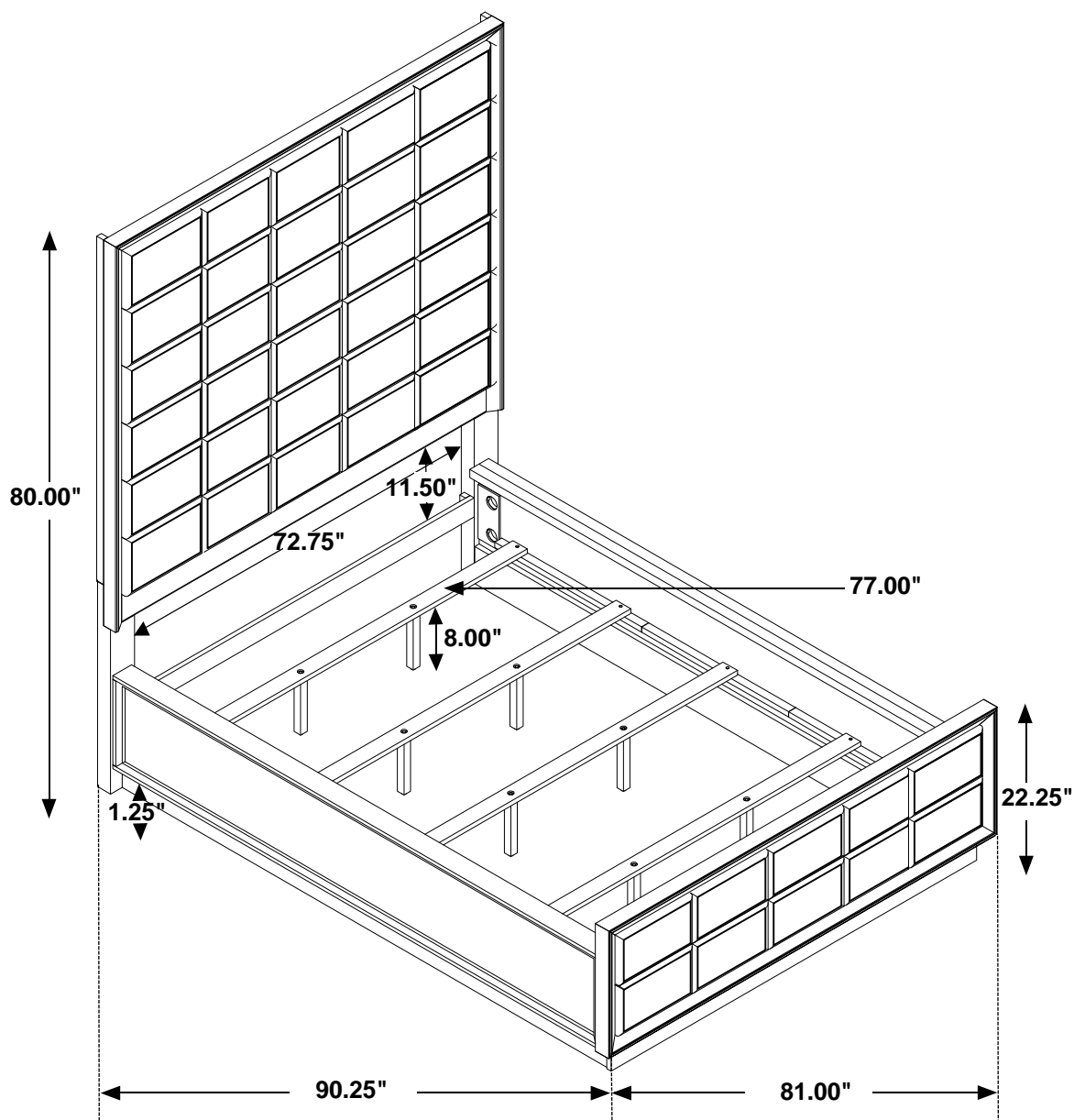

Note: Dimension tolerance $\pm 5\%$