

ASSEMBLY INSTRUCTIONS
COASTER FINE FURNITURE

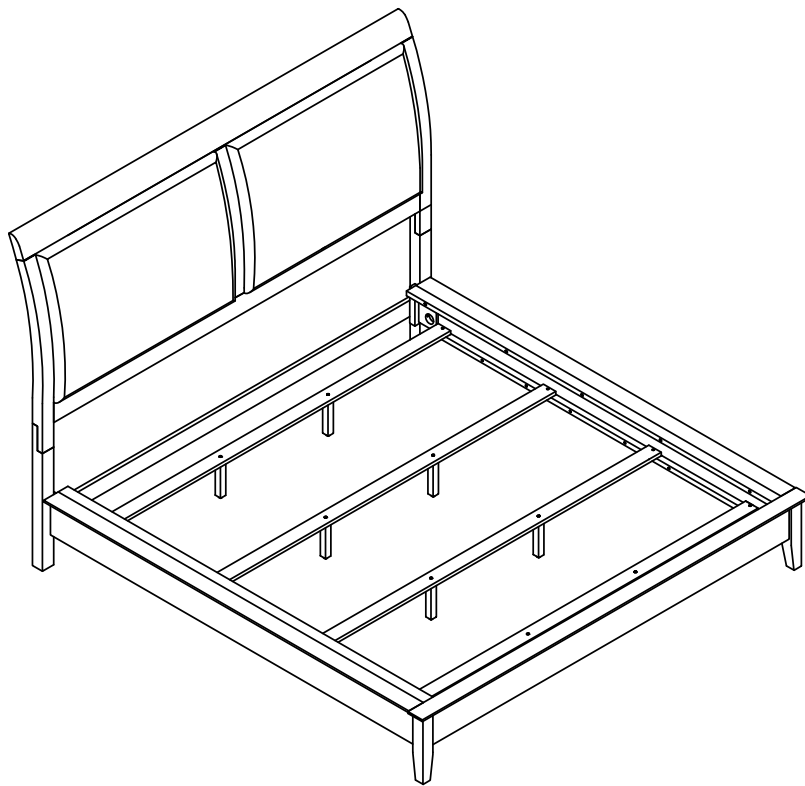

Fine Furniture for every stage of life

223471KW (B1-B3)
California King Bed

ITEM: 223471KW(B1-B3)



ASSEMBLY INSTRUCTIONS

ASSEMBLY TIPS:

1. Remove hardware from box and sort by size.
2. Please check to see that all hardware and parts are present prior to start of assembly.
3. Please follow attached instructions in the same sequence as numbered to assure fast & easy assembly.



WARNING!

1. Don't attempt to repair or modify parts that are broken or defective. Please contact the store immediately.
2. This product is for home use only and not intended for commercial establishments.



ASSEMBLY TIME

30 MINUTES

PARTS IDENTIFICATION

B1 (BOX 1)

A HEADBOARD PANEL

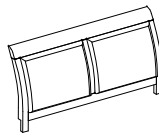

1PC

B RIGHT HEADBOARD LEG



1PC

C LEFT HEADBOARD LEG



1PC

D HEADBOARD BOTTOM RAIL



1PC

B2 (BOX 2)

E FOOTBOARD



1PC

B3 (BOX 3)

F BED RAIL



2PCS

G BED SLAT



4PCS

H BED SLAT SUPPORT WITH LEVELER



8PCS

I RAIL TOP



2PCS

HB 223471KW(B1)
FROM BOX 1
HEADBOARD
COMPLETE

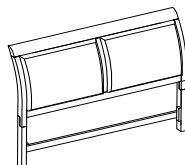

1PC

FB 223471KW(B2)
FROM BOX 2
FOOTBOARD

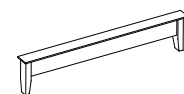

1PC

NOTE:

Phillips head screw driver is required in the assembly process; however, manufacturer does not provide this item.

ITEM: 223471KW(B1-B3)



ASSEMBLY INSTRUCTIONS

ASSEMBLY TIPS:

1. Remove hardware from box and sort by size.
2. Please check to see that all hardware and parts are present prior to start of assembly.
3. Please follow attached instructions in the same sequence as numbered to assure fast & easy assembly.





WARNING!







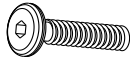



1. Don't attempt to repair or modify parts that are broken or defective. Please contact the store immediately.
2. This product is for home use only and not intended for commercial establishments.

HARDWARE IDENTIFICATION

Z-B1 (BOX 1) - HARDWARE PACK IS LOCATED IN 223471KW(B1)

1	LONG BOLT (\emptyset 5/16" x 45MM- RBW)		8PCS	4	FLAT WASHER (\emptyset 5/16" - RBW)		12PCS
2	SHORT BOLT (\emptyset 5/16" x 35MM- RBW)		4PCS	5	ALLEN WRENCH (4MM - RBW)		1PC
3	LOCK WASHER (\emptyset 5/16" - RBW)		12PCS				

Z-B3 (BOX 3) - HARDWARE PACK IS LOCATED IN 223471KW(B3)

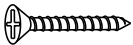
6	THREADED BOLT (\emptyset 5/16" x 90MM - RBW)		8PCS	11	BOLT (\emptyset 1/4" x 45 MM- RBW)		10PCS
7	HALF ROUND NUT (\emptyset 5/16" - RBW)		8PCS	12	LOCK WASHER (\emptyset 1/4" - RBW)		10PCS
8	HEX NUT (\emptyset 5/16" x 14MM - RBW)		8PCS	13	FLAT WASHER (\emptyset 1/4" - RBW)		10PCS
9	WRENCH (14MM - RBW)		1PC	14	ALLEN WRENCH (4MM - RBW)		1PC
10	FLAT HEAD SCREW (\emptyset 4 x 30MM - RBW)		8PCS				

NOTE:

Phillips head screw driver is required in the assembly process; however, manufacturer does not provide this item.

ITEM: 223471KW(B1-B3)

ASSEMBLY INSTRUCTIONS



STEP 1

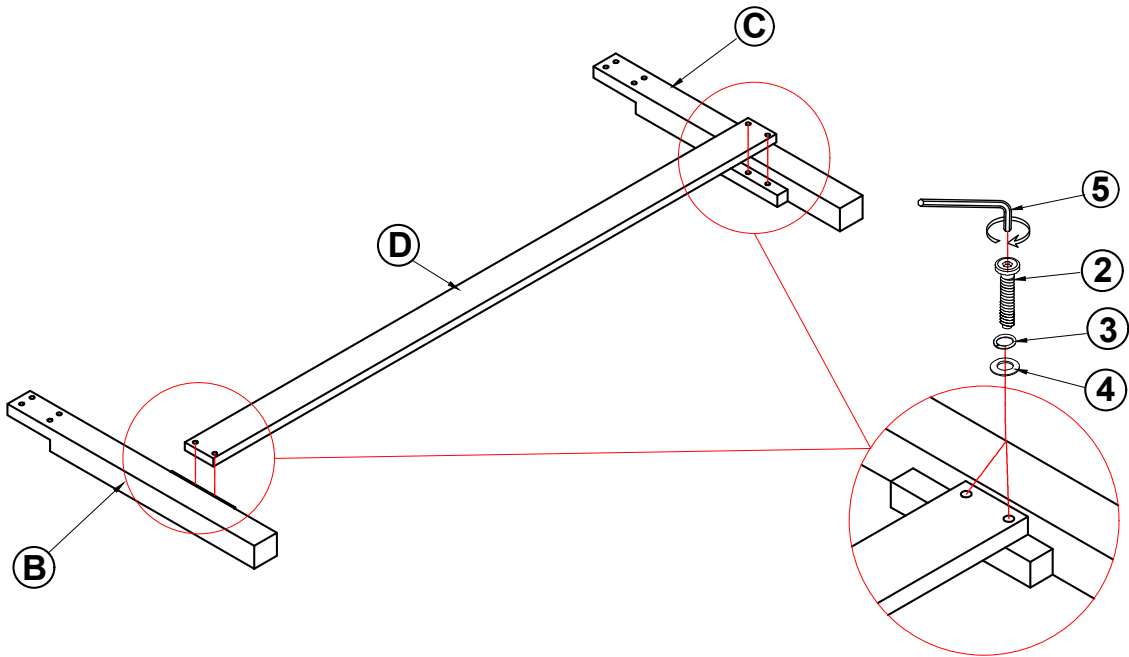

* BACK VIEW

STEP 2

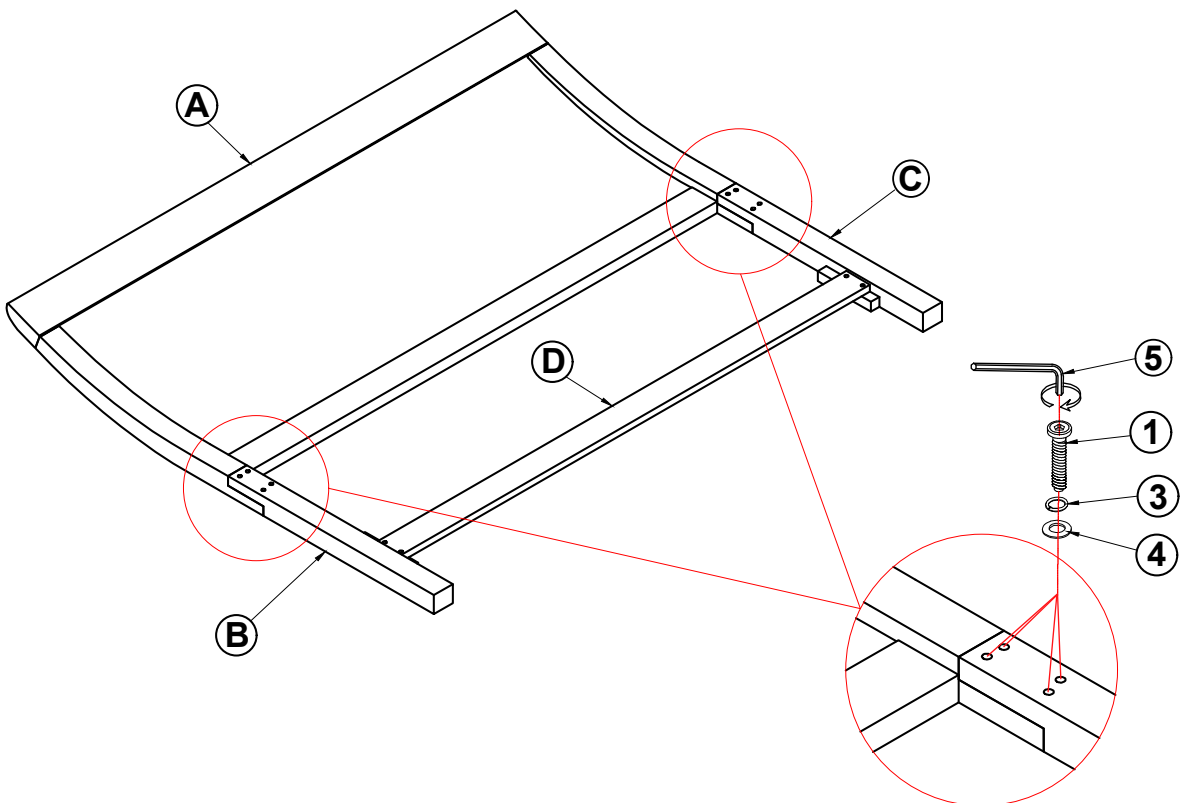

ITEM: 223471KW(B1-B3)



ASSEMBLY INSTRUCTIONS

STEP 3

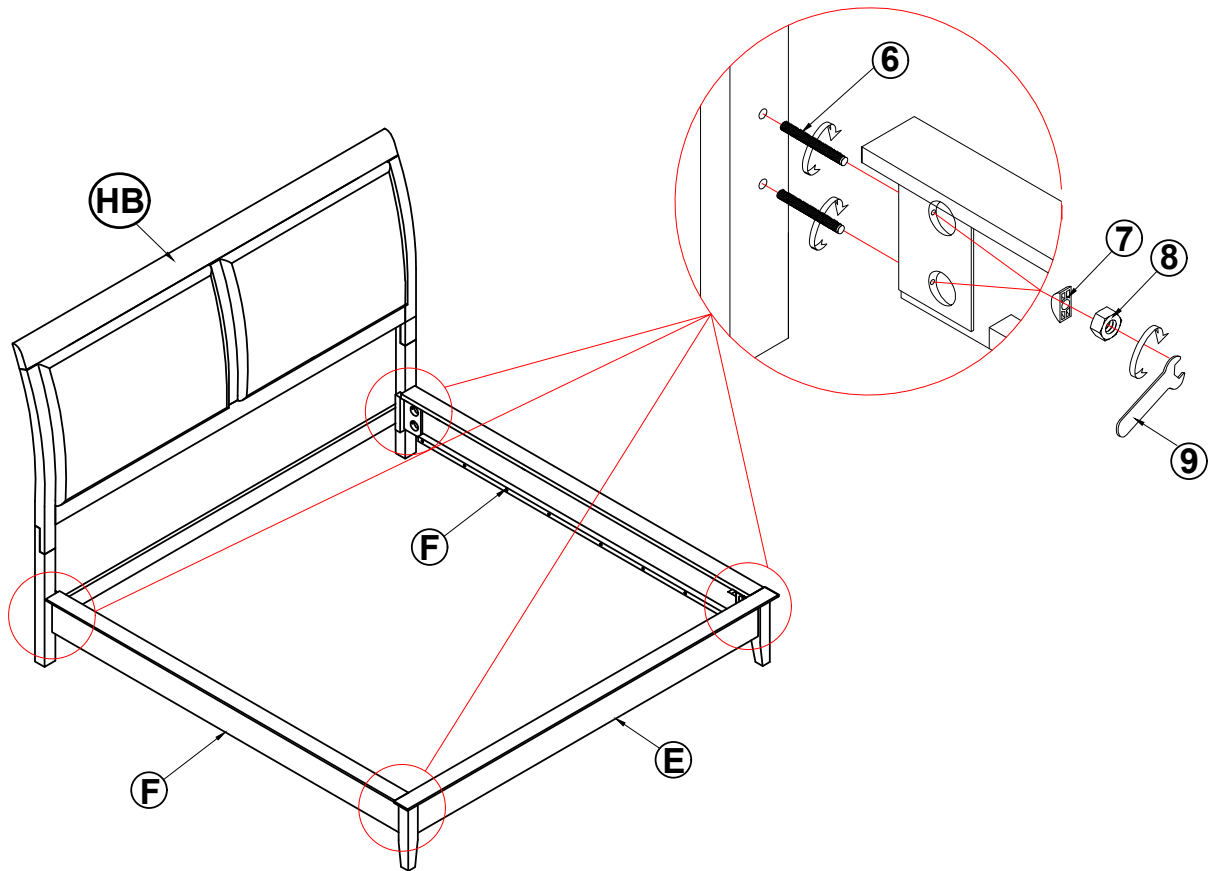

STEP 4

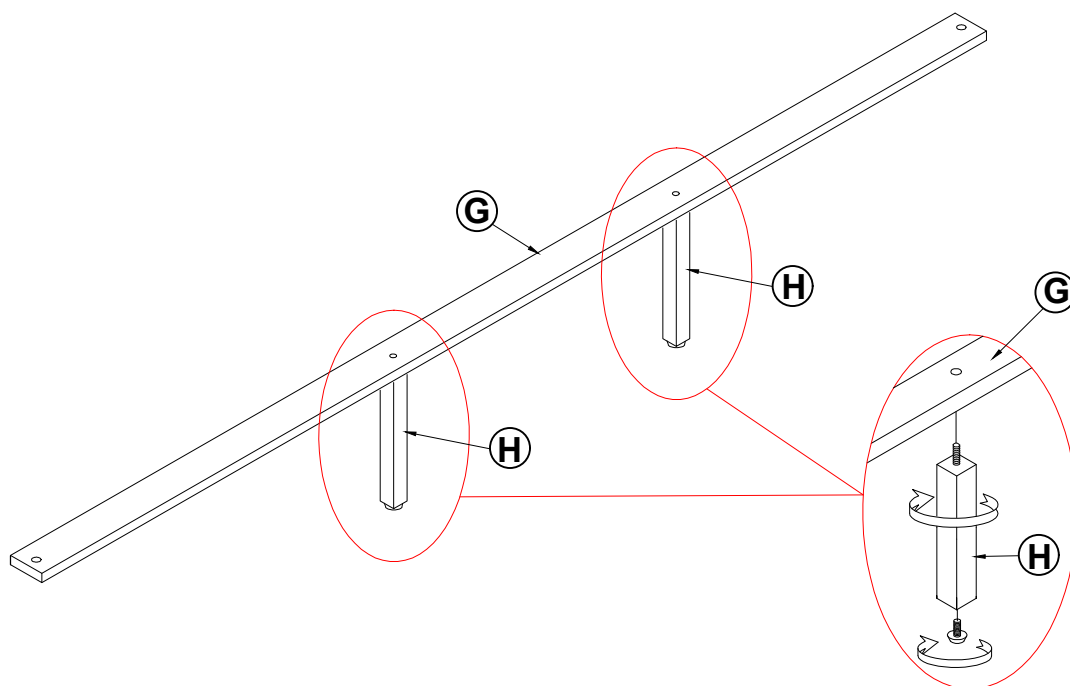

ITEM: 223471KW(B1-B3)

ASSEMBLY INSTRUCTIONS



STEP 5

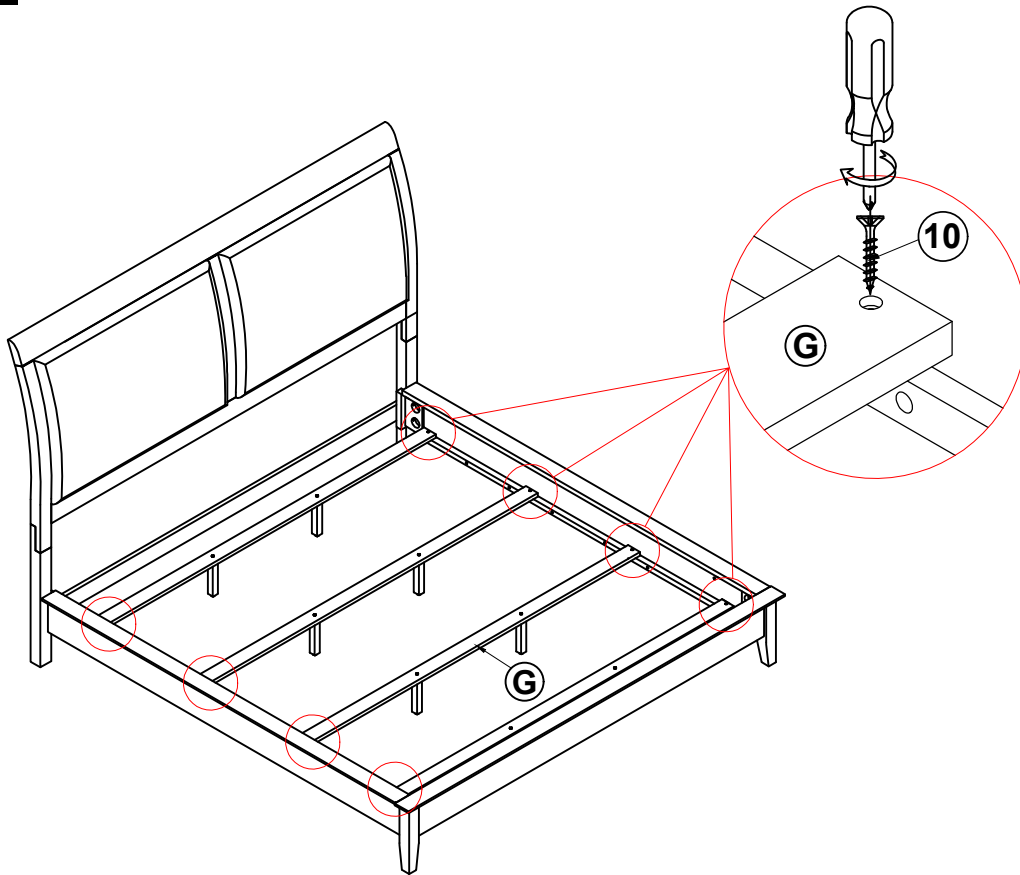

STEP 6

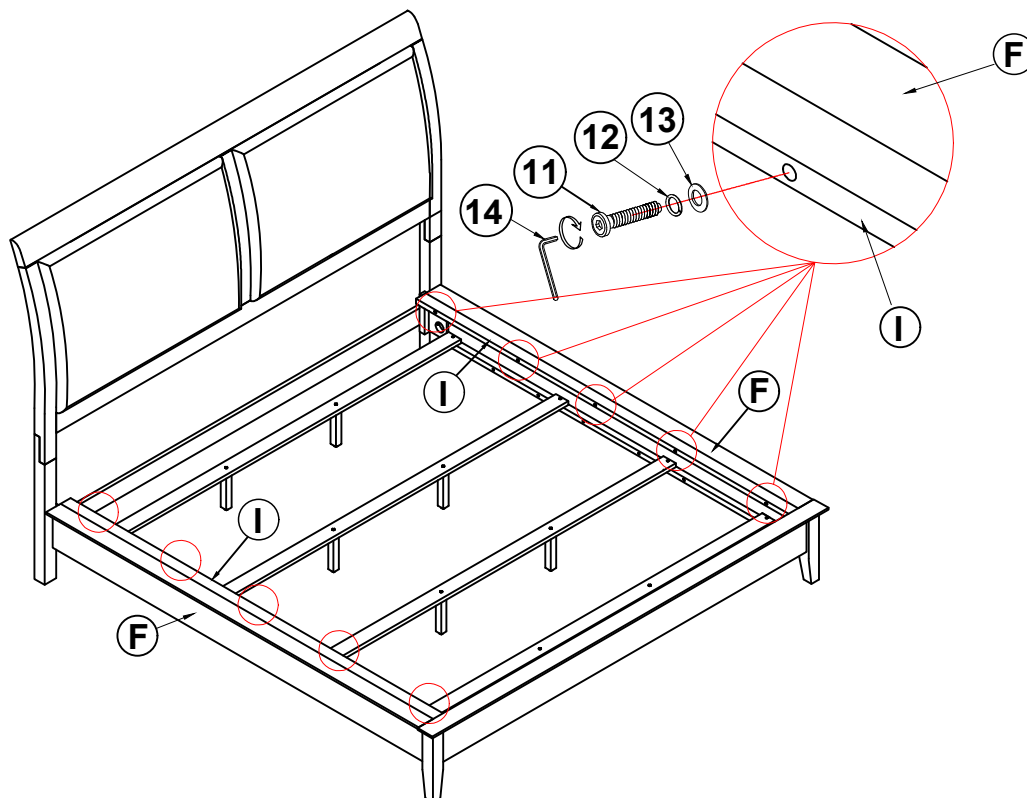

ITEM: **223471KW(B1-B3)**

ASSEMBLY INSTRUCTIONS



STEP 7

COMPLETE

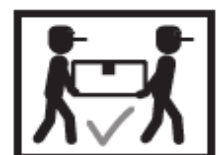
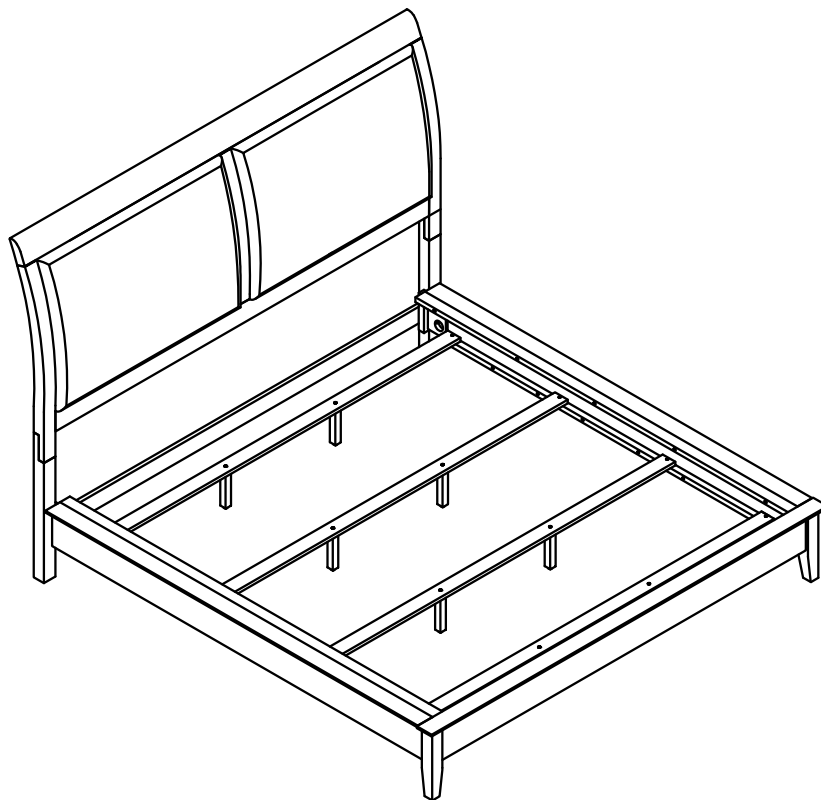

ITEM: 223471KW(B1-B3)



Inner Size : 85.50"W X 73.00"D

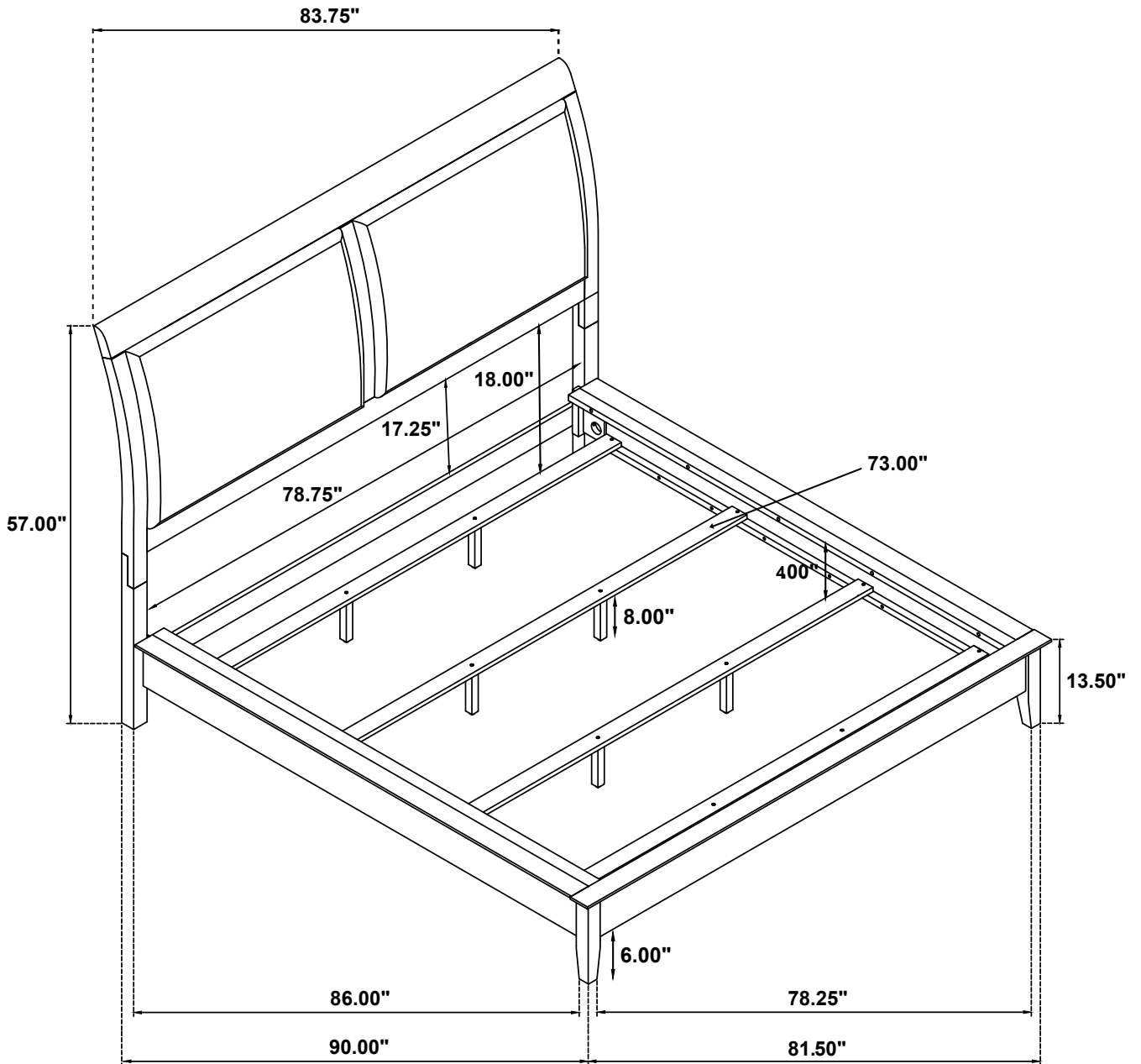

Note: Dimension tolerance $\pm 5\%$