



*ASSEMBLY INSTRUCTIONS*  
*COASTER FINE FURNITURE*



*Fine Furniture for every stage of life*

**223471Q (B1-B3)**  
***Queen Bed***

# ITEM: 223471Q(B1-B3)



## ASSEMBLY INSTRUCTIONS

### ASSEMBLY TIPS:

1. Remove hardware from box and sort by size.
2. Please check to see that all hardware and parts are present prior to start of assembly.
3. Please follow attached instructions in the same sequence as numbered to assure fast & easy assembly.



### WARNING!

1. Don't attempt to repair or modify parts that are broken or defective. Please contact the store immediately.
2. This product is for home use only and not intended for commercial establishments.







ASSEMBLY TIME

30 MINUTES

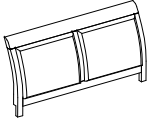
## PARTS IDENTIFICATION





### B1 (BOX 1)

A	HEADBOARD PANEL		1PC	B	RIGHT HEADBOARD LEG		1PC
C	LEFT HEADBOARD LEG		1PC	D	HEADBOARD BOTTOM RAIL		1PC

### B2 (BOX 2)

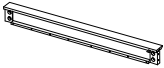
E	FOOTBOARD		1PC
---	-----------	---	-----

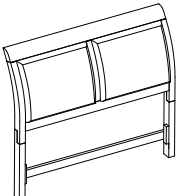
### B3 (BOX 3)

F	BED RAIL		2PCS	G	BED SLAT		4PCS
H	BED SLAT SUPPORT WITH LEVELER		8PCS				
HB	223471Q (B1) FROM BOX 1 HEADBOARD COMPLETE		1PC	FB	223471Q (B2) FROM BOX 2 FOOTBOARD		1PC

### NOTE:

Phillips head screw driver is required in the assembly process; however, manufacturer does not provide this item.

# ITEM: 223471Q(B1-B3)



## ASSEMBLY INSTRUCTIONS

### ASSEMBLY TIPS:

1. Remove hardware from box and sort by size.
2. Please check to see that all hardware and parts are present prior to start of assembly.
3. Please follow attached instructions in the same sequence as numbered to assure fast & easy assembly.





### WARNING!





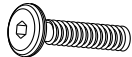

1. Don't attempt to repair or modify parts that are broken or defective. Please contact the store immediately.
2. This product is for home use only and not intended for commercial establishments.

## HARDWARE IDENTIFICATION

### Z-B1 (BOX 1) - HARDWARE PACK IS LOCATED IN 223471Q (B1)

1	<b>LONG BOLT</b> ( $\varnothing$ 5/16" x 45MM - RBW)		8PCS	4	<b>FLAT WASHER</b> ( $\varnothing$ 5/16" - RBW)		12PCS
2	<b>SHORT BOLT</b> ( $\varnothing$ 5/16" x 35MM - RBW)		4PCS	5	<b>ALLEN WRENCH</b> (4MM - RBW)		1PC
3	<b>LOCK WASHER</b> ( $\varnothing$ 5/16" - RBW)		12PCS				

### Z-B3 (BOX 3) - HARDWARE PACK IS LOCATED IN 223471Q (B3)

6	<b>THREADED BOLT</b> ( $\varnothing$ 5/16" x 90MM - RBW)		8PCS	9	<b>WRENCH</b> (14MM - RBW)		1PC
7	<b>HALF ROUND NUT</b> ( $\varnothing$ 5/16" - RBW)		8PCS	10	<b>FLAT HEAD SCREW</b> ( $\varnothing$ 4 x 30MM - RBW)		8PCS
8	<b>HEX NUT</b> ( $\varnothing$ 5/16" x 14MM - RBW)		8PCS				

### NOTE:

Phillips head screw driver is required in the assembly process; however, manufacturer does not provide this item.

# ITEM: 223471Q(B1-B3)

## ASSEMBLY INSTRUCTIONS



### STEP 1

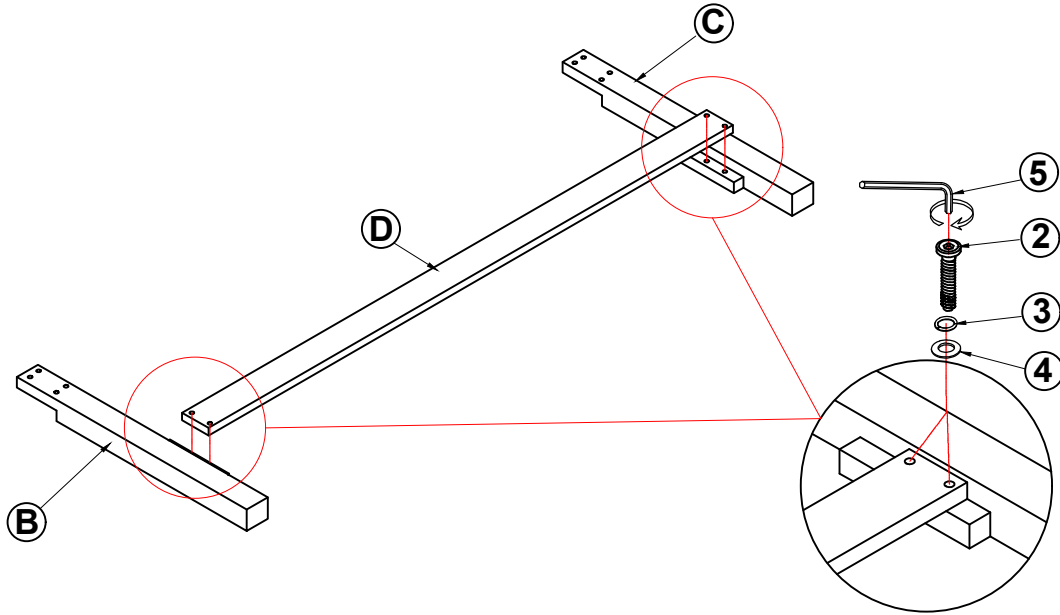

\* BACK VIEW

### STEP 2

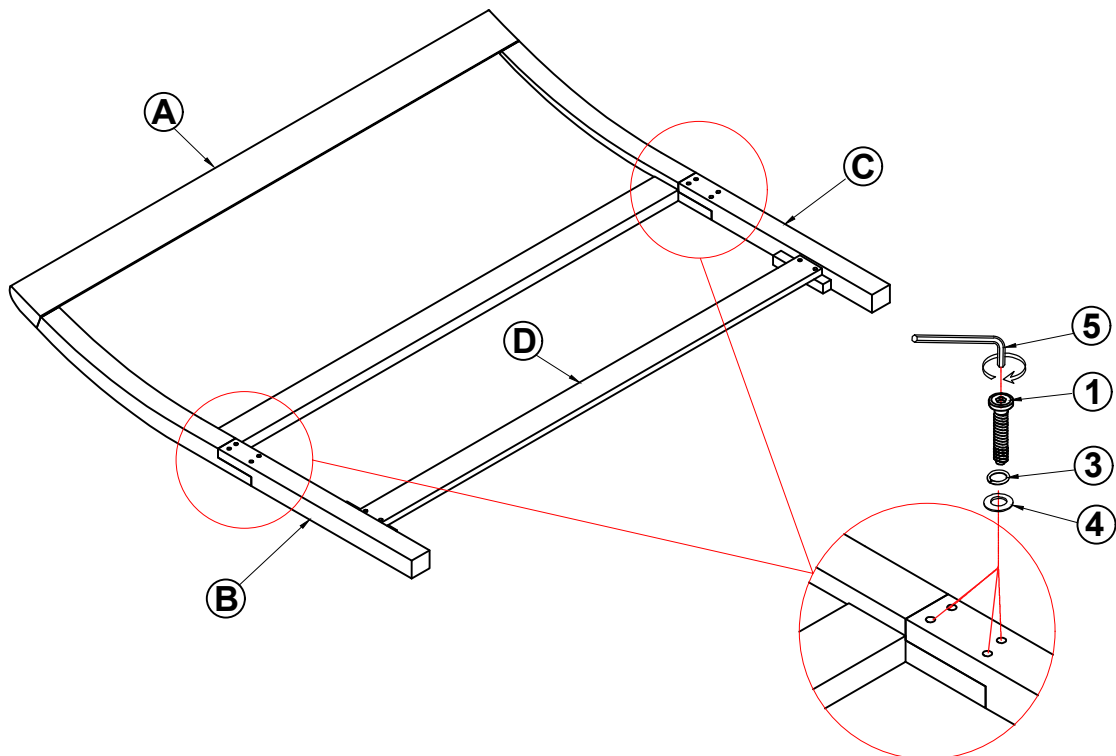

# ITEM: 223471Q(B1-B3)

## ASSEMBLY INSTRUCTIONS



### STEP 3

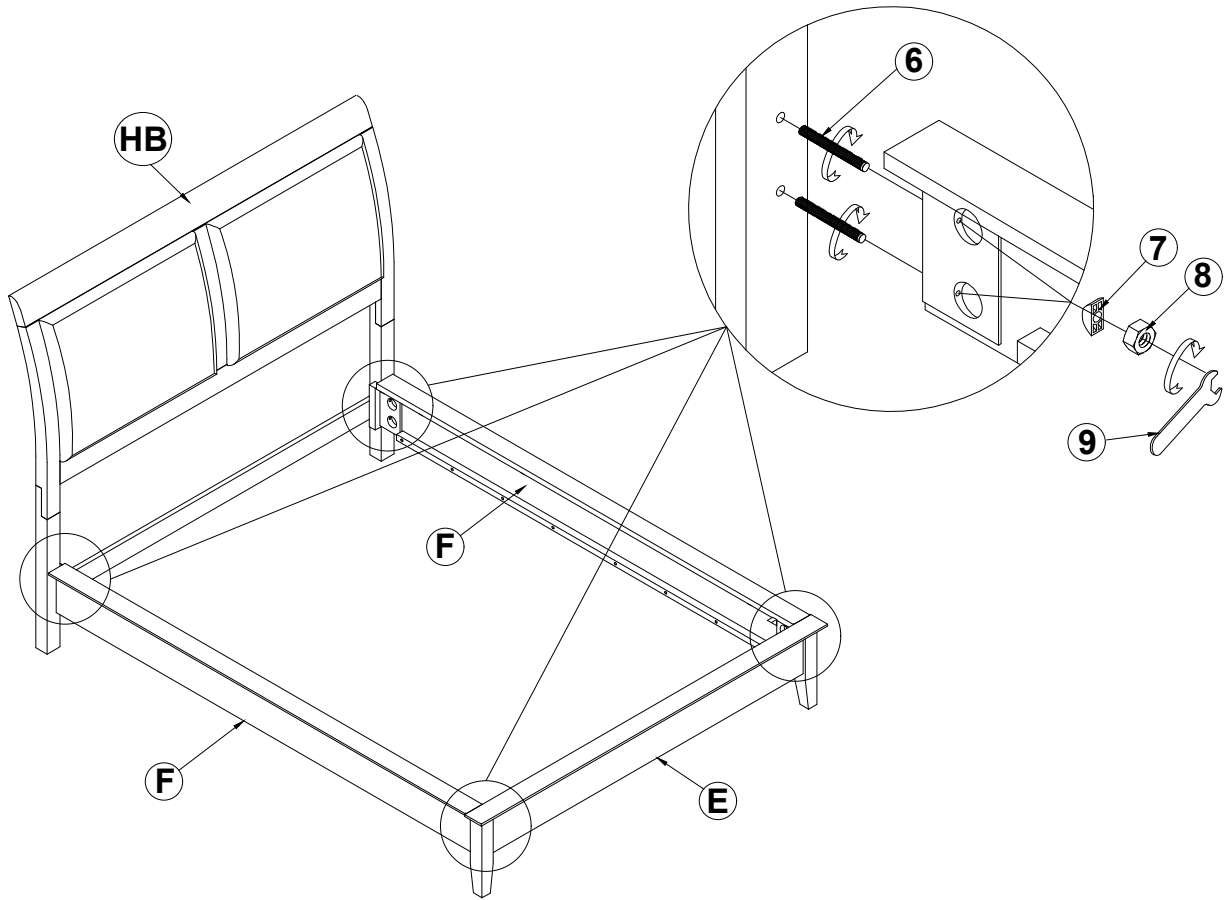

### STEP 4

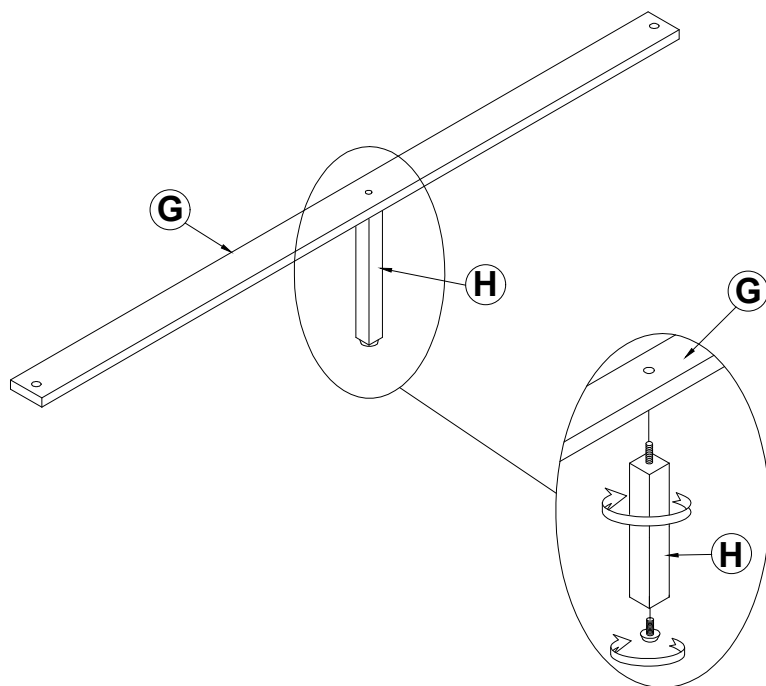

ITEM: **223471Q(B1-B3)**

**ASSEMBLY INSTRUCTIONS**



**STEP 5**

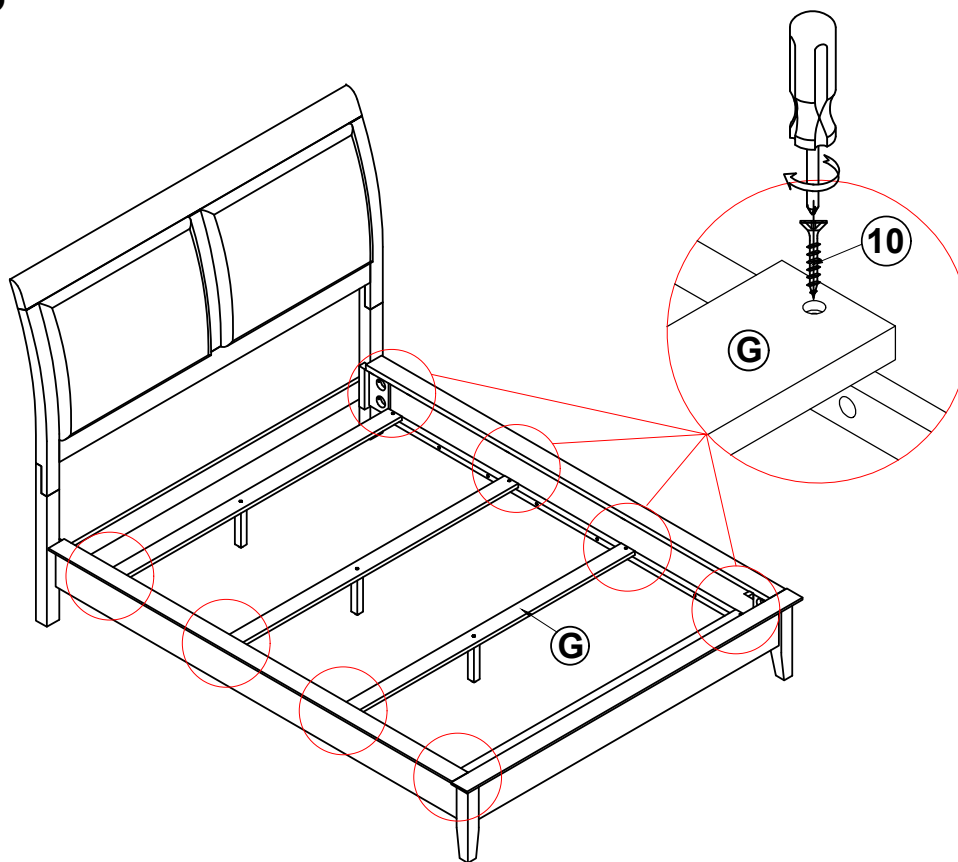

**STEP 6**  
**COMPLETE**

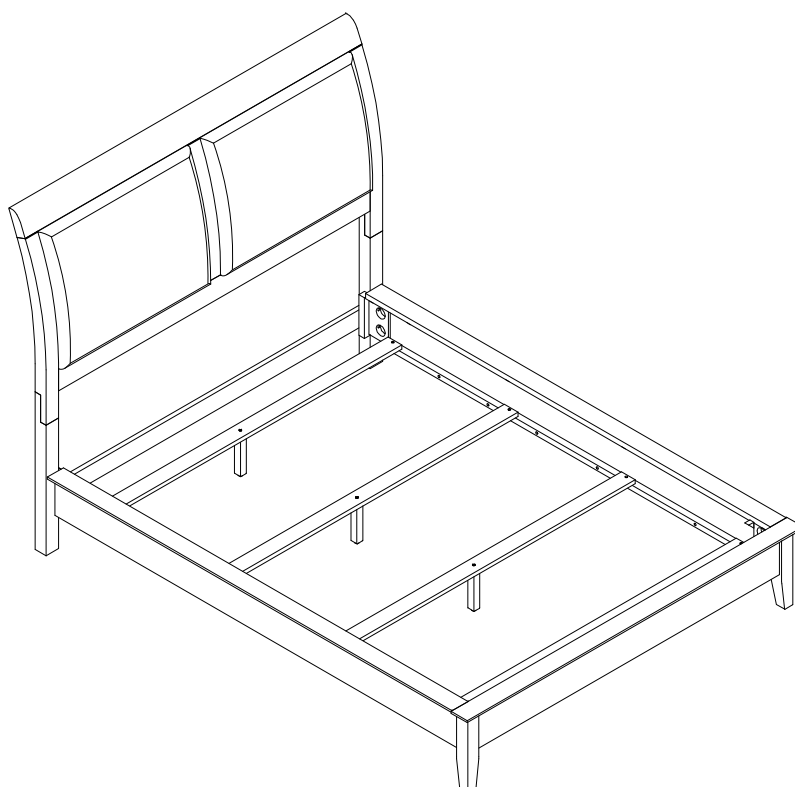

ITEM: **223471Q(B1-B3)**



Inner Size : 81.50"W X 61.00"D

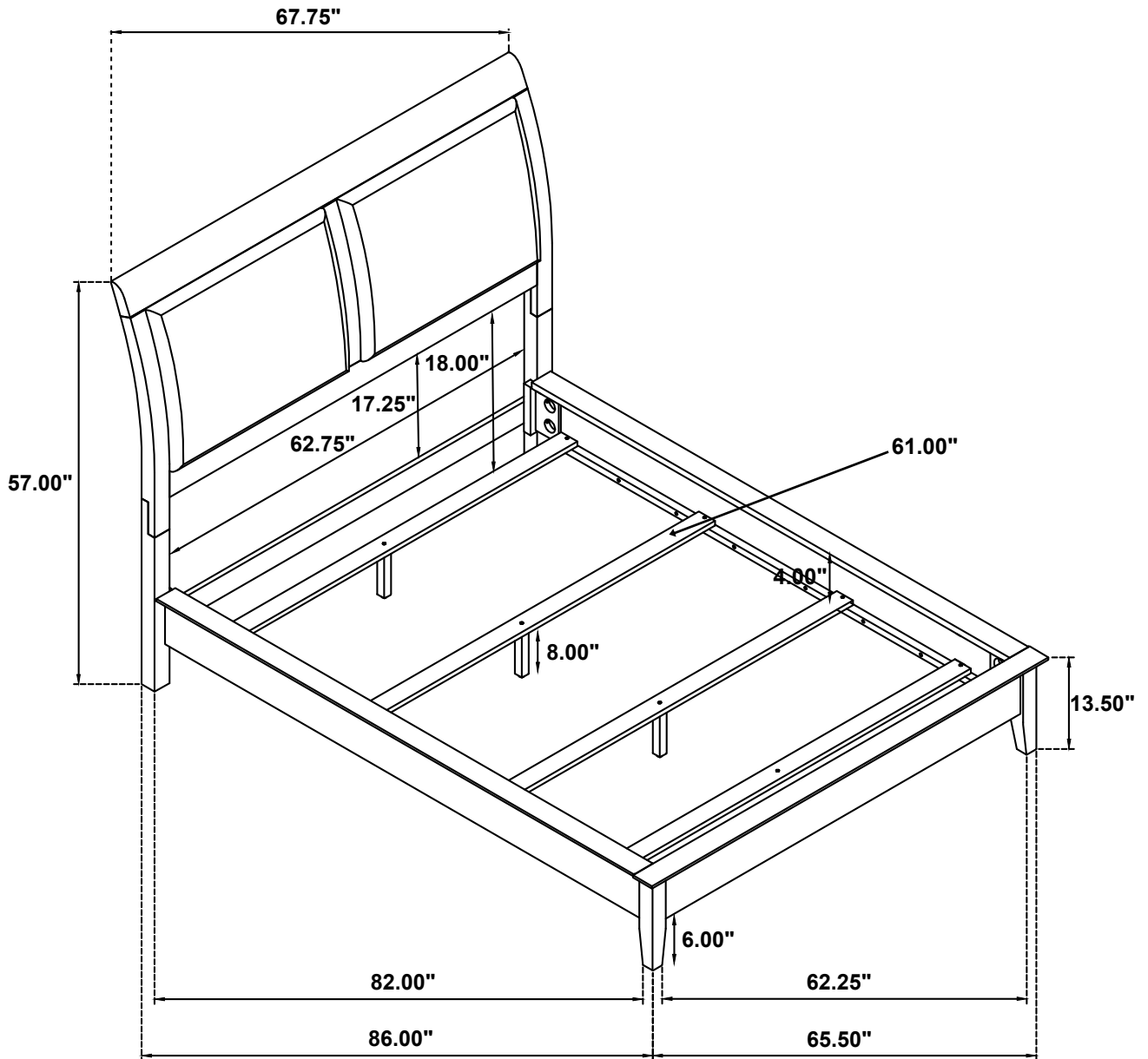

Note: Dimension tolerance  $\pm 5\%$