

ASSEMBLY INSTRUCTIONS
COASTER FINE FURNITURE

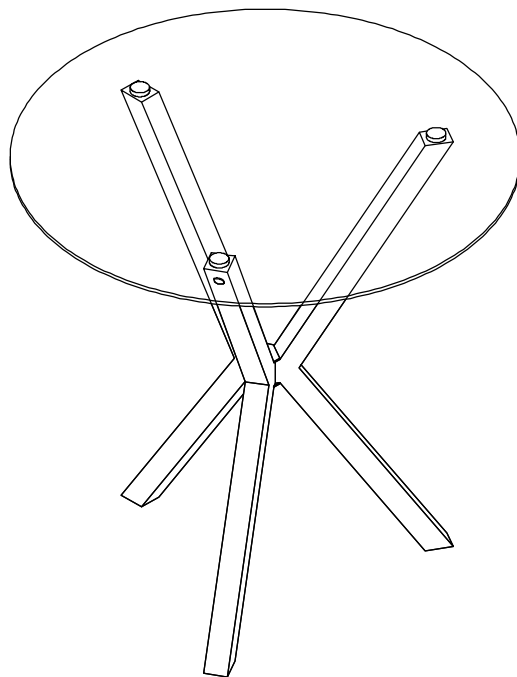

Fine Furniture for every stage of life

100186
BAR TABLE

REVISION 0 : 12/12/2019
REVISION 1 : 07/18/2024

ITEM:100186



ASSEMBLY INSTRUCTIONS

ASSEMBLY TIPS:

1. Remove hardware from box and sort by size.
2. Please check to see that all hardware and parts are present prior to start of assembly.
3. Please follow attached instructions in the same sequence as numbered to assure fast & easy assembly.



WARNING!

1. Don't attempt to repair or modify parts that are broken or defective. Please contact the store immediately.
2. This product is for home use only and not intended for commercial establishments.



ASSEMBLY TIME 15 MINUTES

PARTS IDENTIFICATION

B1: TOP

AN GLASS TOP

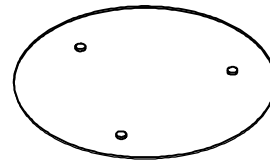

1PC

B2: BASE

BN METAL LEG



3PCS

CN TRIANGLE TOP COVER

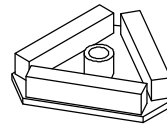

1PC

DN TRIANGLE BOTTOM COVER

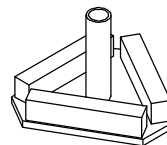

1PC

ZN

HARDWARE IDENTIFICATION

1 SHORT BOLT
(ϕ 1/4" x 35mm SR)



3PCS

2 LONG BOLT
(ϕ 1/4" x 56mm SR)



1PC

3 ADHESIVE



3PCS

4 CAP



3PCS

5 ALLEN WRENCH
(4mm)

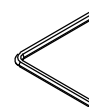

1PC

ITEM:100186

ASSEMBLY INSTRUCTIONS

STEP 1 Do not tighten until each step is completed or instructed.

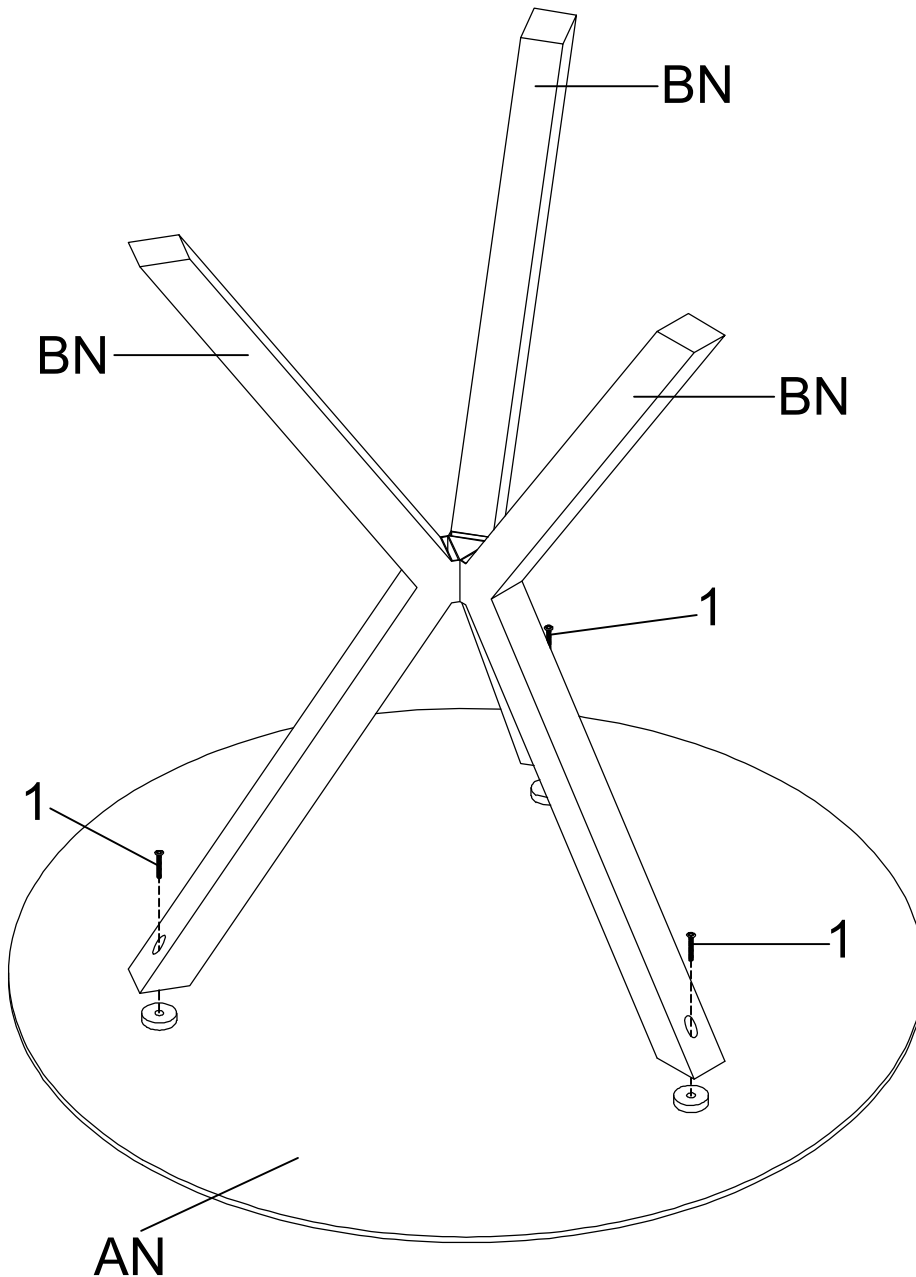

ITEM:100186

ASSEMBLY INSTRUCTIONS

STEP 2

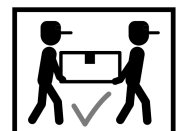
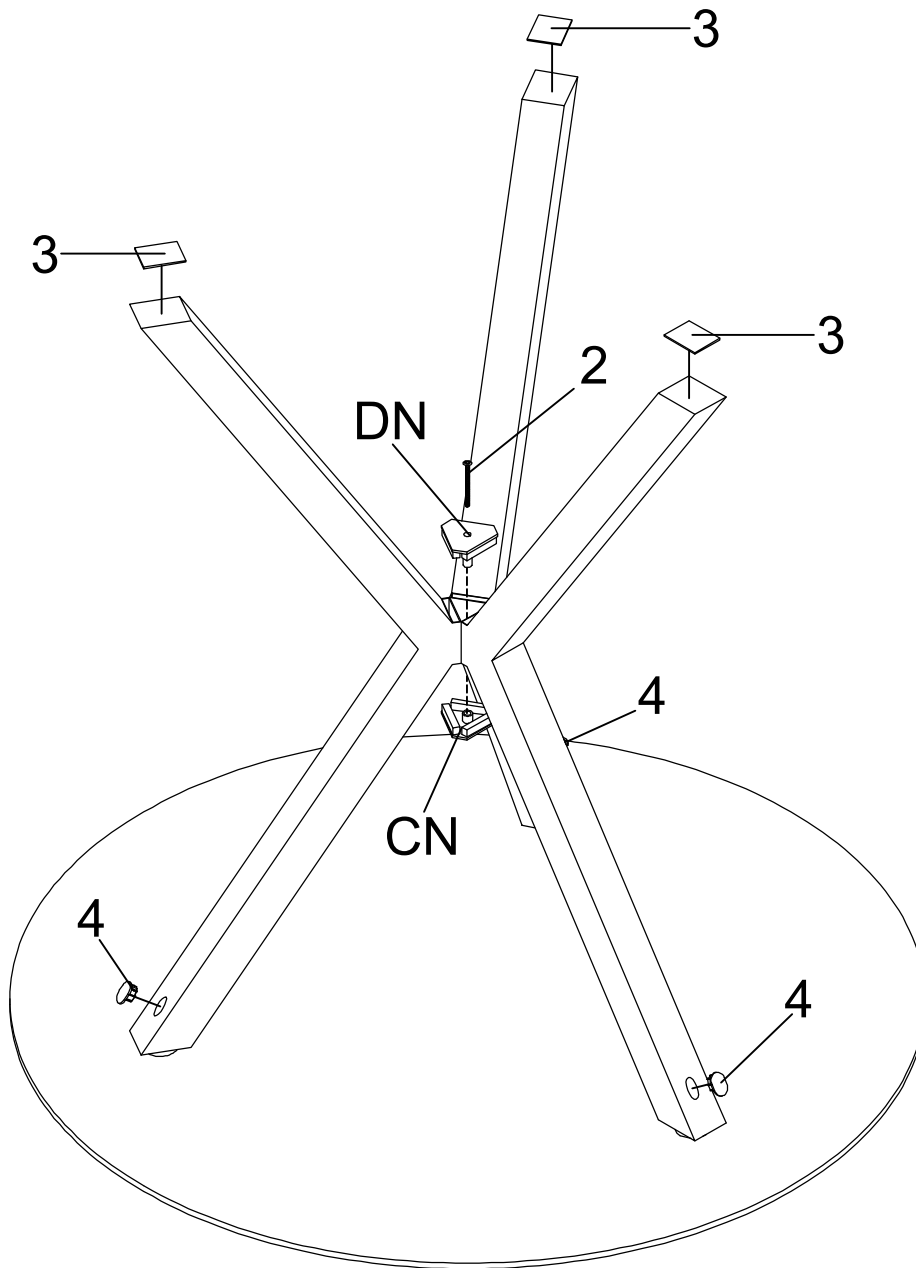

ITEM:100186 ASSEMBLY INSTRUCTIONS



Product Size : 889 DIA X 1048H (MM)
Product Size : 35" DIA X 41 ¹/₄"

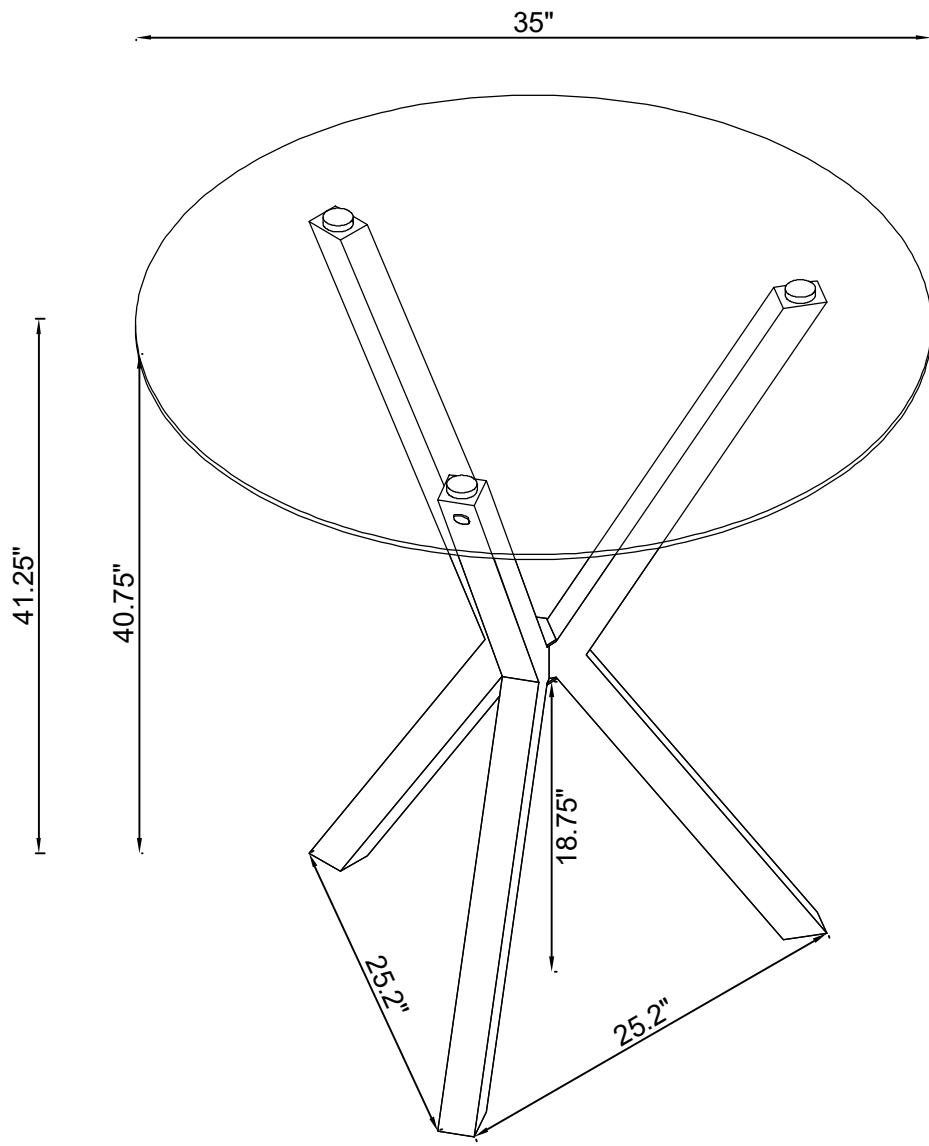

Note : Dimension tolerance $\pm 5\%$