

**ASSEMBLY INSTRUCTIONS**  
**COASTER FINE FURNITURE**



*Fine Furniture for every stage of life*

**301405Q(B1&B2)**  
**Queen Bed**

# ITEM: 301405Q(B1&B2)



## ASSEMBLY INSTRUCTIONS

### ASSEMBLY TIPS:

1. Remove hardware from box and sort by size.
2. Please check to see that all hardware and parts are present prior to start of assembly.
3. Please follow attached instructions in the same sequence as numbered to assure fast & easy assembly.



### WARNING!

1. Don't attempt to repair or modify parts that are broken or defective. Please contact the store immediately.
2. This product is for home use only and not intended for commercial establishments.



ASSEMBLY TIME

15 MINUTES

## PARTS IDENTIFICATION

### B1(BOX1)

A HEADBOARD PANEL

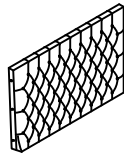

1PC

C RIGHT HEADBOARD LEG



1PC

E RIGHT WOOD CLEAT

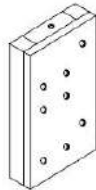

1PC

### B2(BOX2)

F FOOTBOARD LEG



2PCS

H RIGHT BED RAIL



1PC

J BED SLAT



4PCS

HB 301405Q(B1)  
FROM BOX1  
HEADBOARD  
COMPLETE

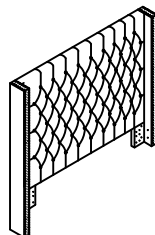

1PC

B LEFT HEADBOARD LEG



1PC

D LEFT WOOD CLEAT

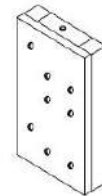

1PC

G LEFT BED RAIL



1PC

I FOOTBOARD PANEL

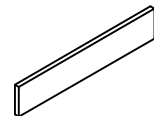

1PC

K BED SLAT SUPPORT WITH LEVELER

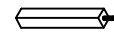

4PCS

FB 301405Q(B2)  
FROM BOX2  
FOOTBOARD  
COMPLETE

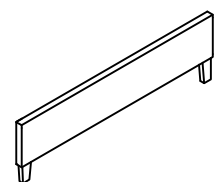

1PC

# ITEM: 301405Q(B1&B2)

## ASSEMBLY INSTRUCTIONS

### ASSEMBLY TIPS:

1. Remove hardware from box and sort by size.
2. Please check to see that all hardware and parts are present prior to start of assembly.
3. Please follow attached instructions in the same sequence as numbered to assure fast & easy assembly.







### WARNING!





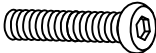

1. Don't attempt to repair or modify parts that are broken or defective. Please contact the store immediately.
2. This product is for home use only and not intended for commercial establishments.

## HARDWARE IDENTIFICATION

### Z-B1(BOX1)-HARDWARE PACK IS LOCATED IN 301405Q(B1)

|   |                                 |   |       |   |                                  |   |       |
|---|---------------------------------|---|-------|---|----------------------------------|---|-------|
| 1 | ALLEN WRENCH<br>(5MM-BLK)       |    | 1PC   | 2 | FLAT WASHER<br>(Ø5/16" -BLK)     |  | 20PCS |
| 3 | LONG BOLT<br>(Ø5/16"x 50mm-BLK) |    | 14PCS | 4 | SHORT BOLT<br>(Ø5/16"x 40mm-BLK) |  | 6PCS  |
| 5 | LOCK WASHER<br>(Ø5/16" -BLK)    |  | 20PCS |   |                                  |   |       |

### Z-B2(BOX2)-HARDWARE PACK IS LOCATED IN 301405Q(B2)

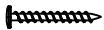
|    |                              |   |       |    |                                     |   |       |
|----|------------------------------|---|-------|----|-------------------------------------|---|-------|
| 6  | ALLEN WRENCH<br>(5MM-BLK)    |  | 1PC   | 7  | FLAT WASHER<br>(Ø5/16" -BLK)        |  | 12PCS |
| 8  | BOLT<br>(Ø5/16"x 70mm-BLK)   |  | 4PCS  | 9  | THREADED BOLT<br>(Ø5/16"x 90mm-BLK) |  | 8PCS  |
| 10 | LOCK WASHER<br>(Ø5/16" -BLK) |  | 12PCS | 11 | HEX NUT<br>(Ø5/16" -BLK)            |  | 8PCS  |
| 12 | WRENCH<br>(BLK)              |  | 1PC   | 13 | FLAT HEAD SCREW<br>(m4x30mm-BLK)    |  | 8PCS  |

### NOTE:

Phillips head screw driver is required in the assembly process; however, manufacturer does not provide this item.





ITEM: **301405Q(B1&B2)**  
**ASSEMBLY INSTRUCTIONS**  
**STEP 4**  
**COMPLETE**

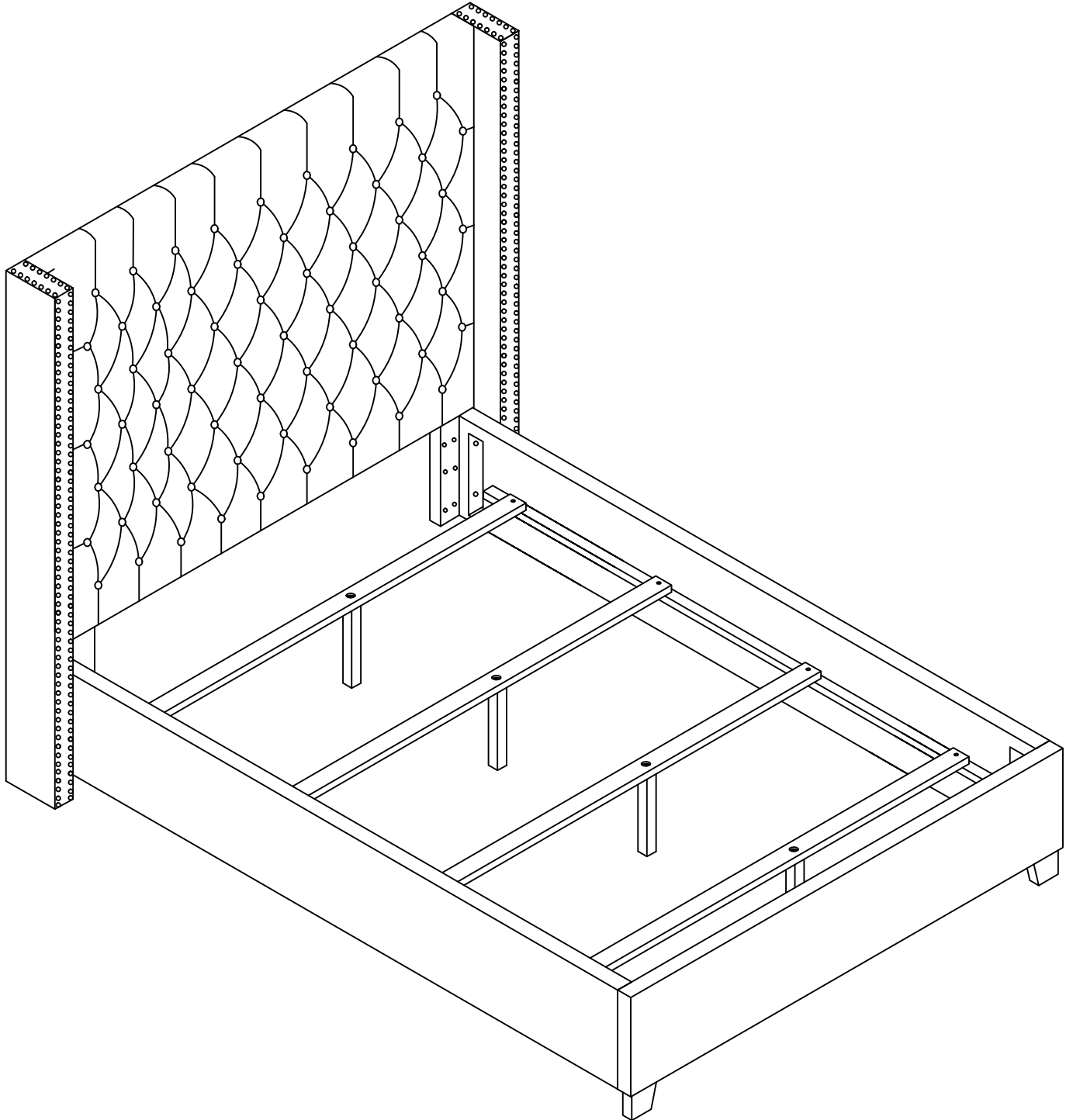

ITEM: **301405Q(B1&B2)**

**ASSEMBLY HEADBOARD TO METAL FRAME  
COMPLETE**

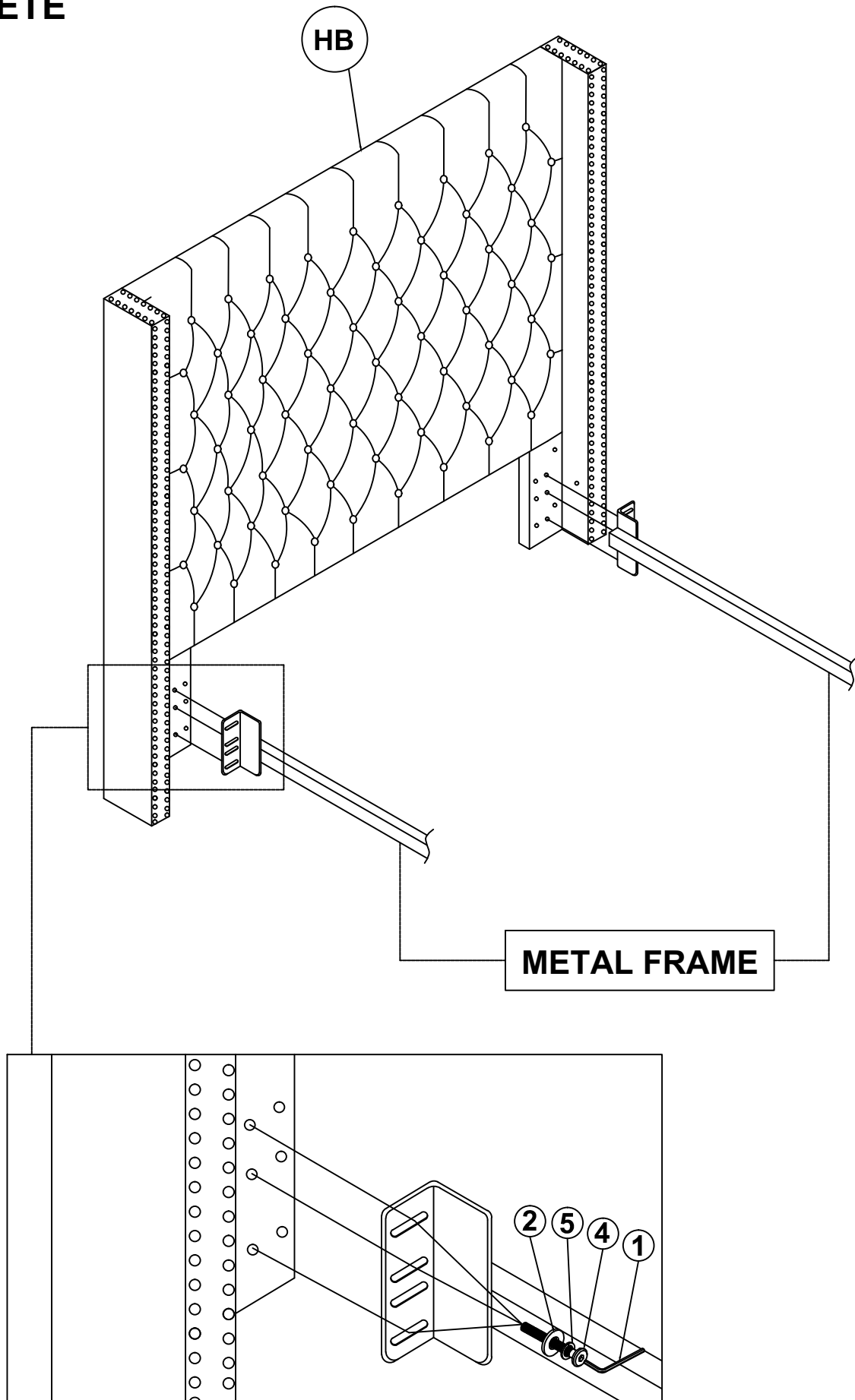

ITEM:301405Q(B1&B2)



Inner Size: 61.25"W X 81.00"D

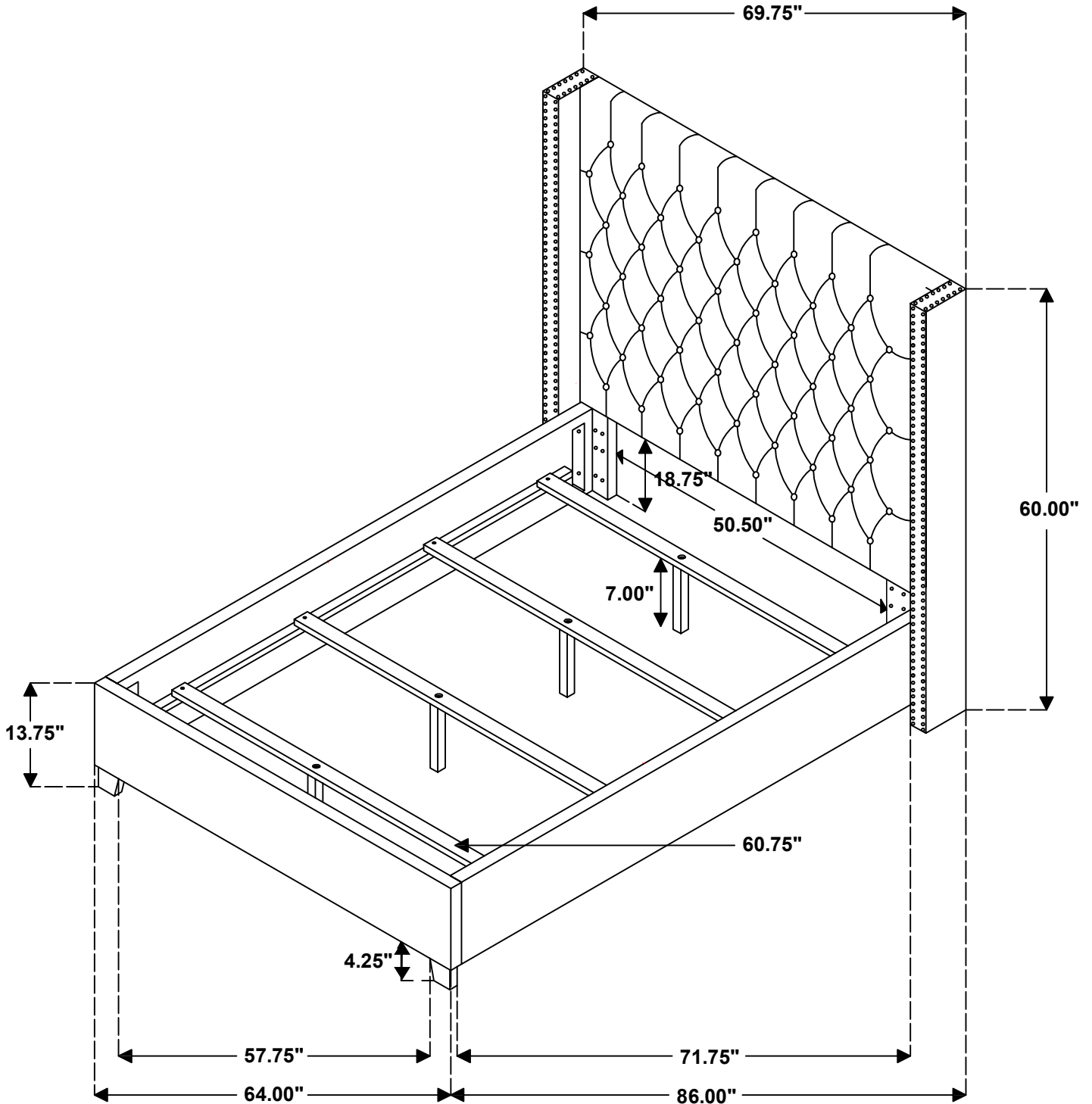

Note: Dimension tolerance  $\pm 5\%$