

ASSEMBLY INSTRUCTIONS
COASTER FINE FURNITURE



Fine Furniture for every stage of life

106440
DINING TABLE

REVISION 0 : 08/18/2017
REVISION 1 : 12/10/2024

ITEM:106440



ASSEMBLY INSTRUCTIONS

ASSEMBLY TIPS:

1. Remove hardware from box and sort by size.
2. Please check to see that all hardware and parts are present prior to start of assembly.
3. Please follow attached instructions in the same sequence as numbered to assure fast & easy assembly.



WARNING!

1. Don't attempt to repair or modify parts that are broken or defective. Please contact the store immediately.
2. This product is for home use only and not intended for commercial establishments.

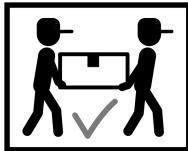

ASSEMBLY TIME 30 MINUTES

PARTS IDENTIFICATION

B1: Top

A GLASS

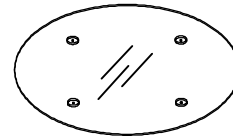

1PC

B2: Base

B LEG

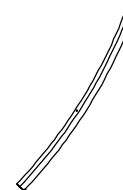

4PCS

Z

HARDWARE IDENTIFICATION

1 SHORT BOLT
(5/16" x 10mm SR)



4PCS

2 LONG BOLT
(5/16" x 63mm SR)



4PCS

3 LEVELER
(5/16" x 18mm BLK)



4PCS

4 CAP
(25 x 50mm SR)



4PCS

5 WASHER
(ø19mm SR)



4PCS

6 ALLEN WRENCH
(4mm)



1PC

HARDWARE PACK IS LOCATED IN 106440B2

ITEM: 106440

ASSEMBLY INSTRUCTIONS



STEP 1 Do not tighten until each step is completed or instructed.

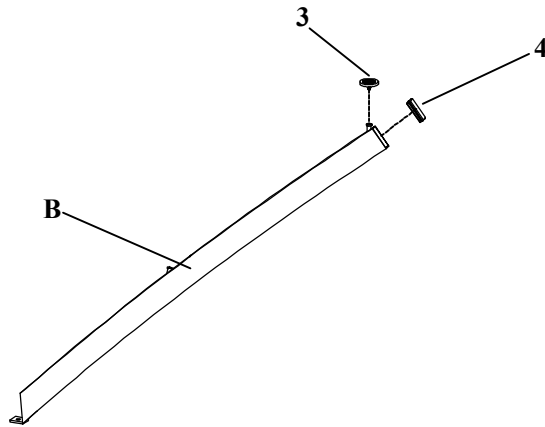

STEP 2

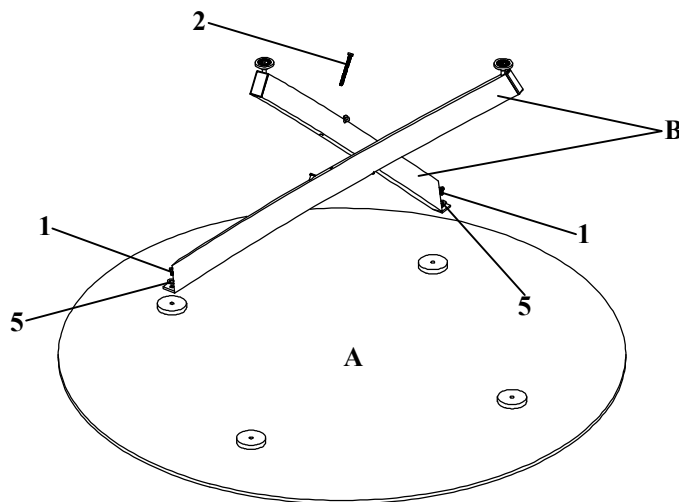

ITEM: 106440

ASSEMBLY INSTRUCTIONS

STEP 3

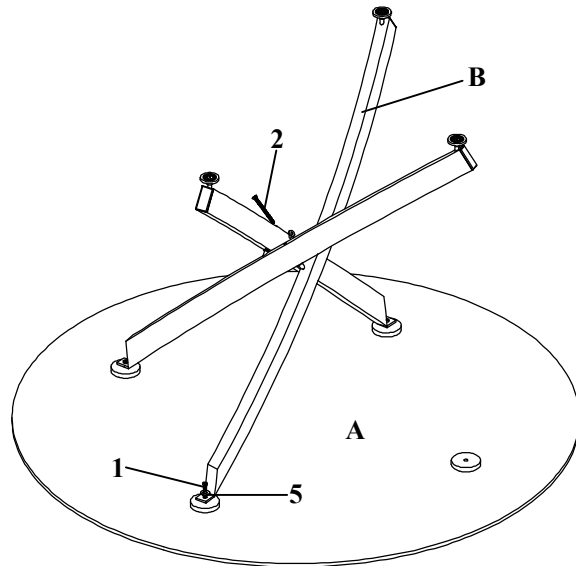

STEP 4

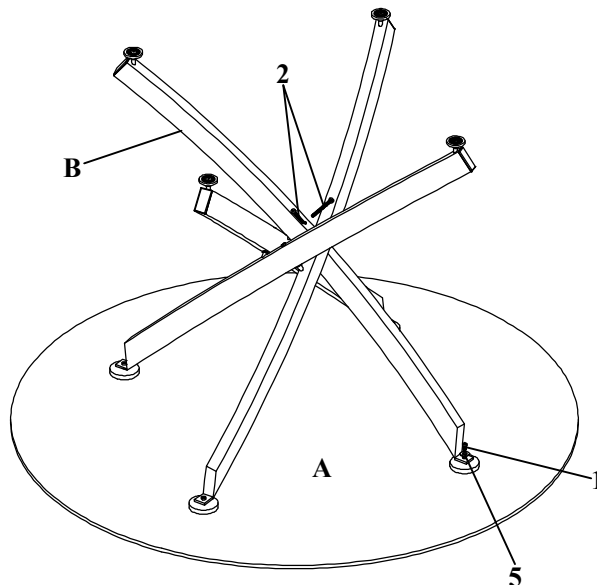

COMPLETE

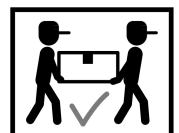
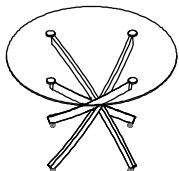

ITEM:106440 ASSEMBLY INSTRUCTIONS



Product Size : 1168 DIA X 750H (MM)
Product Size : 46" DIA X 29 1/2"

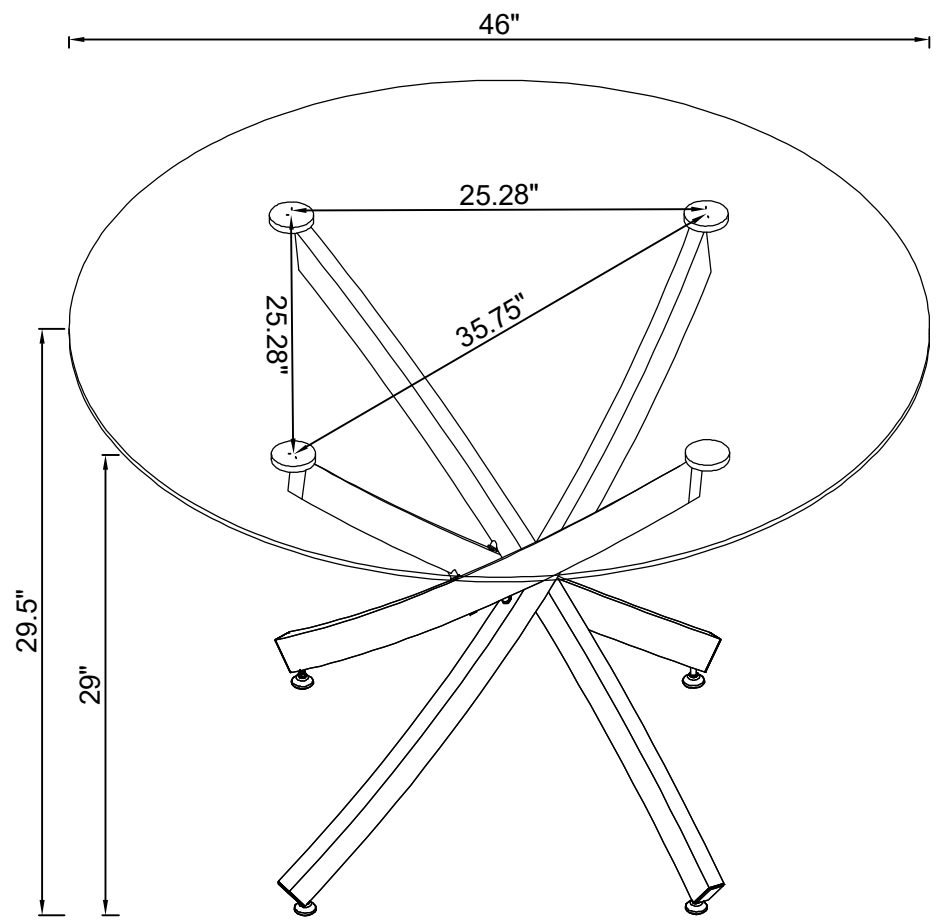

Note : Dimension tolerance $\pm 5\%$