

*ASSEMBLY INSTRUCTIONS*  
*COASTER FINE FURNITURE*



*Fine Furniture for every stage of life*

**100135**  
**BAR TABLE**

REVISION 0 : 10/13/2017  
REVISION 1 : 05/29/2019  
REVISION 2 : 07/24/2023  
REVISION 3 : 12/13/2024

PAGE 1 OF 9

COASTERFURNITURE.COM

ITEM:100135



# ASSEMBLY INSTRUCTIONS

## ASSEMBLY TIPS:

1. Remove hardware from box and sort by size.
2. Please check to see that all hardware and parts are present prior to start of assembly.
3. Please follow attached instructions in the same sequence as numbered to assure fast & easy assembly.



### WARNING!

1. Don't attempt to repair or modify parts that are broken or defective. Please contact the store immediately.
2. This product is for home use only and not intended for commercial establishments.

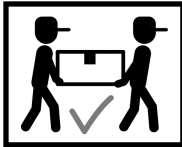

ASSEMBLY TIME 60 MINUTES

## PARTS IDENTIFICATION

A LEFT LEG

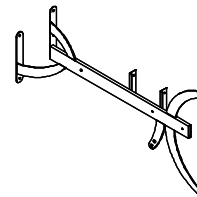

1PC

B RIGHT LEG

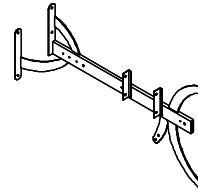

1PC

C FRONT FRAME



1PC

D HANGER BRACKET

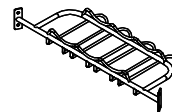

1PC

E BOTTOM SUPPORT

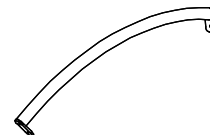

1PC

F GLASS SHELF SUPPORT



2PCS

ITEM:100135

# ASSEMBLY INSTRUCTIONS

## PARTS IDENTIFICATION



G UPPER TOP GLASS

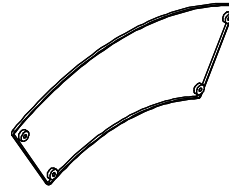

1PC

H GLASS SHELF

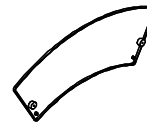

2PCS

I LOWER TOP GLASS

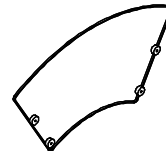

1PC

## HARDWARE IDENTIFICATION

1 ALLEN BOLT-MEDIUM  
(1/4" x 8mm SR)



22PCS

2 ALLEN BOLT-SMALL  
(1/4" x 9mm SR)



4PCS

3 BOLT  
(3/16" x 12mm SR)



4PCS

4 SMALL WASHER  
( $\phi$ 15mm)



4PCS

5 SUCTION CUP  
(6mm)



4PCS

6 FLOOR LEVELER  
(1/4" x 6mm BLK)



4PCS

7 ALLEN BOLT-LARGE  
(1/4" x 38mm SR)



3PCS

8 NUT  
(1/4" SR)



3PCS

9 WASHER  
( $\phi$ 16mm SR)



3PCS

10 PLASTIC WASHER  
( $\phi$ 26mm)



3PCS

11 ALLEN WRENCH  
(4mm)



1PC

12 HEXAGONAL WRENCH  
(1/4")



1PC

NOTE: PART 7,8,9,AND 10 ARE NEEDED ONLY WHEN BUYING 2 UNITS

# ITEM:100135 ASSEMBLY INSTRUCTIONS



**STEP 1** Do not tighten until each step is completed or instructed.

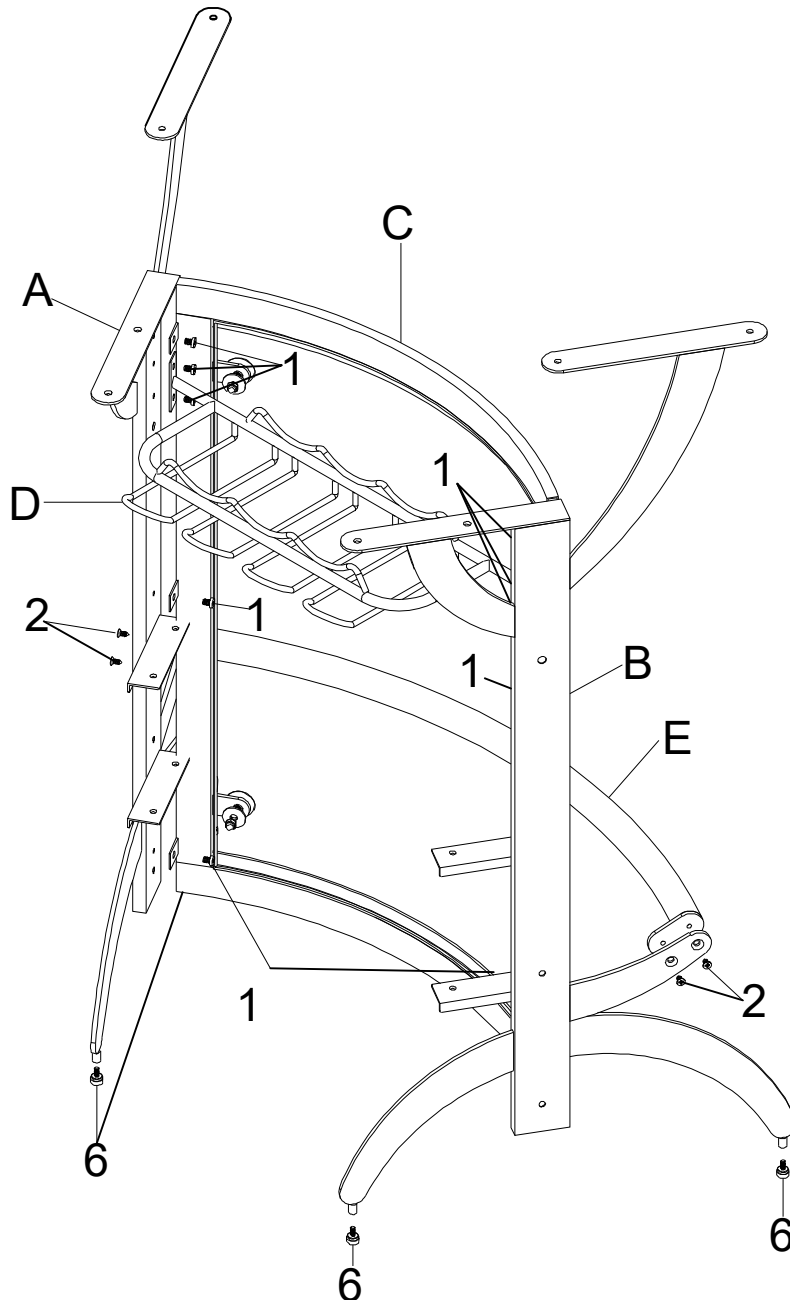

ITEM:100135  
ASSEMBLY INSTRUCTIONS  
STEP 2

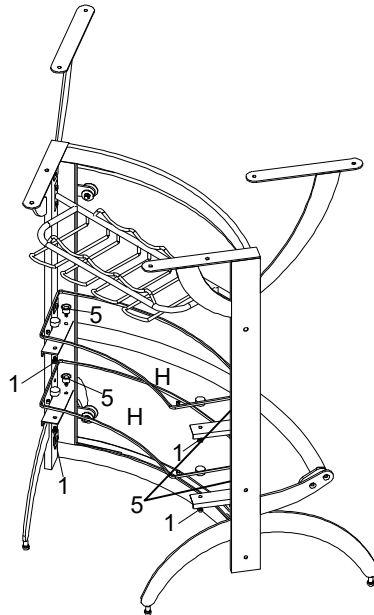

STEP 3

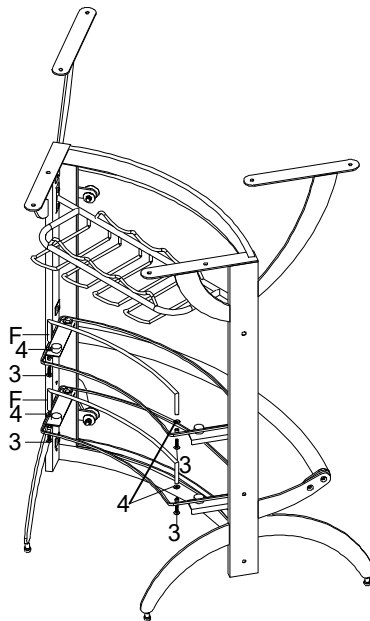

ITEM:100135  
ASSEMBLY INSTRUCTIONS  
STEP 4

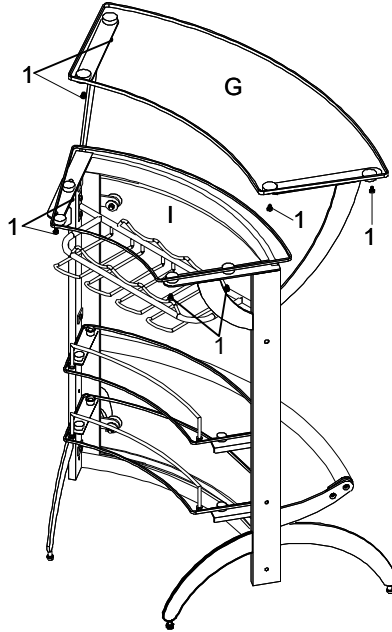

STEP 5  
COMPLETE

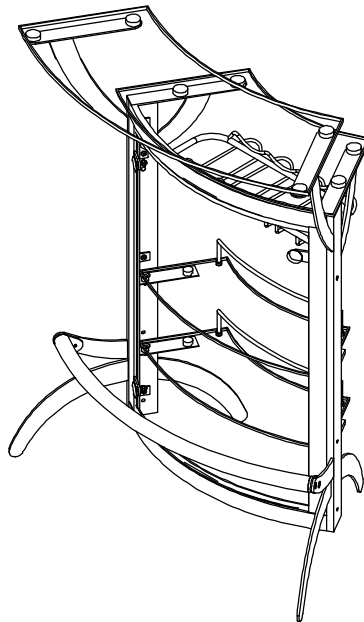

# ITEM:100135 ASSEMBLY INSTRUCTIONS



**STEP 6**      NOTE: WHEN BUYING 2 OR 3 UNITS

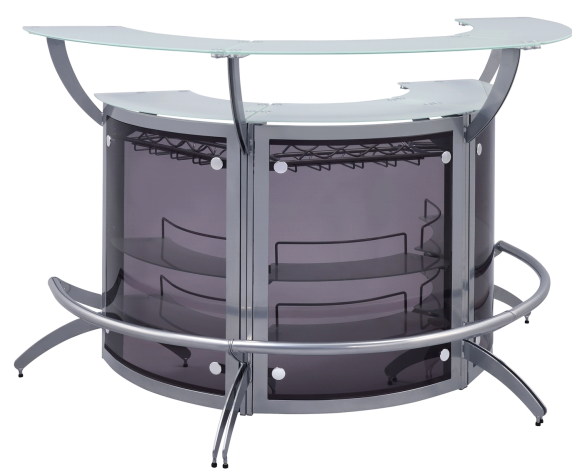
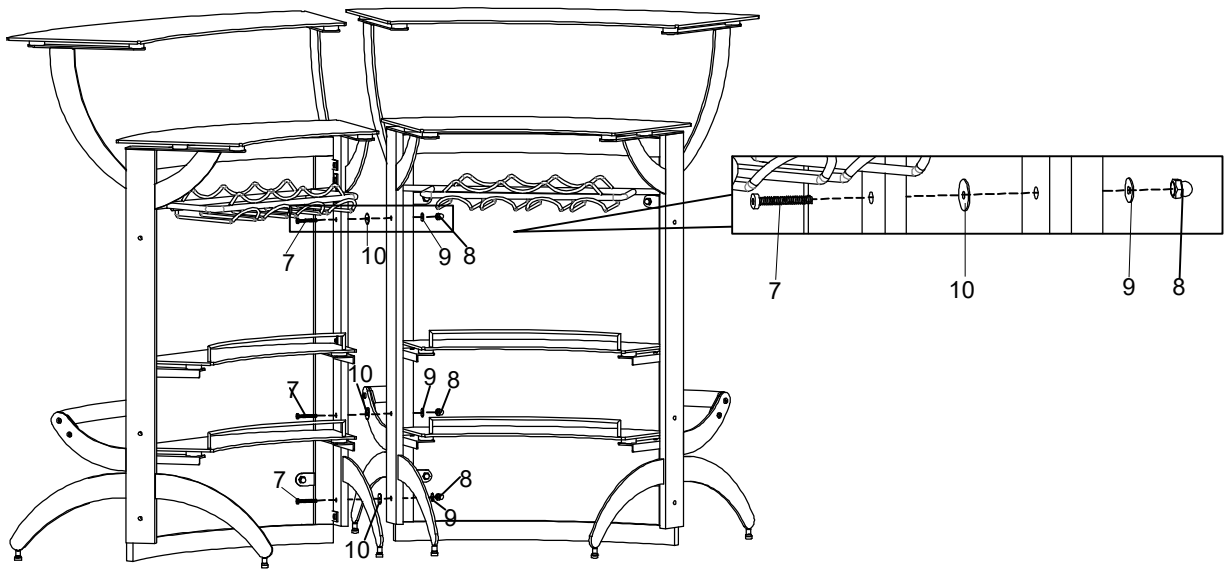

How to clean Acrylic product:  
Using a dry soft microfiber cloth, lightly brush off any dust.  
For additional care, dampen the cloth with warm water.  
For deepest cleaning, use an Acrylic cleaner.

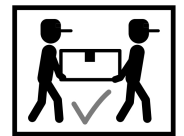

# ITEM:100135 ASSEMBLY INSTRUCTIONS



Product Size : 851 X 533 X 1050 H (MM)

Product Size : 33 1/2" X 21" X 41 1/2"

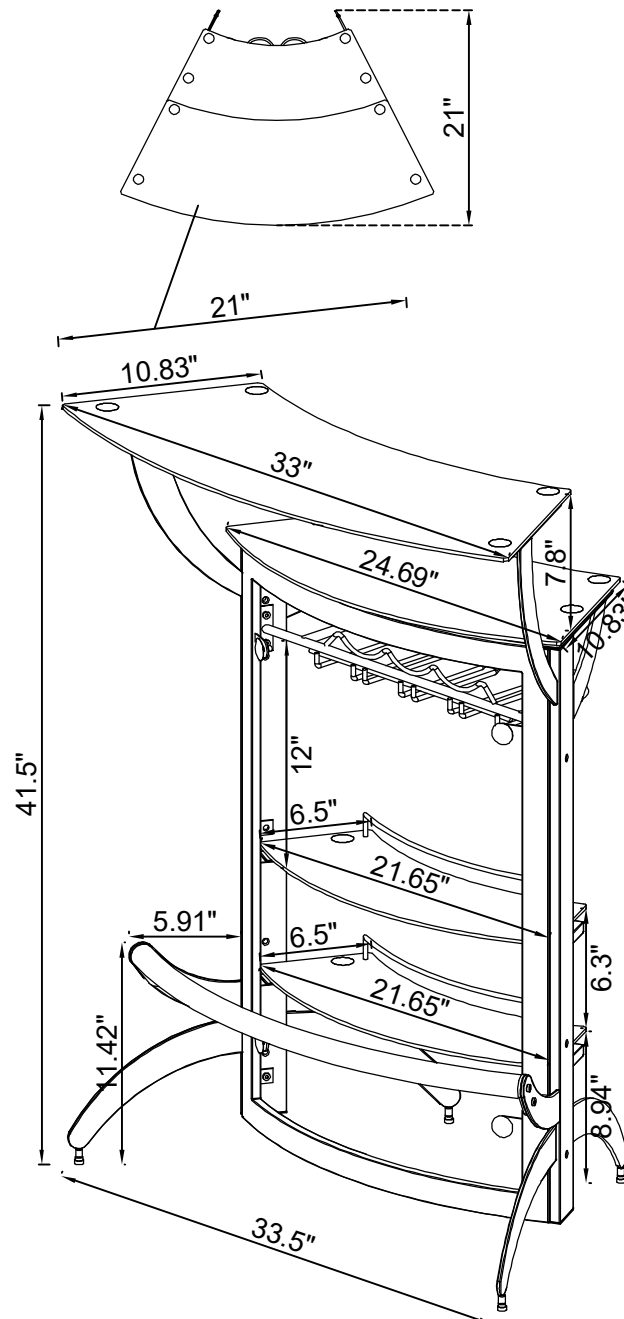

Note : Dimension tolerance  $\pm 5\%$



# ITEM:100135 ASSEMBLY INSTRUCTIONS



<b>Product Size : 1600 X 883 X 1050 H (MM)</b>
<b>Product Size : 63" X 34 <sup>3</sup>/<sub>4</sub>" X 41 <sup>1</sup>/<sub>2</sub>"</b>

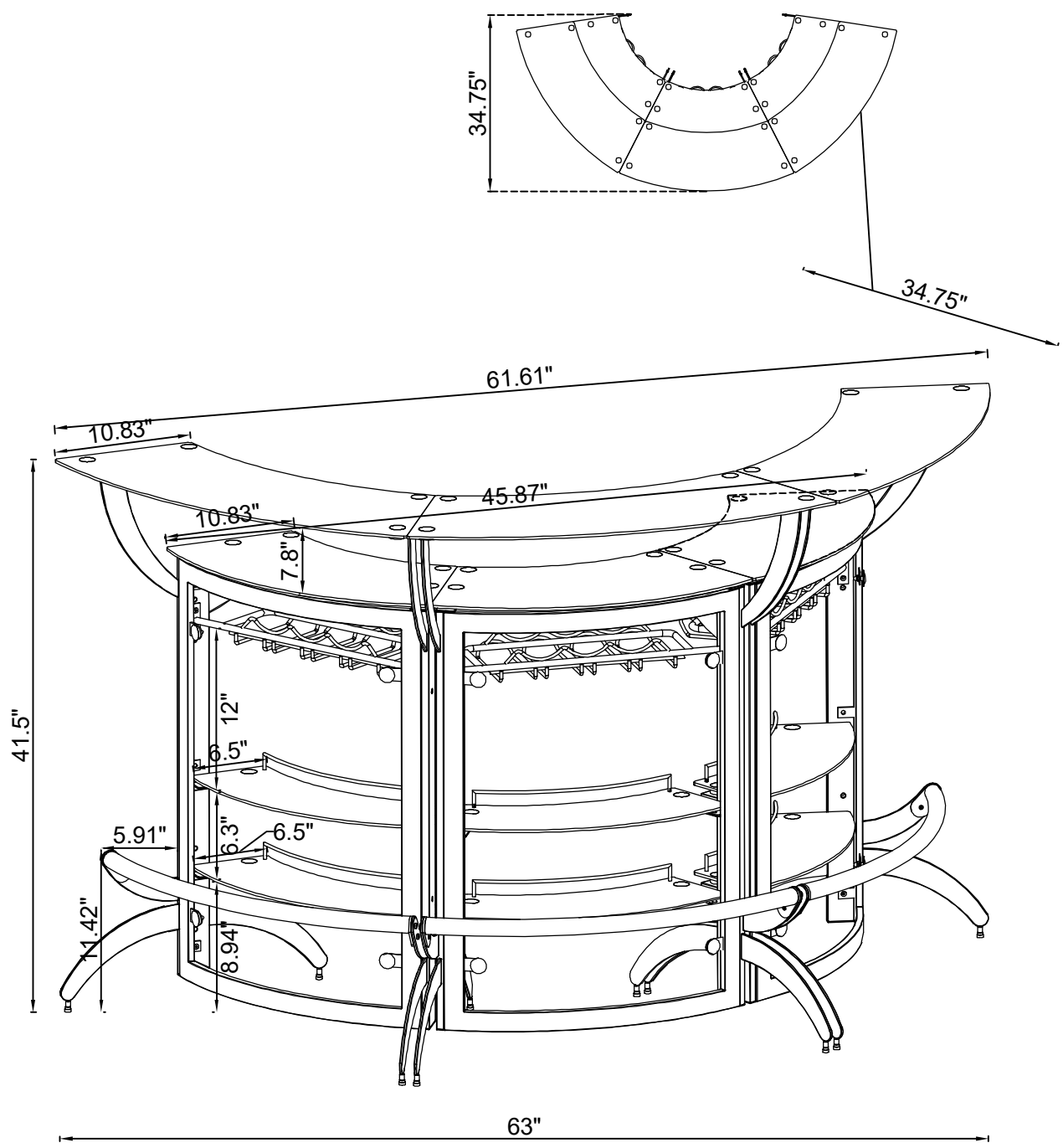

Note : Dimension tolerance  $\pm 5\%$