

ASSEMBLY INSTRUCTIONS
COASTER FINE FURNITURE



Fine Furniture for every stage of life

182135
BAR TABLE

REVISION 0 : 05/24/2019
REVISION 1 : 03/14/2023
REVISION 2 : 12/13/2024

ITEM:182135



ASSEMBLY INSTRUCTIONS

ASSEMBLY TIPS:

1. Remove hardware from box and sort by size.
2. Please check to see that all hardware and parts are present prior to start of assembly.
3. Please follow attached instructions in the same sequence as numbered to assure fast & easy assembly.



WARNING!

1. Don't attempt to repair or modify parts that are broken or defective. Please contact the store immediately.
2. This product is for home use only and not intended for commercial establishments.

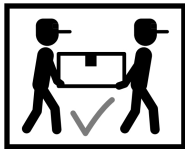

ASSEMBLY TIME 60 MINUTES

PARTS IDENTIFICATION

A LEFT LEG 1PC

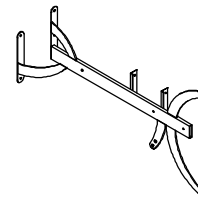

B RIGHT LEG 1PC

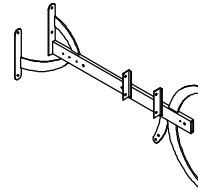

C FRONT FRAME 1PC

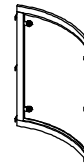

D HANGER BRACKET 1PC

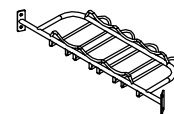

E BOTTOM SUPPORT 1PC

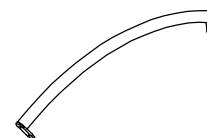

F GLASS SHELF SUPPORT 2PCS



ITEM:182135

ASSEMBLY INSTRUCTIONS

PARTS IDENTIFICATION



G UPPER TOP GLASS

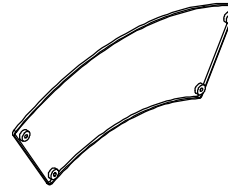

1PC

H GLASS SHELF

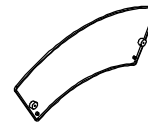

2PCS

I LOWER TOP GLASS

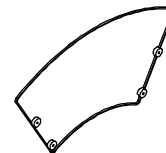

1PC

HARDWARE IDENTIFICATION

1 ALLEN BOLT-MEDIUM
(1/4" x 8mm BLK)



22PCS

2 ALLEN BOLT-SMALL
(1/4" x 9mm BLK)



4PCS

3 BOLT
(3/16" x 12mm BLK)



4PCS

4 SMALL WASHER
(ϕ 15mm)



4PCS

5 SUCTION CUP
(6mm)



4PCS

6 FLOOR LEVELER
(1/4" x 6mm BLK)



4PCS

7 ALLEN BOLT-LARGE
(1/4" x 38mm BLK)



3PCS

8 NUT
(1/4" BLK)



3PCS

9 WASHER
(ϕ 16mm BLK)



3PCS

10 PLASTIC WASHER
(ϕ 26mm)



3PCS

11 ALLEN WRENCH
(4mm)



1PC

12 HEXAGONAL WRENCH
(1/4")



1PC

NOTE: PART 7,8,9,AND 10 ARE NEEDED ONLY WHEN BUYING 2 UNITS

ITEM:182135 ASSEMBLY INSTRUCTIONS



STEP 1 Do not tighten until each step is completed or instructed.

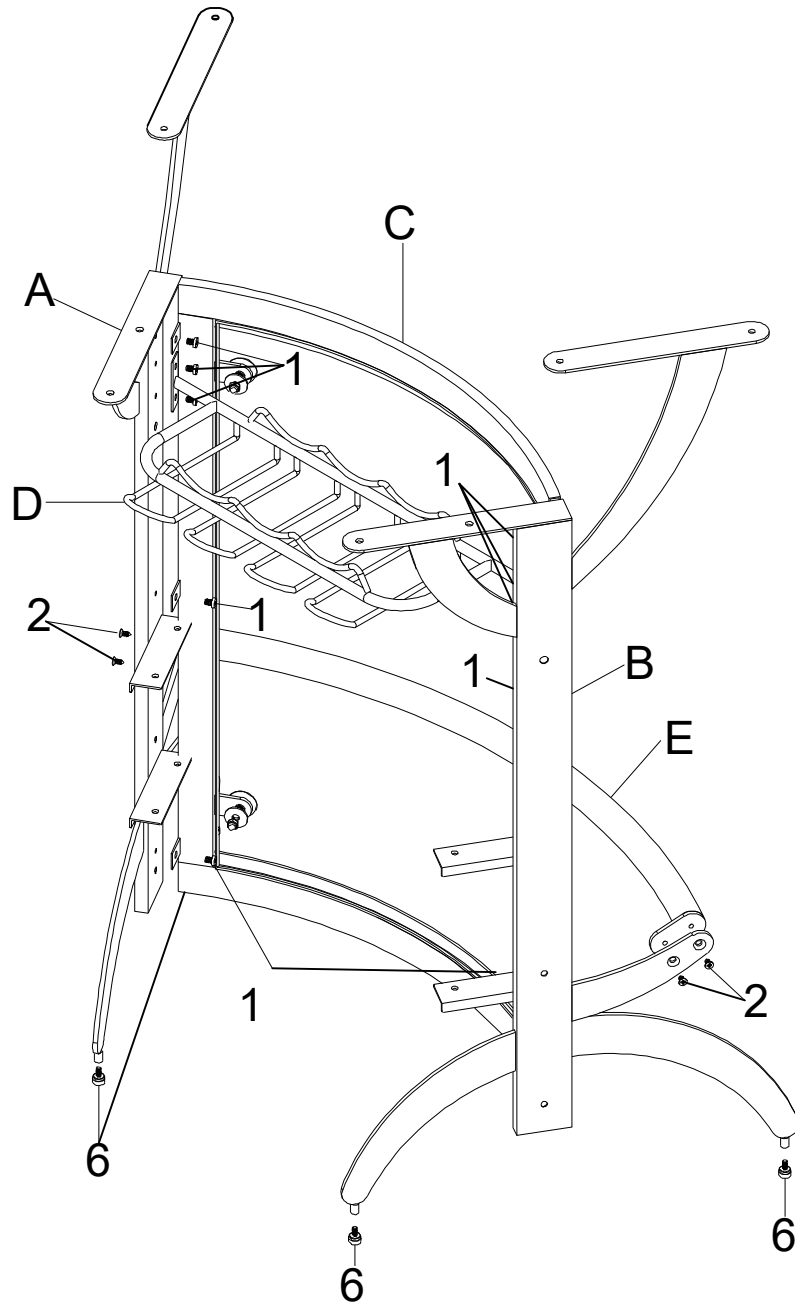

ITEM:182135
ASSEMBLY INSTRUCTIONS
STEP 2

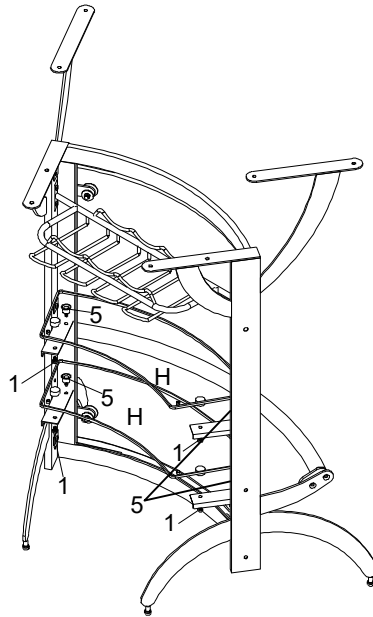

STEP 3

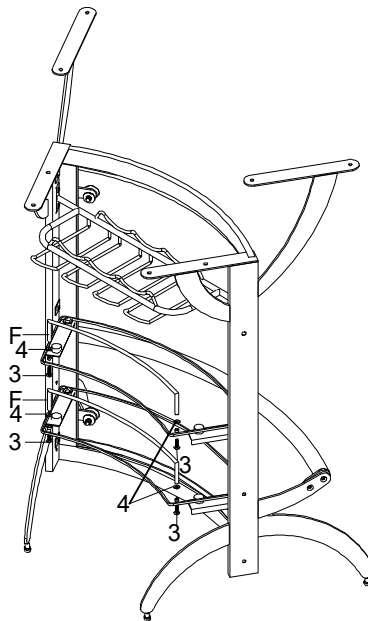

ITEM:182135
ASSEMBLY INSTRUCTIONS
STEP 4

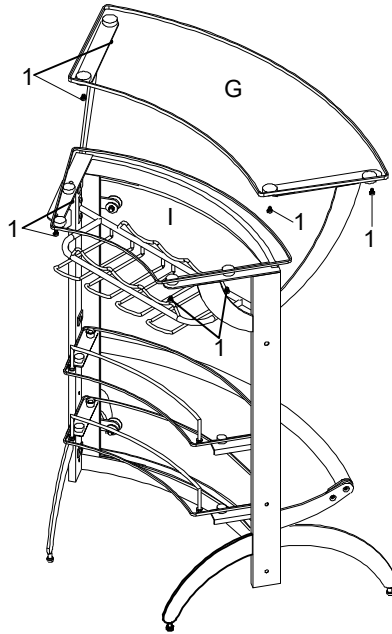

STEP 5
COMPLETE

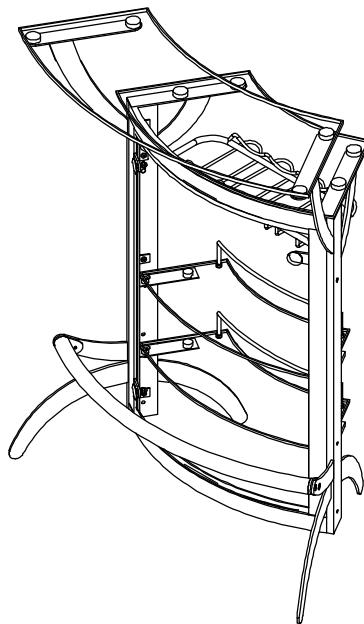

ITEM:182135 ASSEMBLY INSTRUCTIONS



STEP 6 NOTE: WHEN BUYING 2 OR 3 UNITS

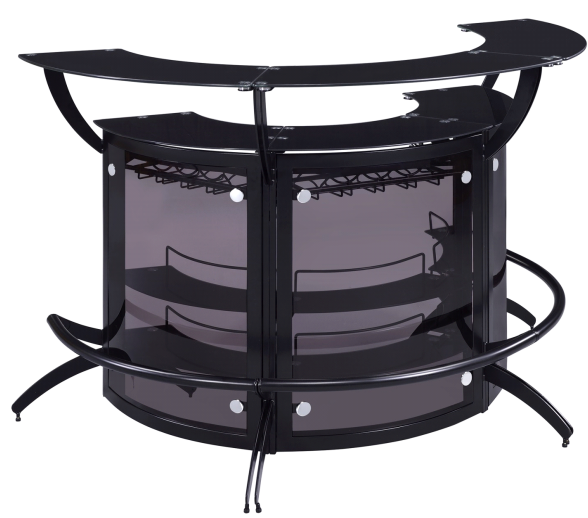
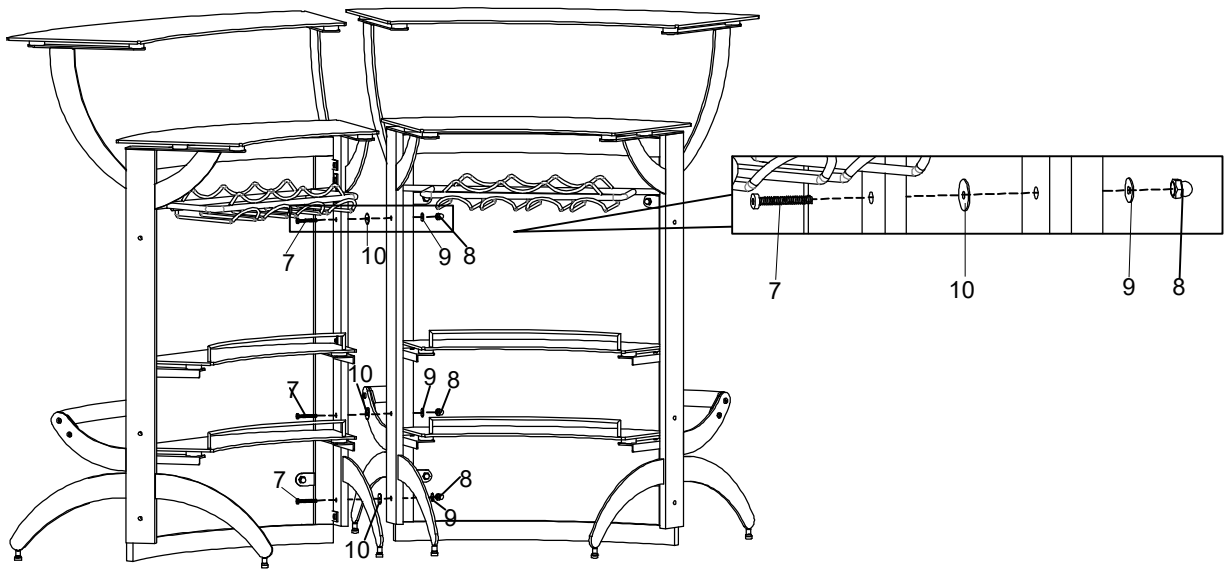

How to clean Acrylic product:
Using a dry soft microfiber cloth, lightly brush off any dust.
For additional care, dampen the cloth with warm water.
For deepest cleaning, use an Acrylic cleaner.

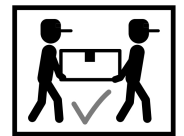

ITEM:182135 ASSEMBLY INSTRUCTIONS



Product Size : 851 X 533 X 1050 H (MM)
Product Size : 33 1/2" X 21" X 41 1/2"

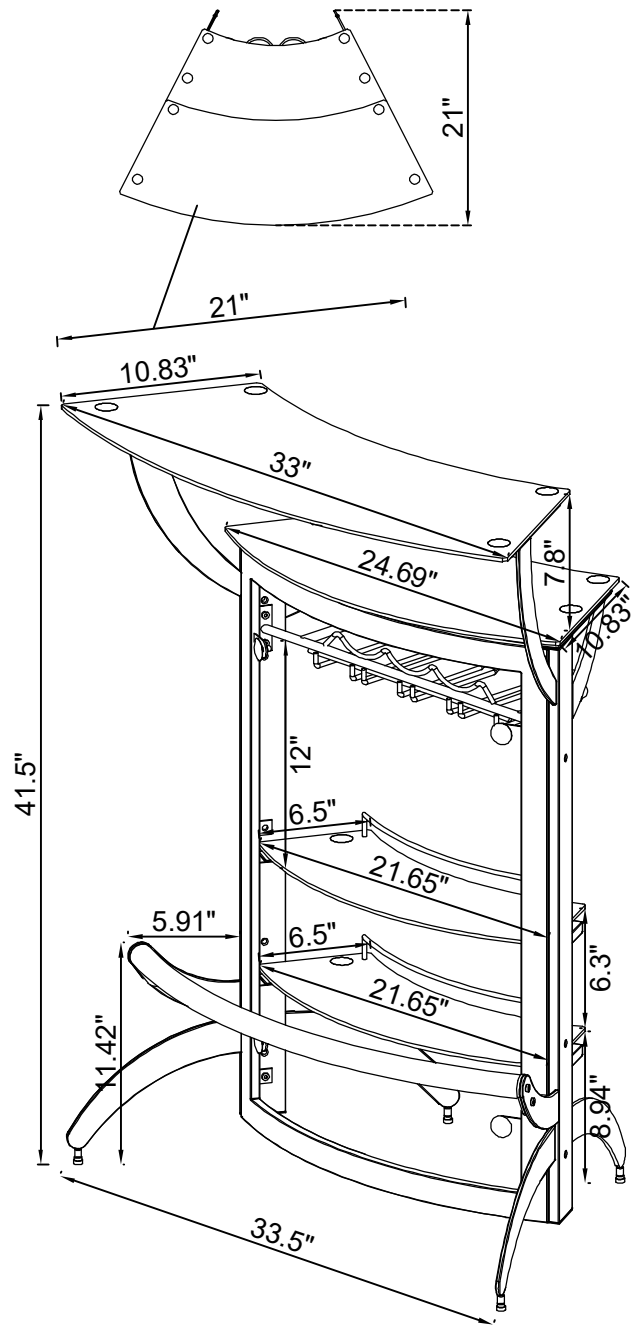

Note : Dimension tolerance $\pm 5\%$

ITEM:182135 ASSEMBLY INSTRUCTIONS



Product Size : 1600 X 883 X 1050 H (MM)
Product Size : 63" X 34 3/4" X 41 1/2"

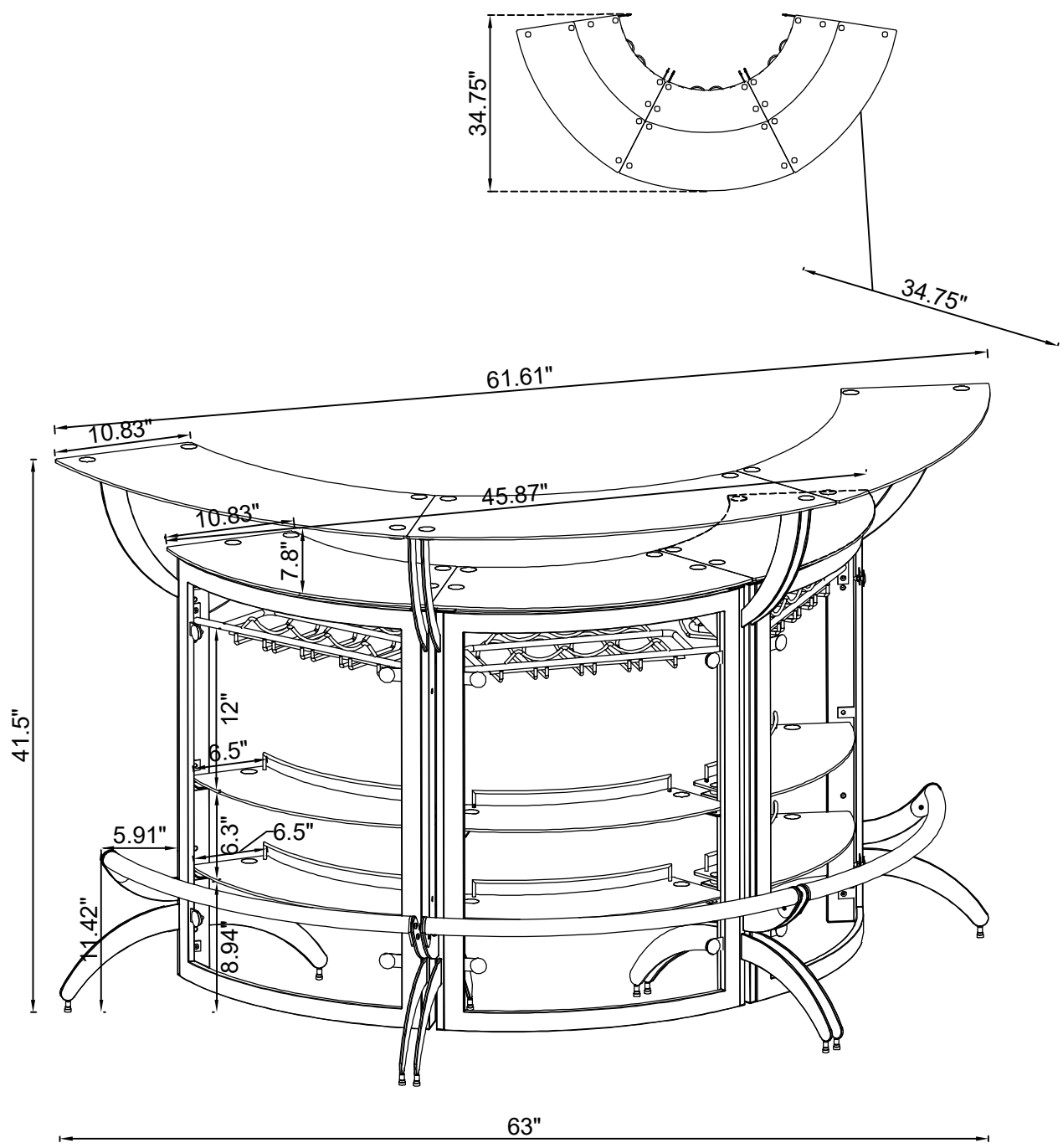

Note : Dimension tolerance $\pm 5\%$