

*ASSEMBLY INSTRUCTIONS*  
*COASTER FINE FURNITURE*



*Fine Furniture for every stage of life*

**710067**  
**END TABLE**

ITEM: 710067



# ASSEMBLY INSTRUCTIONS

## ASSEMBLY TIPS:

1. Remove hardware from box and sort by size.
2. Please check to see that all hardware and parts are present prior to start of assembly.
3. Please follow attached instructions in the same sequence as numbered to assure fast & easy assembly.



## WARNING!





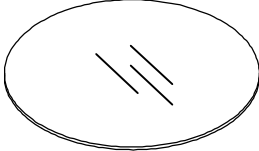
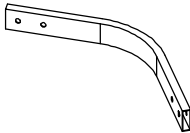
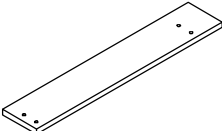

1. Don't attempt to repair or modify parts that are broken or defective. Please contact the store immediately.
2. This product is for home use only and not intended for commercial establishments.

ASSEMBLY TIME 30 MINUTES

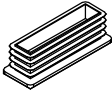
## PARTS IDENTIFICATION

A	TOP GLASS		1PC
B	CROSSBAR		6PCS
C	ACRYLIC LEG		3PCS

## Z HARDWARE IDENTIFICATION

1	BOLT (1/4" x 38mm GD)		12PCS	5	CAP (13 x 38mm GD)		12PCS
2	NUT ( $\phi$ 1/4")		12PCS	6	WASHER		12PCS
3	COVER ( $\phi$ 11mm)		12PCS	7	ALLEN WRENCH (4mm)		1PC
4	SUCTION CUP ( $\phi$ 12mm)		6PCS				

ITEM:710067



# ASSEMBLY INSTRUCTIONS

**STEP 1** Do not tighten until each step is completed or instructed.

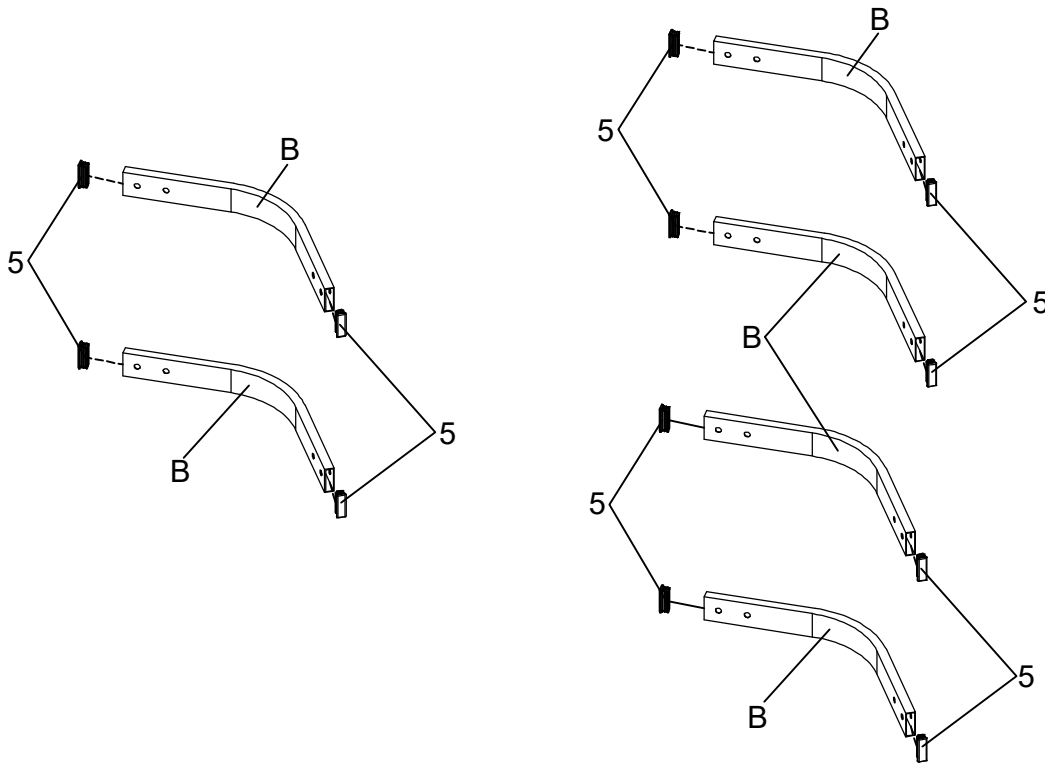

## STEP 2

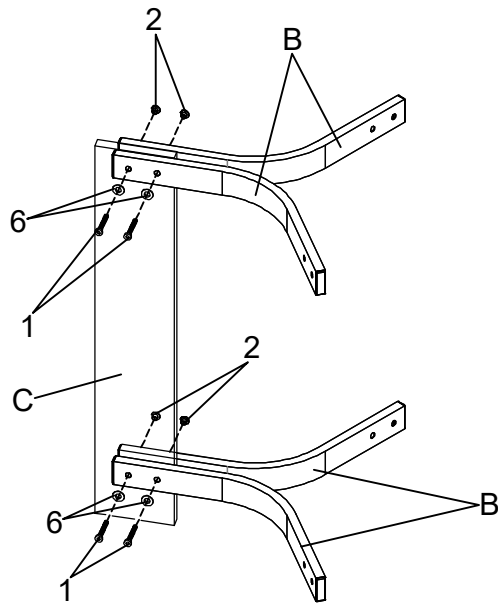

ITEM: 710067

# ASSEMBLY INSTRUCTIONS

## STEP 3

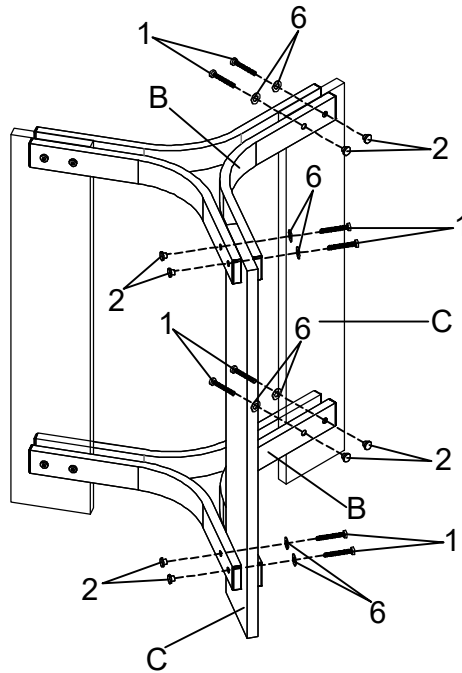

## STEP 4

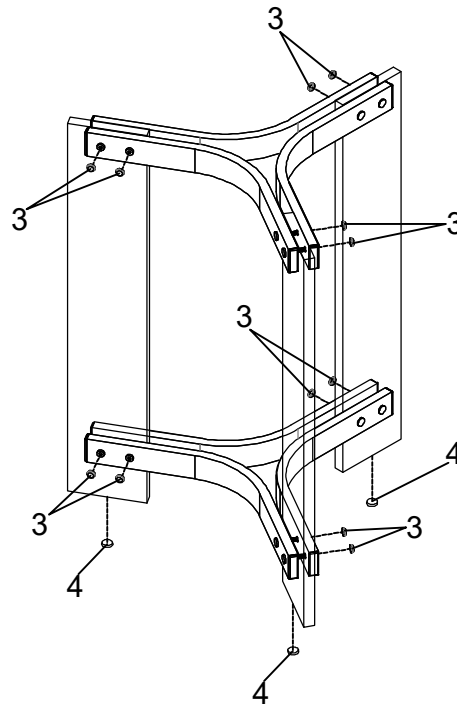

ITEM: 710067

# ASSEMBLY INSTRUCTIONS

## STEP 5

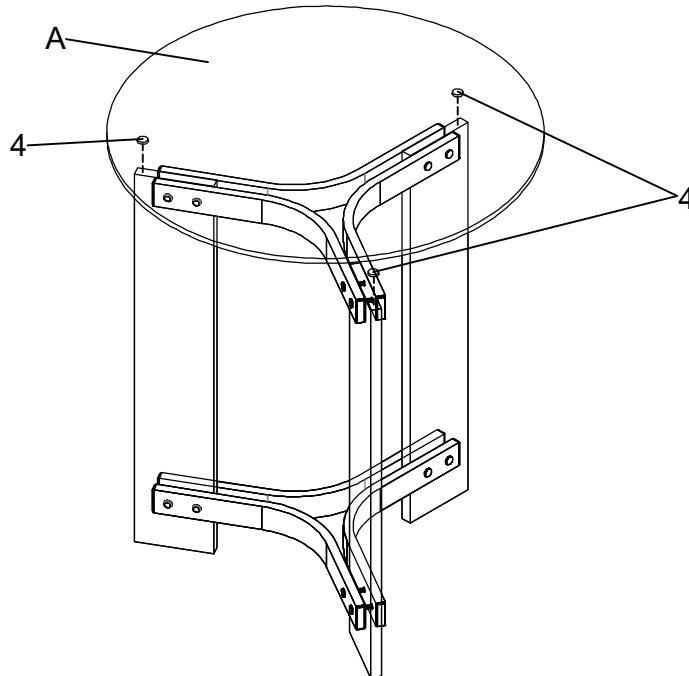

## STEP 6 COMPLETE

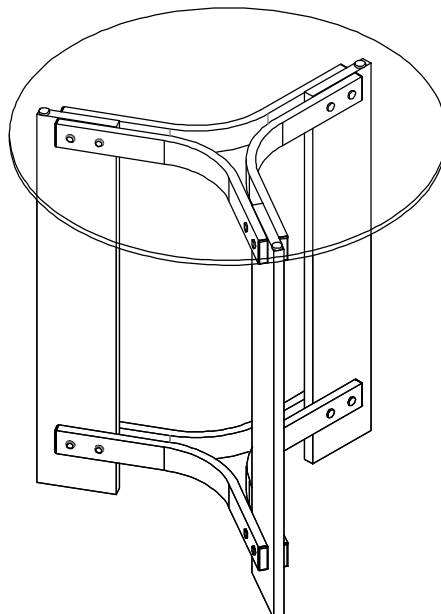

How to clean Acrylic product:  
Using a dry soft microfiber cloth, lightly brush off any dust.  
For additional care, dampen the cloth with warm water.  
For deepest cleaning, use an Acrylic cleaner.

# ITEM:710067

## ASSEMBLY INSTRUCTIONS



**Product Size : 600 DIA X 610 H (MM)**

**Product Size : 23.5" DIA X 24" H**

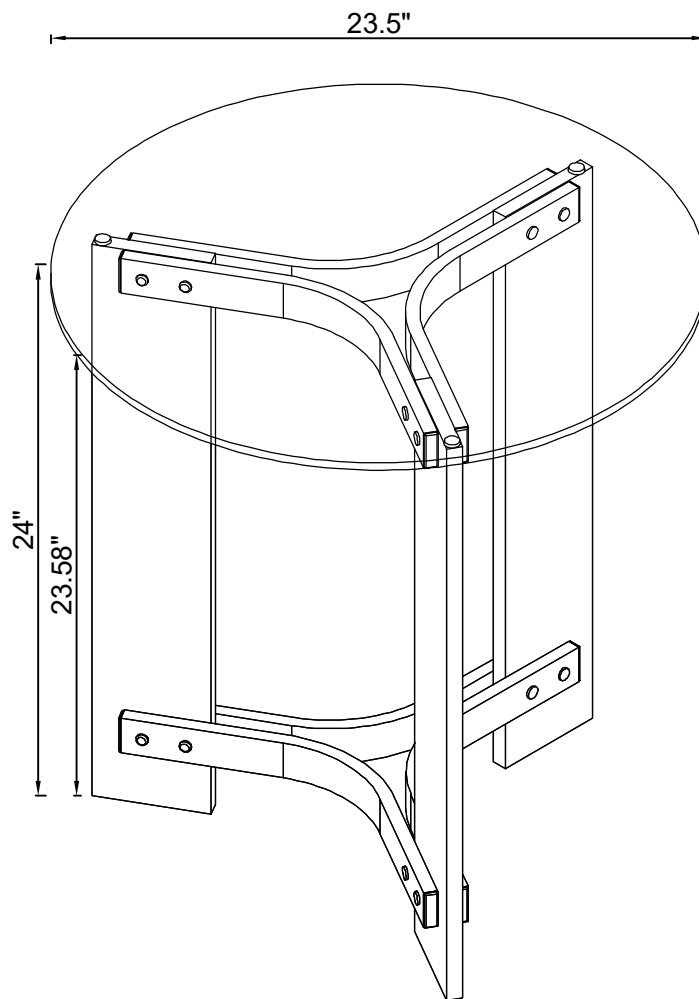

Note : Dimension tolerance  $\pm 5\%$