



ASSEMBLY INSTRUCTIONS
COASTER FINE FURNITURE



Fine Furniture for every stage of life

106629
Counter Chair

ITEM: **106629**



ASSEMBLY INSTRUCTIONS

ASSEMBLY TIPS:

1. Remove hardware from box and sort by size.
2. Please check to see that all hardware and parts are present prior to start of assembly.
3. Please follow attached instructions in the same sequence as numbered to assure fast & easy assembly.



WARNING!







1. Don't attempt to repair or modify parts that are broken or defective. Please contact the store immediately.
2. This product is for home use only and not intended for commercial establishments.









ASSEMBLY TIME

15 MINUTES

PARTS IDENTIFICATION

A	BACK FRAME		1PC	E	LEFT FRONT LEG		1PC
B	SEAT CUSHION WITH FRAME		1PC	F	RIGHT FRONT LEG		1PC
C	LEFT SIDE STRETCHER		1PC	G	FRONT STRETCHER		1PC
D	RIGHT SIDE STRETCHER		1PC				

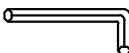
HARDWARE IDENTIFICATION

1	LONG BOLT (Ø1/4" x 3" - RBW)		4PCS	5	FLAT WASHER (Ø5/16" - RBW)		9PCS
2	MEDIUM BOLT (Ø1/4" x 2-3/8" - RBW)		4PCS	6	FLAT HEAD SCREW (Ø4 x 40mm - RBW)		6PCS
3	SHORT BOLT (Ø1/4" x 1-3/8" - RBW)		1PC	7	ALLEN WRENCH (M4 x 59mm - RBW)		1PC
4	LOCK WASHER (Ø5/16" - RBW)		9PCS				

NOTE:

Quantities shown are for one chair.

Phillips head screw driver is required in the assembly process; however, manufacturer does not provide this item.

ITEM: **106629**



ASSEMBLY INSTRUCTIONS

STEP 1

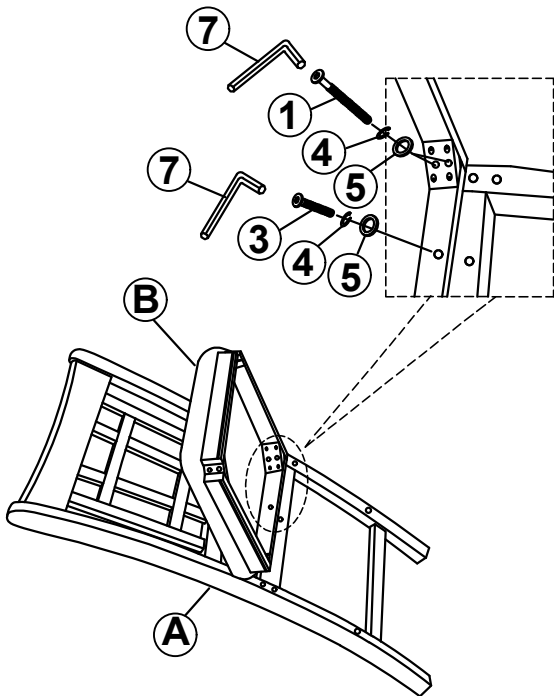

STEP 2

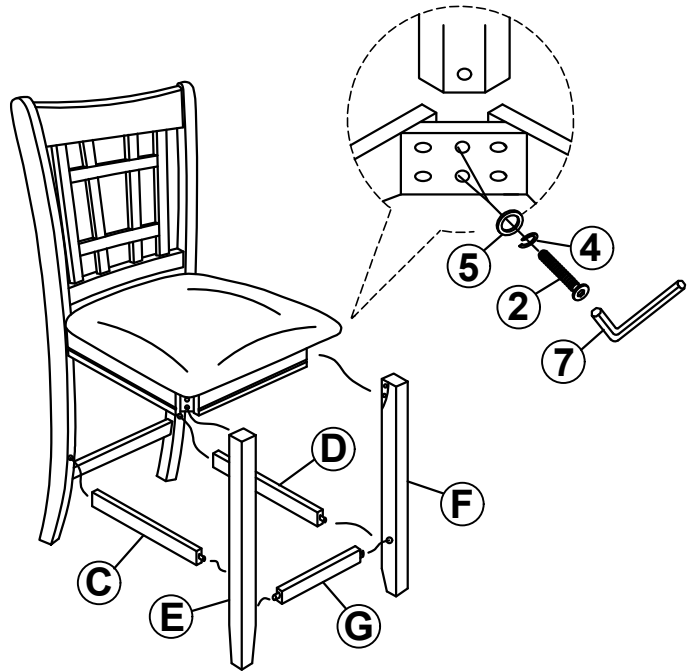

STEP 3

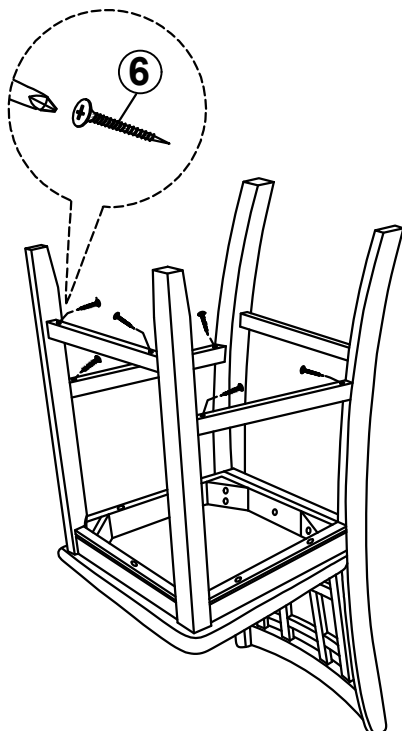

STEP 4 **COMPLETE**

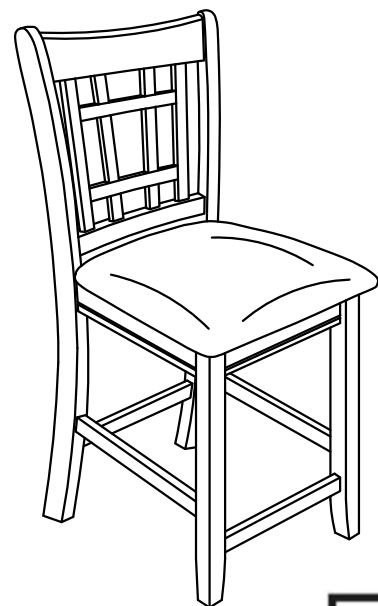

ITEM: 106629

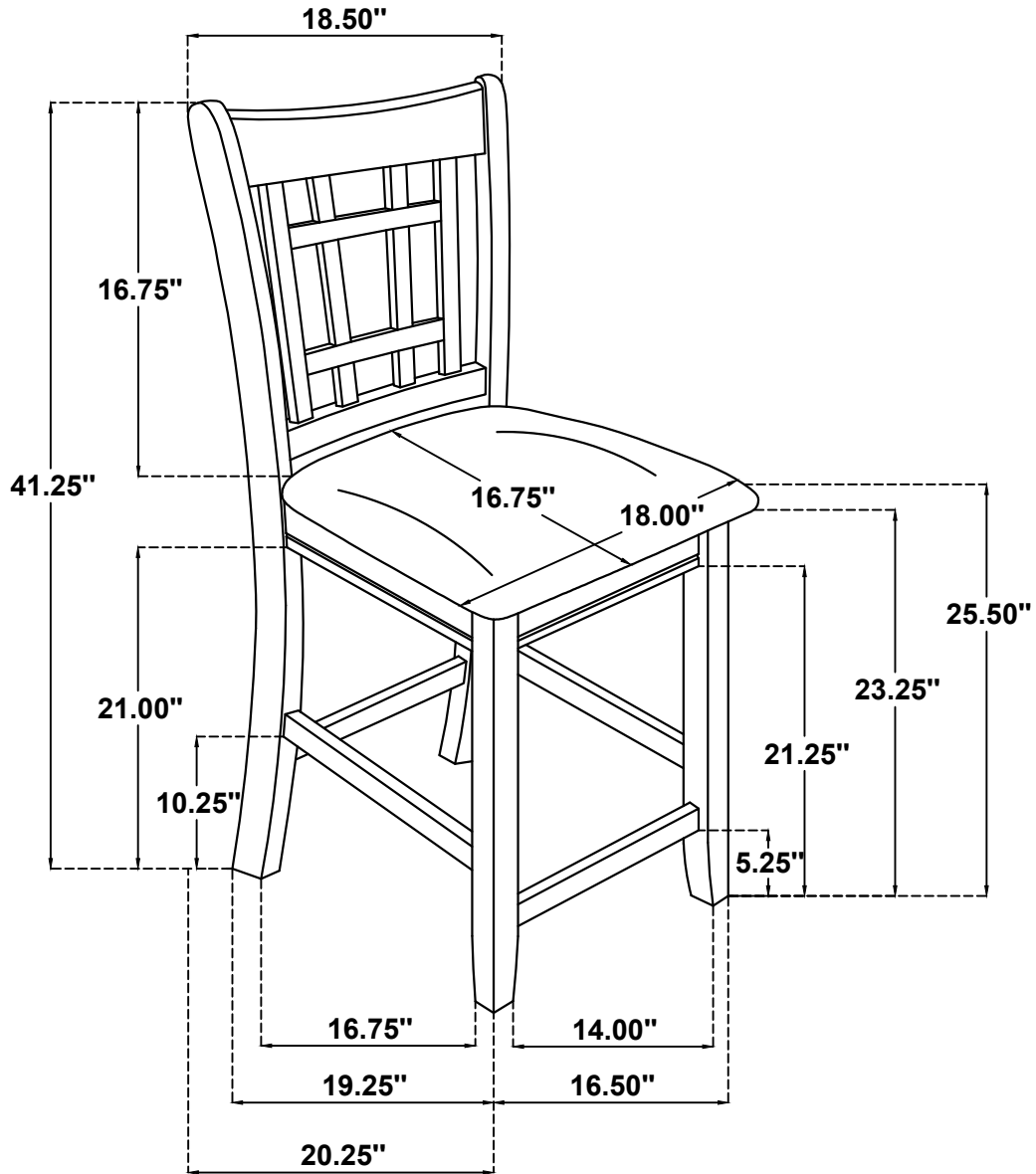

Note: Dimension tolerance $\pm 5\%$