

ASSEMBLY INSTRUCTIONS
COASTER FINE FURNITURE



Fine Furniture for every stage of life

121233
Arm Chair

ITEM:121233



ASSEMBLY INSTRUCTIONS

ASSEMBLY TIPS:

1. Remove hardware from box and sort by size.
2. Please check to see that all hardware and parts are present prior to start of assembly.
3. Please follow attached instructions in the same sequence as numbered to assure fast & easy assembly.



WARNING!



1. Don't attempt to repair or modify parts that are broken or defective. Please contact the store immediately.
2. This product is for home use only and not intended for commercial establishments.





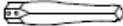

ASSEMBLY TIME

15 MINUTES

PARTS IDENTIFICATION

A	SEAT AND BACK		1PC
B	LEFT BACK LEG		1PC
C	RIGHT BACK LEG		1PC
D	FRONT LEG		2PCS

HARDWARE IDENTIFICATION

1	BOLT (1/4 x 13 x 63mm - BLK)		8PCS
2	LOCK WASHER (1/4 x 10 x 1.1mm - BLK)		8PCS
3	FLAT WASHER (1/4 x 2 x 22mm - BLK)		8PCS
4	ALLEN WRENCH (4 x 60mm - BLK)		1PC

NOTE:

Quantities shown are for one chair.

Phillips head screw driver is required in the assembly process; however, manufacturer does not provide this item.

ITEM: **121233**

ASSEMBLY INSTRUCTIONS



STEP 1

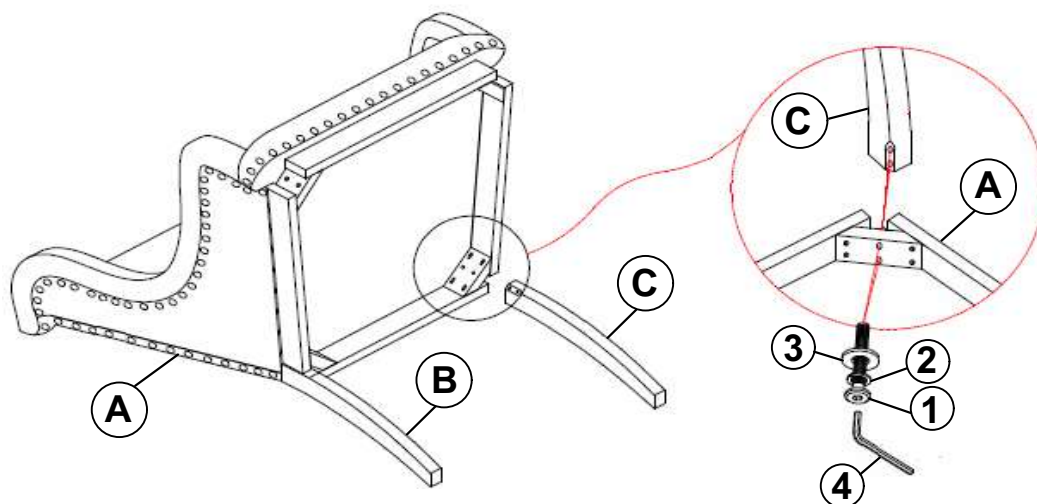

STEP 2

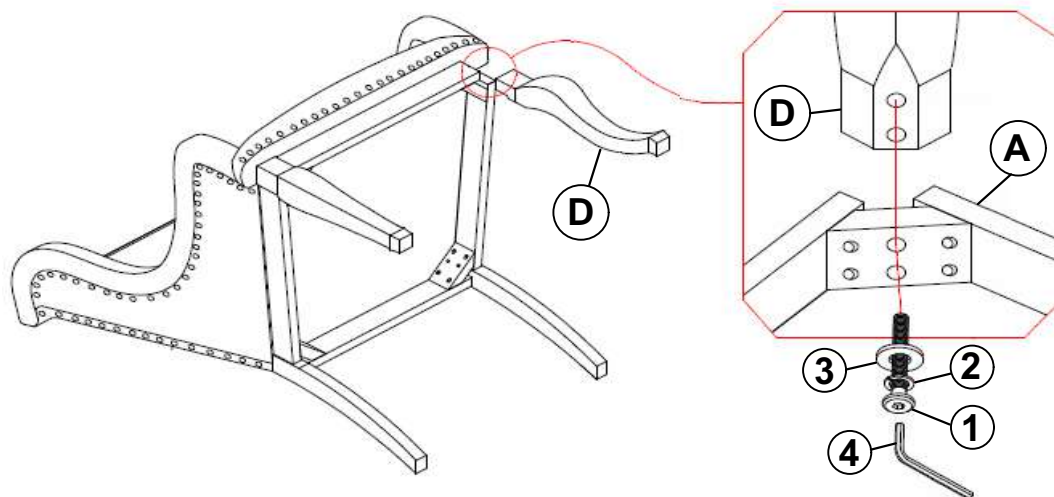

STEP 3
COMPLETE



ITEM: 121233

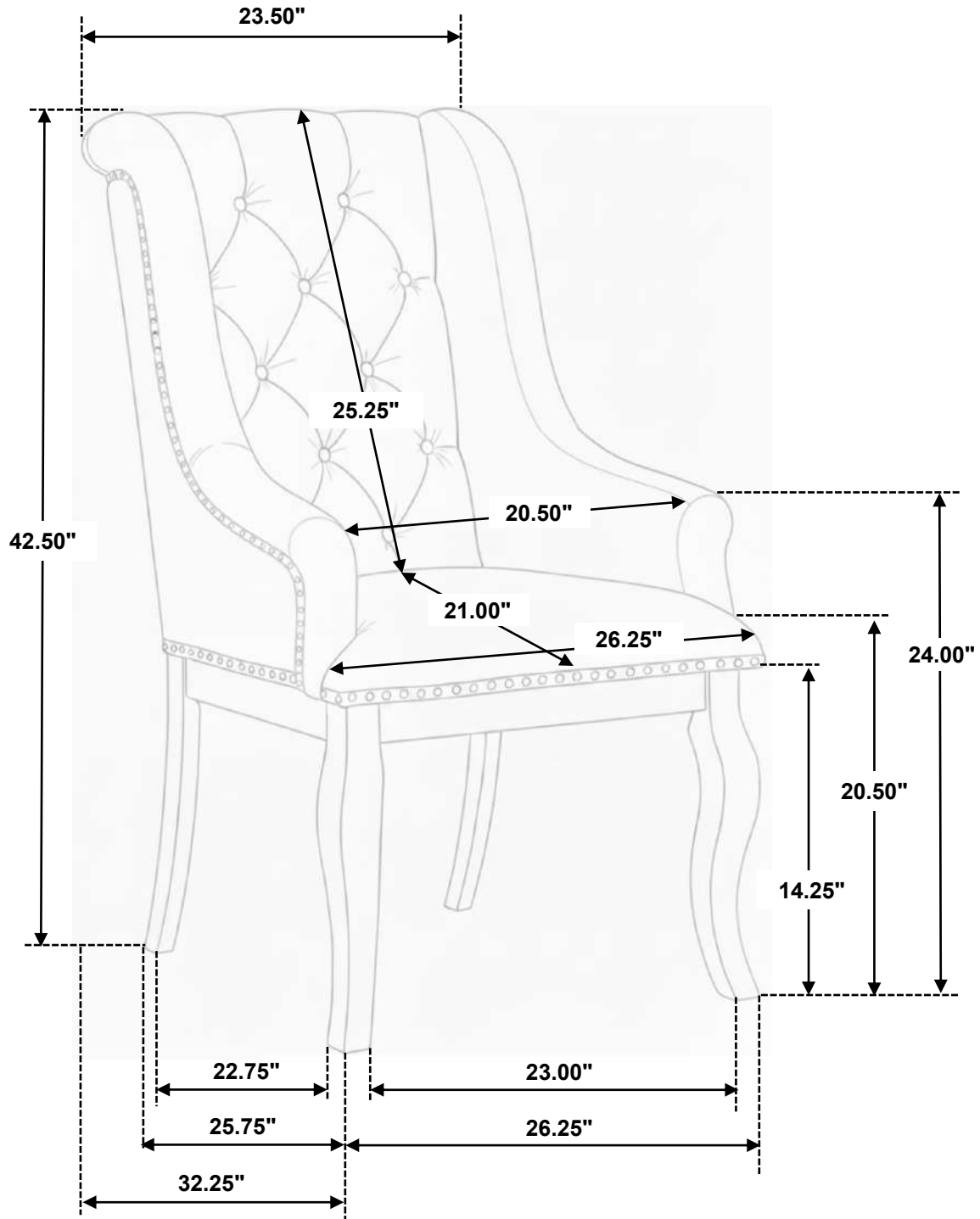

Note: Dimension tolerance $\pm 5\%$