



ASSEMBLY INSTRUCTIONS COASTER FINE FURNITURE



Fine Furniture for every stage of life

182692
Arm Chair

REVISION 0 : 03/19/2024
REVISION 1 : 09/16/2025
REVISION 2 : 12/12/2025

PAGE 1 OF 5

COASTERFURNITURE.COM

ITEM: **182692**



ASSEMBLY INSTRUCTIONS

ASSEMBLY TIPS:

1. Remove hardware from box and sort by size.
2. Please check to see that all hardware and parts are present prior to start of assembly.
3. Please follow attached instructions in the same sequence as numbered to assure fast & easy assembly.



WARNING!

1. Don't attempt to repair or modify parts that are broken or defective. Please contact the store immediately.
2. This product is for home use only and not intended for commercial establishments.



ASSEMBLY TIME

15 MINUTES

PARTS IDENTIFICATION

AV SEAT CUSHION



1PC

DV BACKREST

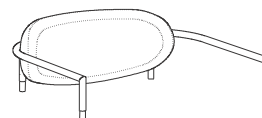

1PC

BV LEFT LEG FRAME
WITH LABEL "BV"

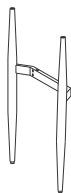

1PC

EV RIGHT LEG FRAME
WITH LABEL "EV"

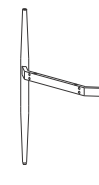

1PC

CV BACK RAIL
WITH LABEL "CV"



1PC

FV FRONT RAIL
WITH LABEL "FV"



1PC

HARDWARE IDENTIFICATION

1 LONG BOLT
(1/4" x 50mm - BLK)

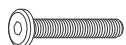

4PCS

4 LOCK WASHER
(Ø1/4" - BLK)



4PCS

2 SHORT BOLT
(1/4" x 30mm - BLK)



8PCS

5 FLAT WASHER
(Ø1/4" - BLK)



4PCS

3 PAN HEAD SCREW
(5/32" x 9 mm - BLK)



4PCS

6 ALLEN WRENCH
(4mm - BLK)



1PC

NOTE:

Quantities shown are for one chair.

Phillips head screw driver is required in the assembly process; however, manufacturer does not provide this item.

ITEM: **182692**

ASSEMBLY INSTRUCTIONS

STEP 1

Do not fully tighten all bolts until assembly is complete.

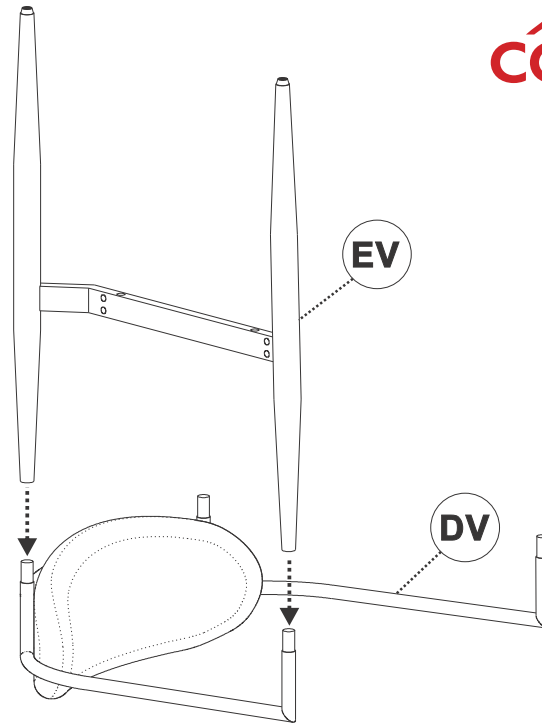

STEP 2

Note the viewing direction of detail **CV** and **FV**

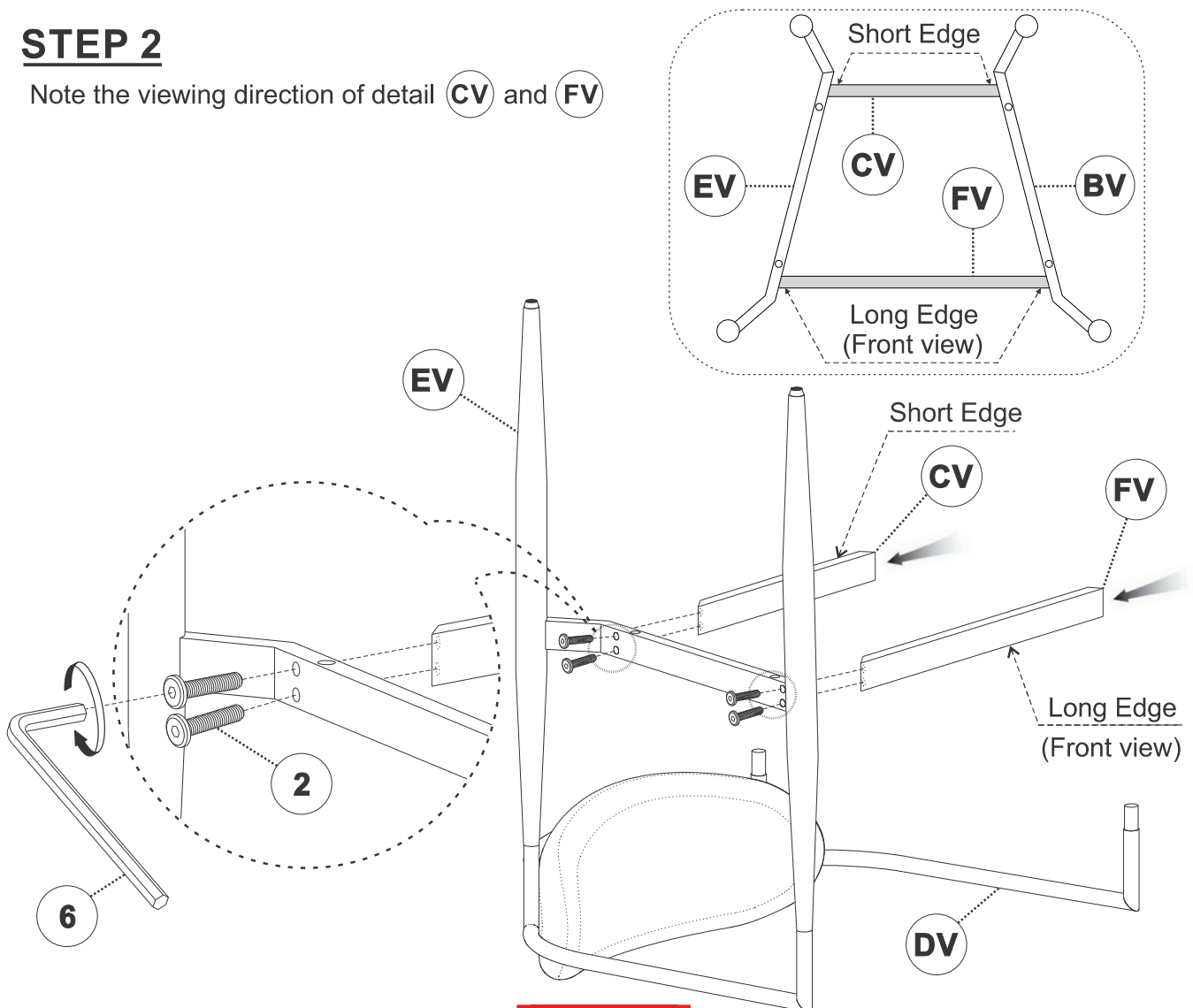

ITEM: **182692**

ASSEMBLY INSTRUCTIONS

STEP 3

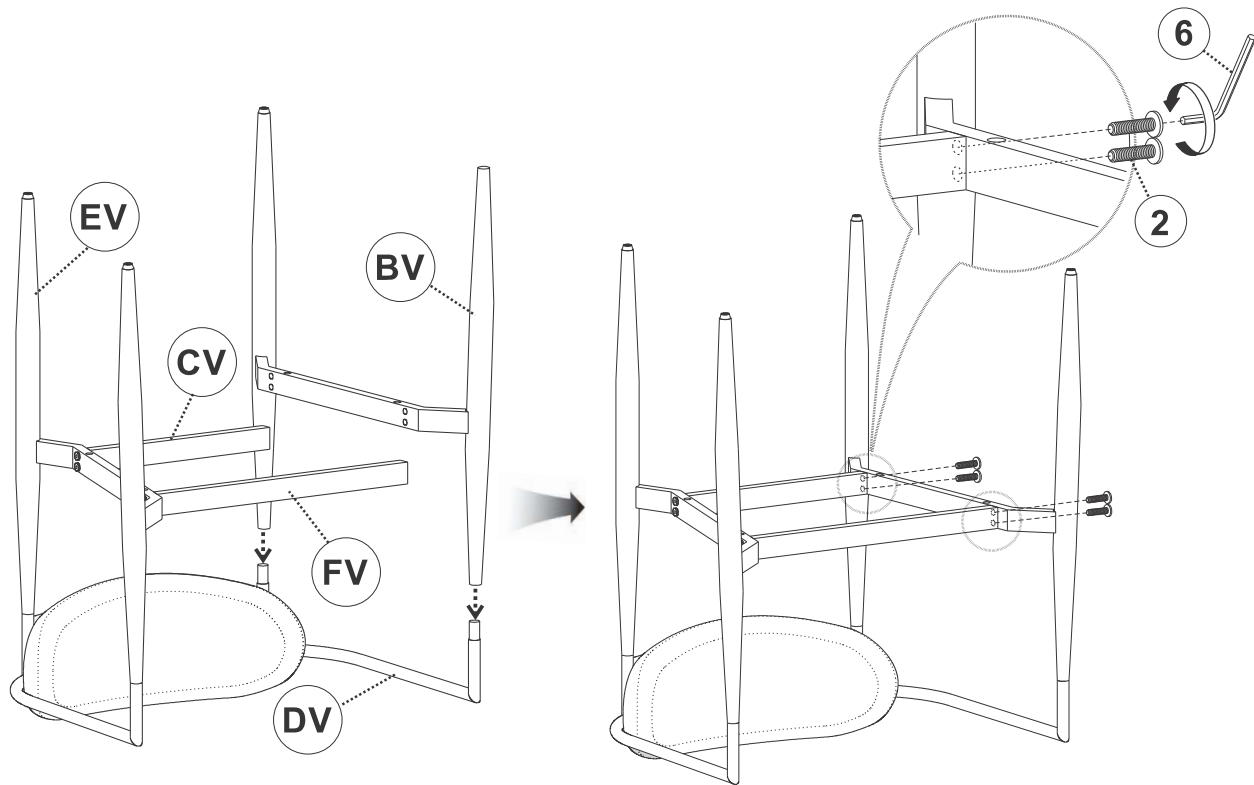

STEP 4

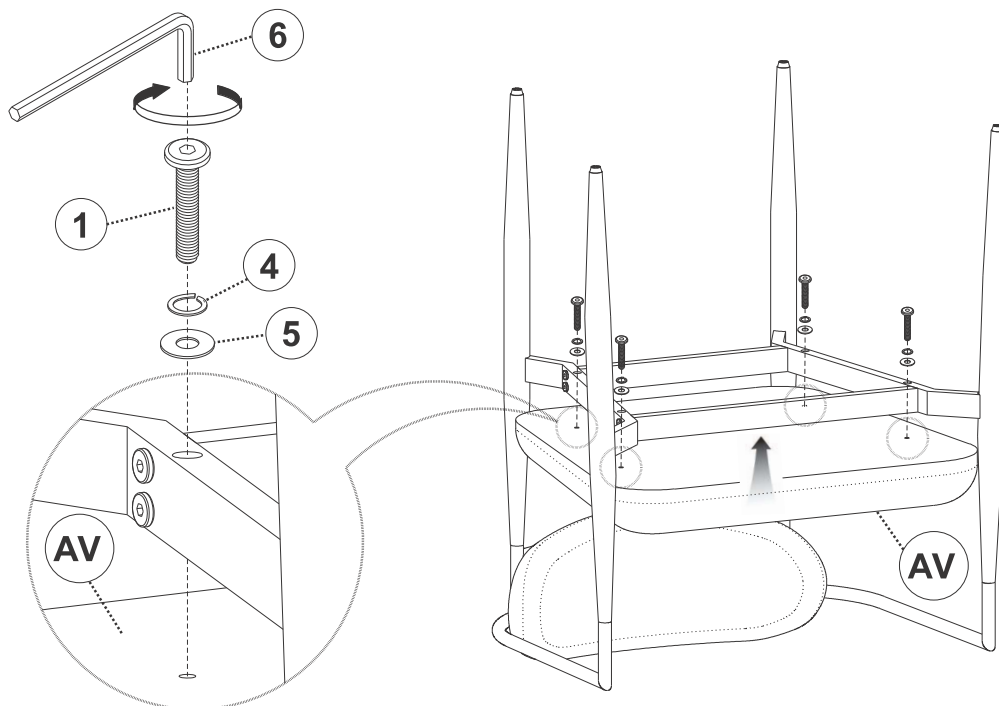

ITEM: **182692**

ASSEMBLY INSTRUCTIONS

STEP 5

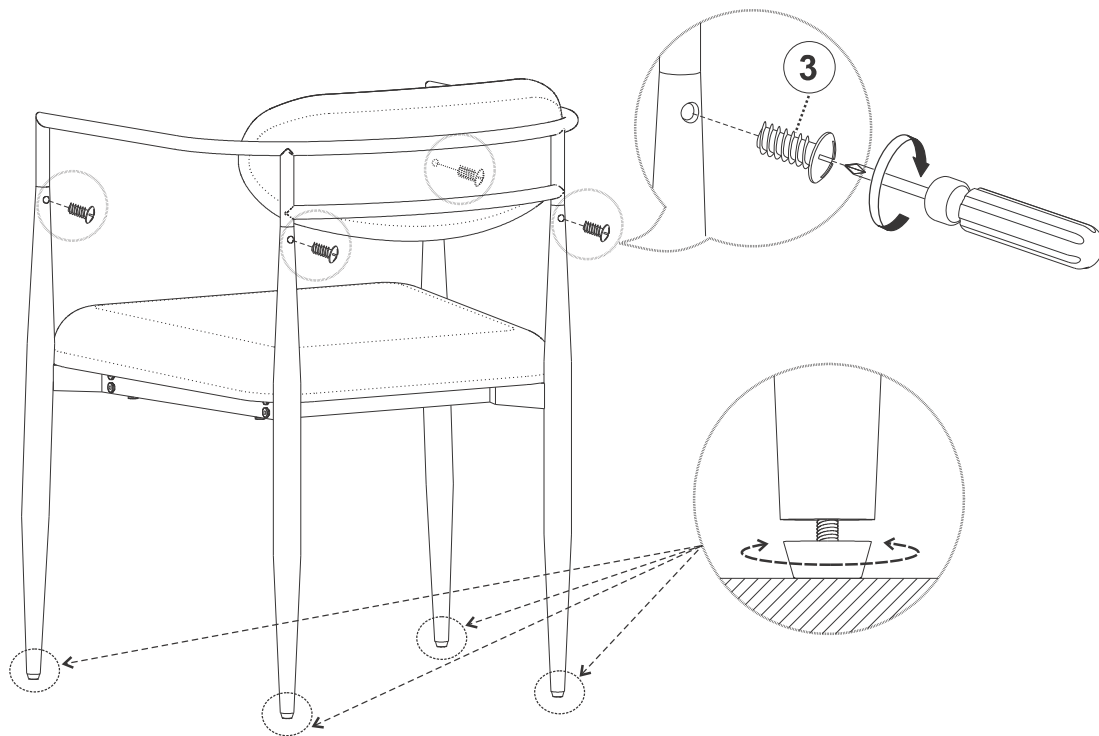

* BACK VIEW

STEP 6
COMPLETE

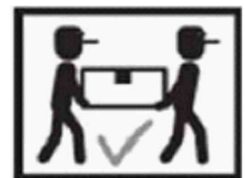
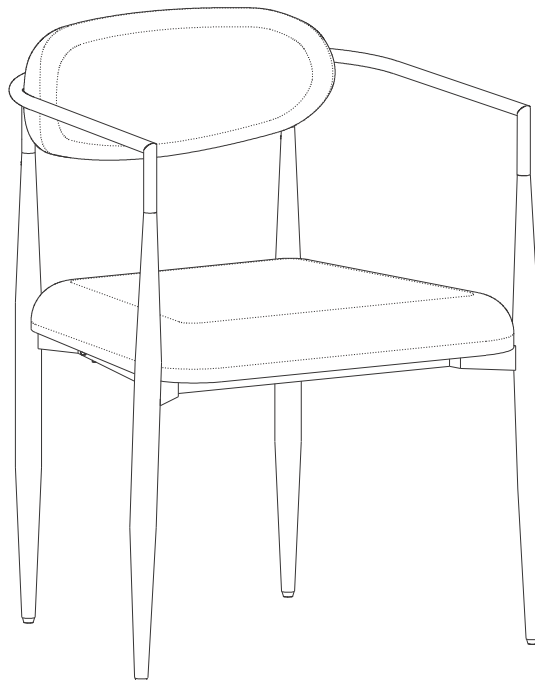

ITEM: **182692**

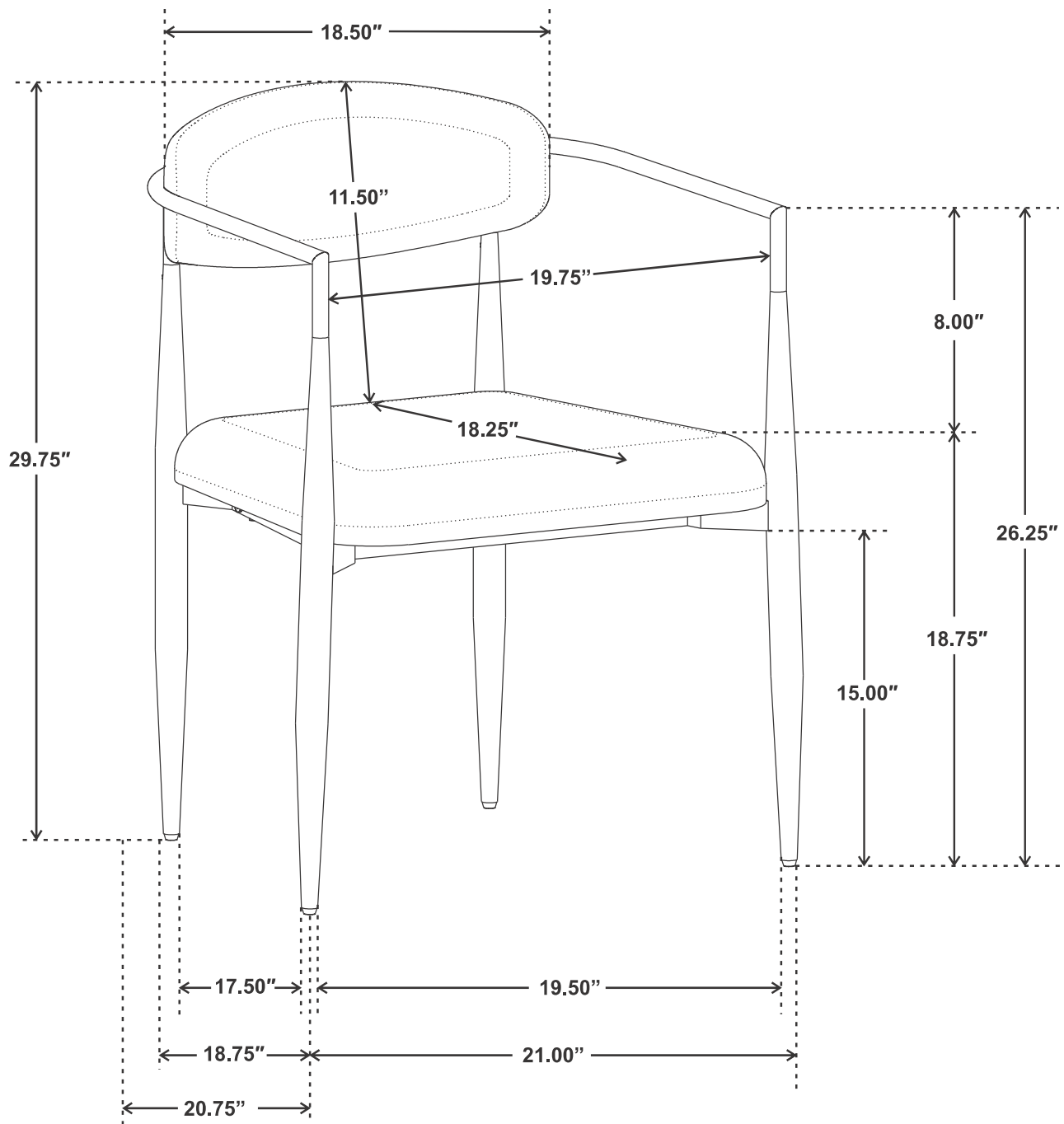

Note: Dimension tolerance $\pm 5\%$