

*ASSEMBLY INSTRUCTIONS*  
*COASTER FINE FURNITURE*



*Fine Furniture for every stage of life*

**735998**  
**Coffee Table**

ITEM: **735998**

## ASSEMBLY INSTRUCTIONS

### ASSEMBLY TIPS:

1. Remove hardware from box and sort by size.
2. Please check to see that all hardware and parts are present prior to start of assembly.
3. Please follow attached instructions in the same sequence as numbered to assure fast & easy assembly.



### WARNING!



1. Don't attempt to repair or modify parts that are broken or defective. Please contact the store immediately.
2. This product is for home use only and not intended for commercial establishments.





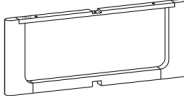
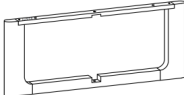

ASSEMBLY TIME

15 MINUTES

## PARTS IDENTIFICATION

A	TOP		1PC
B	UPPER LEG FRAME		1PC
C	LOWER LEG FRAME		1PC
D	BOTTOM RAIL (PRE-ATTACHED TO LOWER LEG FRAME)		1PC

## HARDWARE IDENTIFICATION

1	ALLEN WRENCH (M4 x 100mm - BLK)		1PC
2	BOLT (M6 x 35mm - RBW)		6PCS
3	LOCK WASHER (M6 - RBW)		6PCS
4	FLAT WASHER (M6 - RBW)		5PCS
5	LEVELER (M6 x 23mm)		4PCS

ITEM: **735998**

**ASSEMBLY INSTRUCTIONS**

**STEP 1**

Attention! Please remove part D from Lower Leg Frame (C), using ALLEN WRENCH (1) and keep for STEP 3.

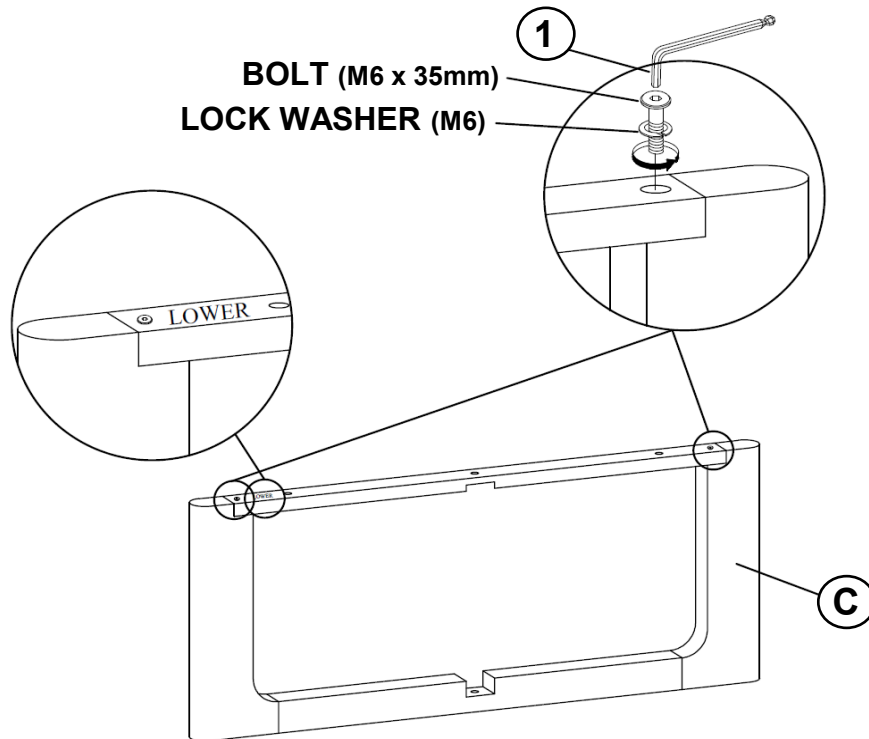

**STEP 2**

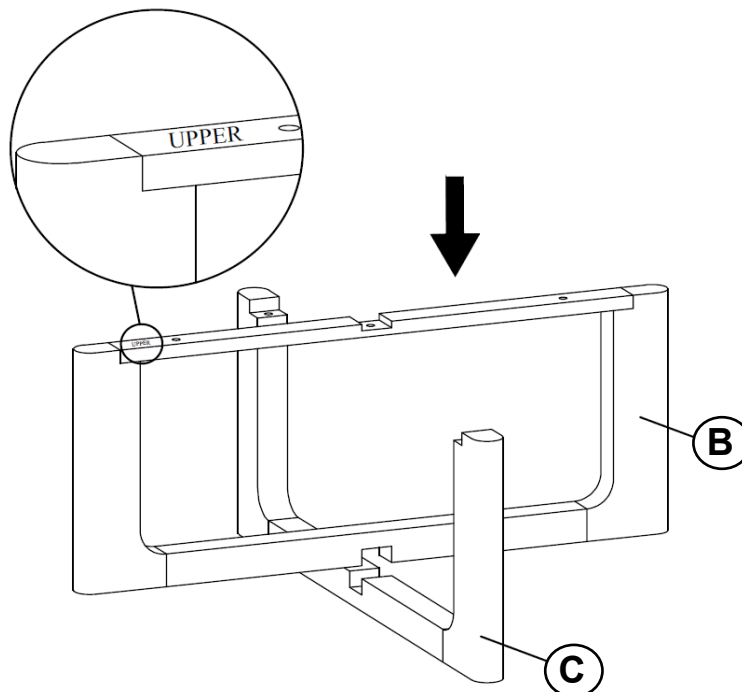

ITEM: **735998**

**ASSEMBLY INSTRUCTIONS**

**STEP 3**

Attention! Use hardware from **STEP 1** for this **STEP**.

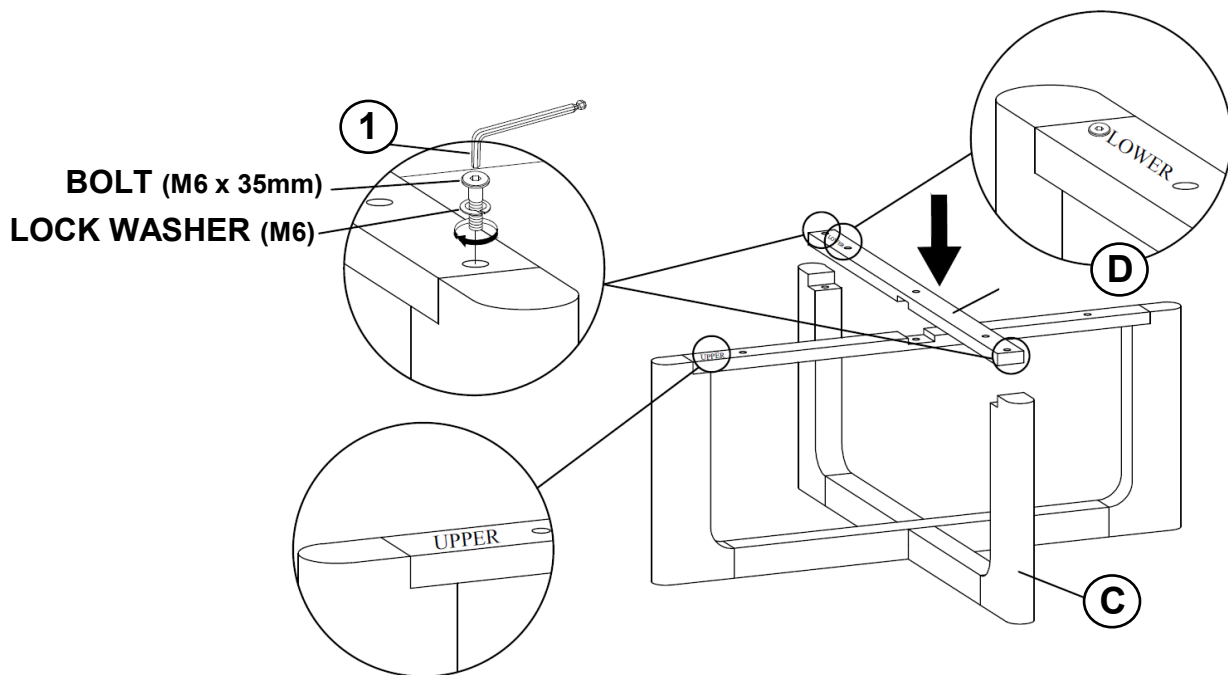

**STEP 4**

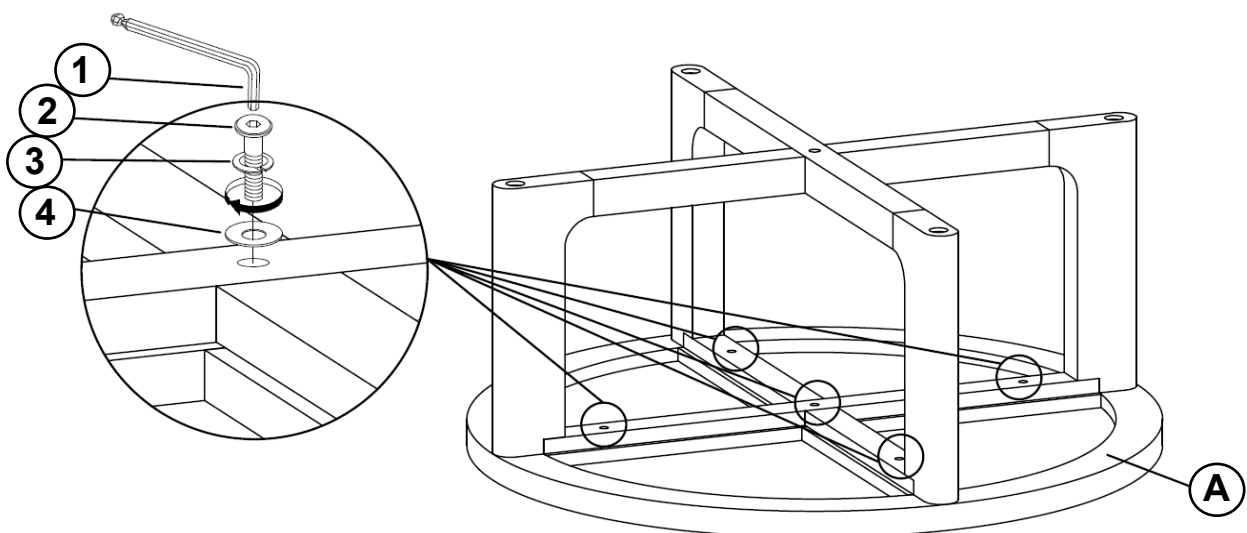

ITEM: **735998**

**ASSEMBLY INSTRUCTIONS**

**STEP 5**

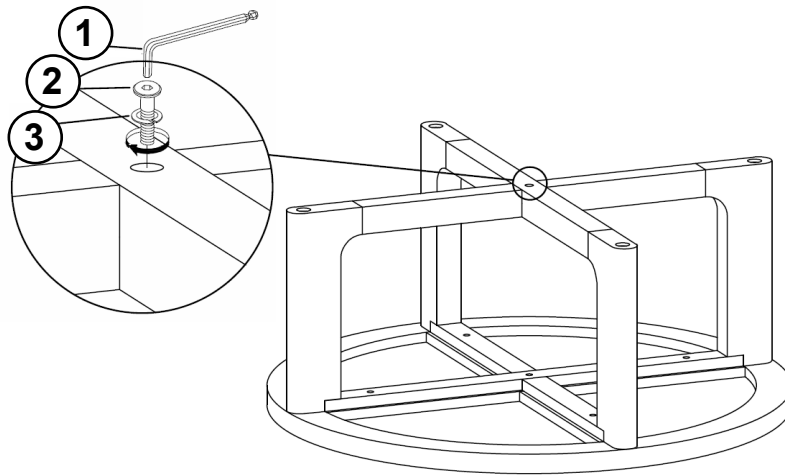

**STEP 6**

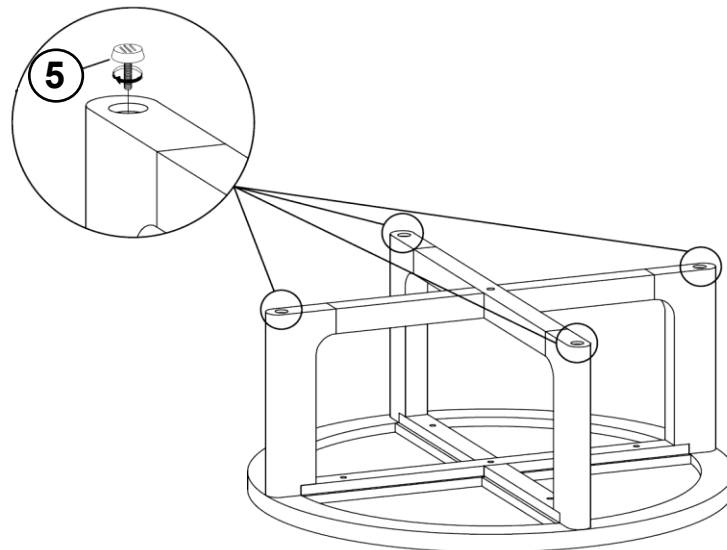

**STEP 7**  
**COMPLETE**

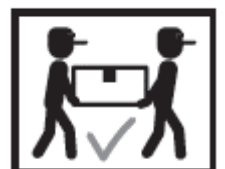
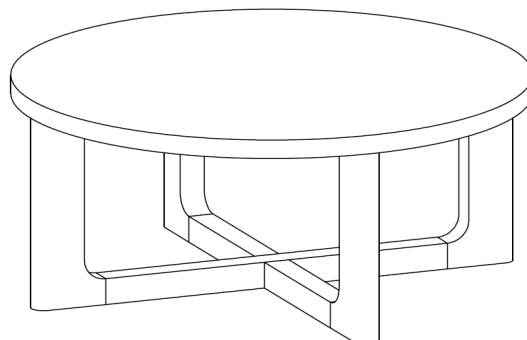

ITEM: 735998

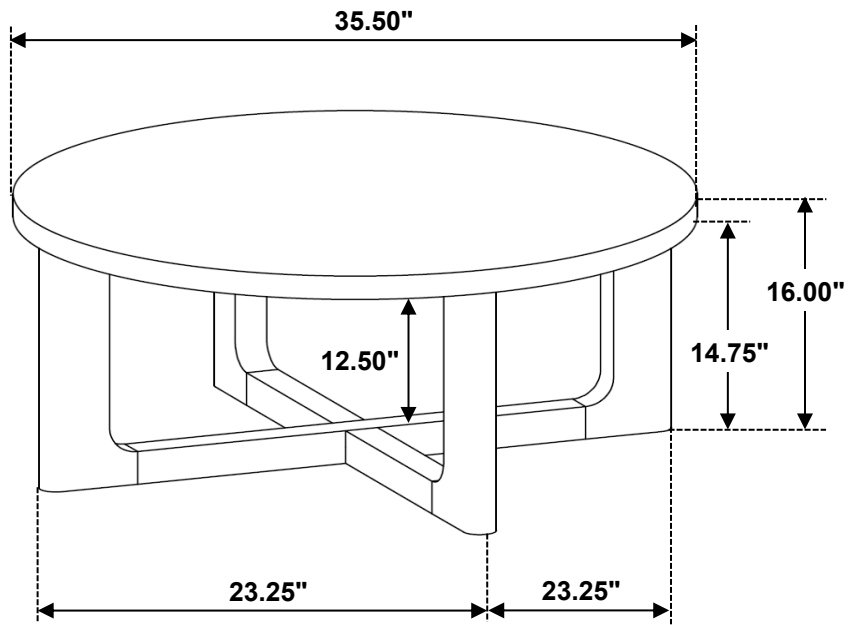

Note: Dimension tolerance  $\pm 5\%$