



ASSEMBLY INSTRUCTIONS

COASTER FINE FURNITURE



Fine Furniture for every stage of life

107286
Side Chair

REVISION 0 : 12/23/2016
REVISION 1 : 05/20/2019
REVISION 2 : 11/30/2019
REVISION 3 : 12/14/2019
REVISION 4 : 07/28/2022
REVISION 5 : 12/24/2024
REVISION 6 : 02/06/2025
REVISION 7 : 03/23/2026

ITEM: 107286



ASSEMBLY INSTRUCTIONS

ASSEMBLY TIPS:

1. Remove hardware from box and sort by size.
2. Please check to see that all hardware and parts are present prior to start of assembly.
3. Please follow attached instructions in the same sequence as numbered to assure fast & easy assembly.



WARNING!

1. Don't attempt to repair or modify parts that are broken or defective. Please contact the store immediately.
2. This product is for home use only and not intended for commercial establishments.







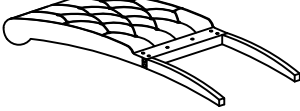
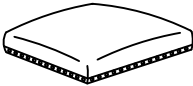
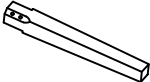

ASSEMBLY TIME

8 MINUTES

PARTS IDENTIFICATION

AM	BACK FRAME		1PC
BM	SEAT CUSHION WITH FRAME		1PC
CM	FRONT LEG		2PCS

HARDWARE IDENTIFICATION

1	SHORT BOLT (M6 x 40MM - RBW)		2PCS
2	MEDIUM BOLT (M6 x 60MM - RBW)		4PCS
3	LONG BOLT (M6 x 80MM - RBW)		4PCS
4	LOCK WASHER (M6 x 12MM - RBW)		10PCS
5	FLAT WASHER (M6 x 19MM - RBW)		10PCS
6	ALLEN WRENCH (M4 x 100MM - BLK)		1PC

NOTE:

Quantities shown are for one chair.

Phillips head screw driver is required in the assembly process; however, manufacturer does not provide this item.

ITEM: **107286**
ASSEMBLY INSTRUCTIONS

STEP 1

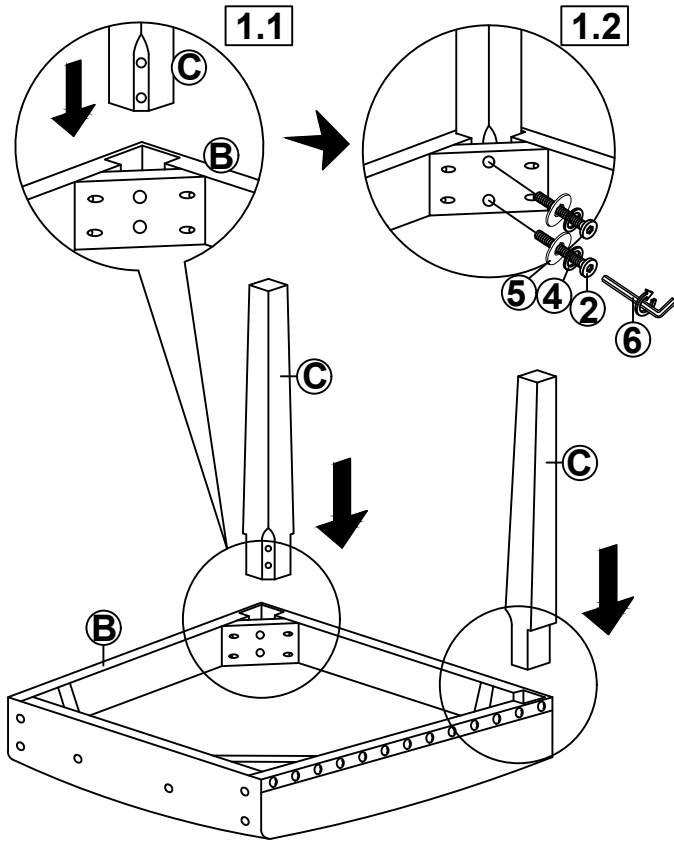

STEP 2

Do not fully tighten screws.

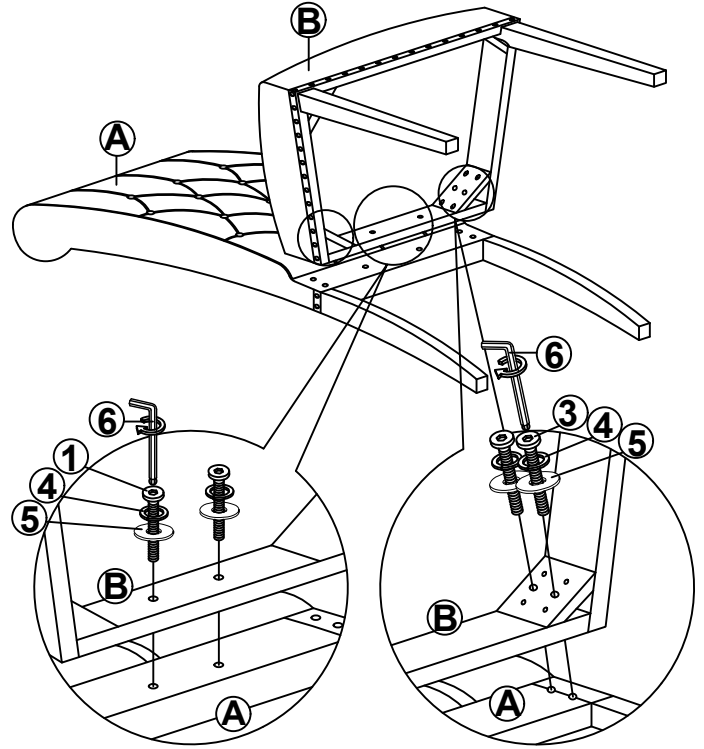

STEP 3

Place the chair on the flat surface and make sure the chair is level. Completely tighten the screws after Step 3.

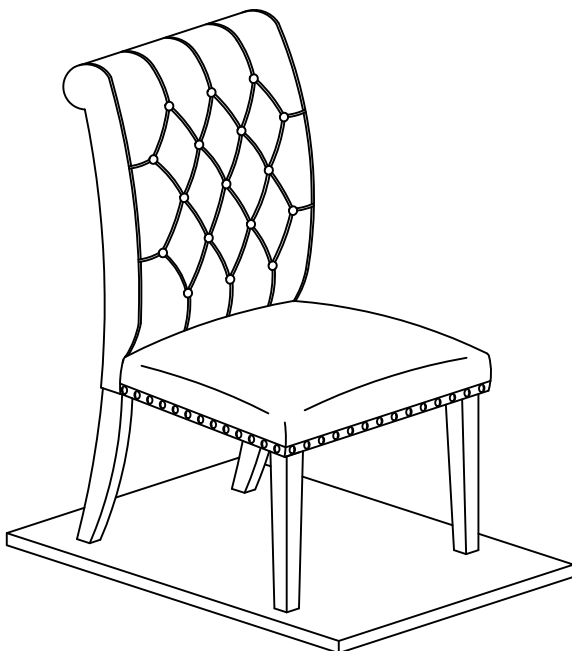

STEP 4

COMPLETE

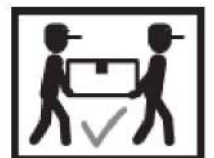
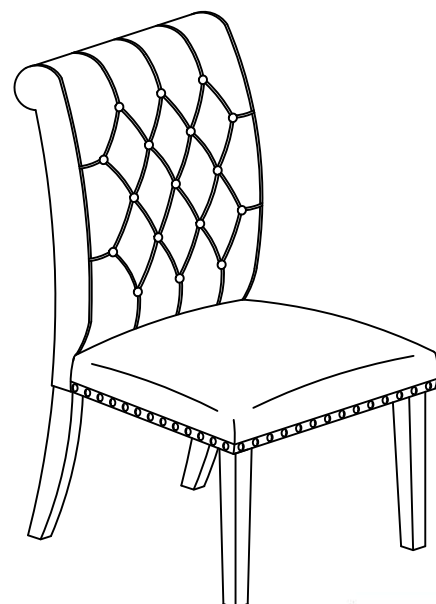

ITEM: **107286**

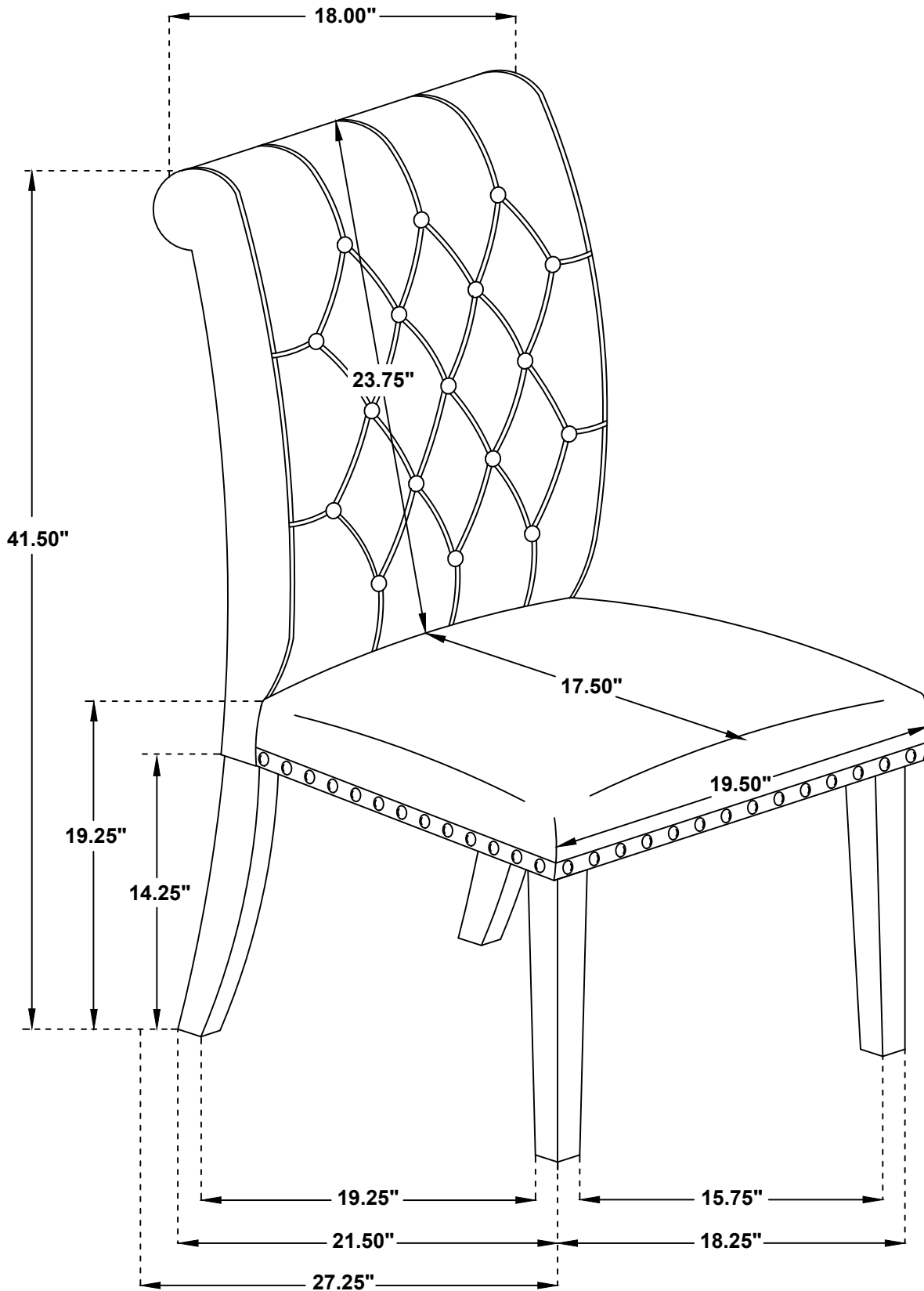

Note: Dimension tolerance $\pm 5\%$