

ASSEMBLY INSTRUCTIONS
COASTER FINE FURNITURE



Fine Furniture for every stage of life

801587 (B1&B2)
Writing Desk

ITEM: 801587 (B1&B2)



ASSEMBLY INSTRUCTIONS

ASSEMBLY TIPS:

1. Remove hardware from box and sort by size.
2. Please check to see that all hardware and parts are present prior to start of assembly.
3. Please follow attached instructions in the same sequence as numbered to assure fast & easy assembly.



WARNING!

1. Don't attempt to repair or modify parts that are broken or defective. Please contact the store immediately.
2. This product is for home use only and not intended for commercial establishments.







ASSEMBLY TIME

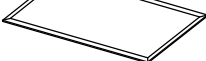
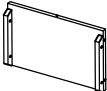

30 MINUTES

PARTS IDENTIFICATION

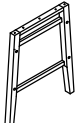
B1 (BOX 1)

A	DESK TOP		1PC
B	BACK PANEL		1PC
C	BOTTOM PANEL		1PC
D	SIDE PANEL		2PCS
E	CENTER TOP PANEL		1PC
F	LEG FRAME		2PCS

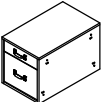
B2 (BOX 2)

G	LEFT DRAWER UNIT		1PC
H	RIGHT DRAWER UNIT		1PC
I	FLAT SUPPORT BAR		2PCS

ITEM: 801587 (B1&B2)



ASSEMBLY INSTRUCTIONS

ASSEMBLY TIPS:

1. Remove hardware from box and sort by size.
2. Please check to see that all hardware and parts are present prior to start of assembly.
3. Please follow attached instructions in the same sequence as numbered to assure fast & easy assembly.









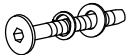
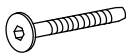

WARNING!

1. Don't attempt to repair or modify parts that are broken or defective. Please contact the store immediately.
2. This product is for home use only and not intended for commercial establishments.

HARDWARE IDENTIFICATION

Z-B1 (BOX 1) - HARDWARE PACK IS LOCATED IN 801587 (B1)

1	ALLEN WRENCH (M4 x 110mm - BLK)		1PC
2	SHORT BOLT WITH WASHER (M6 x 35mm - BLK)		6PCS
3	LONG BOLT WITH WASHER (M6 x 50mm - BLK)		10PCS
4	LONG BOLT (M6 x 50mm - BLK)		12PCS
5	WOOD DOWEL (M8 x 30mm)		30PCS
6	WOOD BUTTON (M14.3 x 9mm)		8PCS
7	CAM BOLT (T24 - BLK)		14PCS
8	CAM NUT (D15 x 9.5mm - BLK)		14PCS
9	CLIP		4PCS

NOTE:

Phillips head screw driver is required in the assembly process; however, manufacturer does not provide this item.

ITEM: **801587 (B1&B2)**



ASSEMBLY INSTRUCTIONS

STEP 1

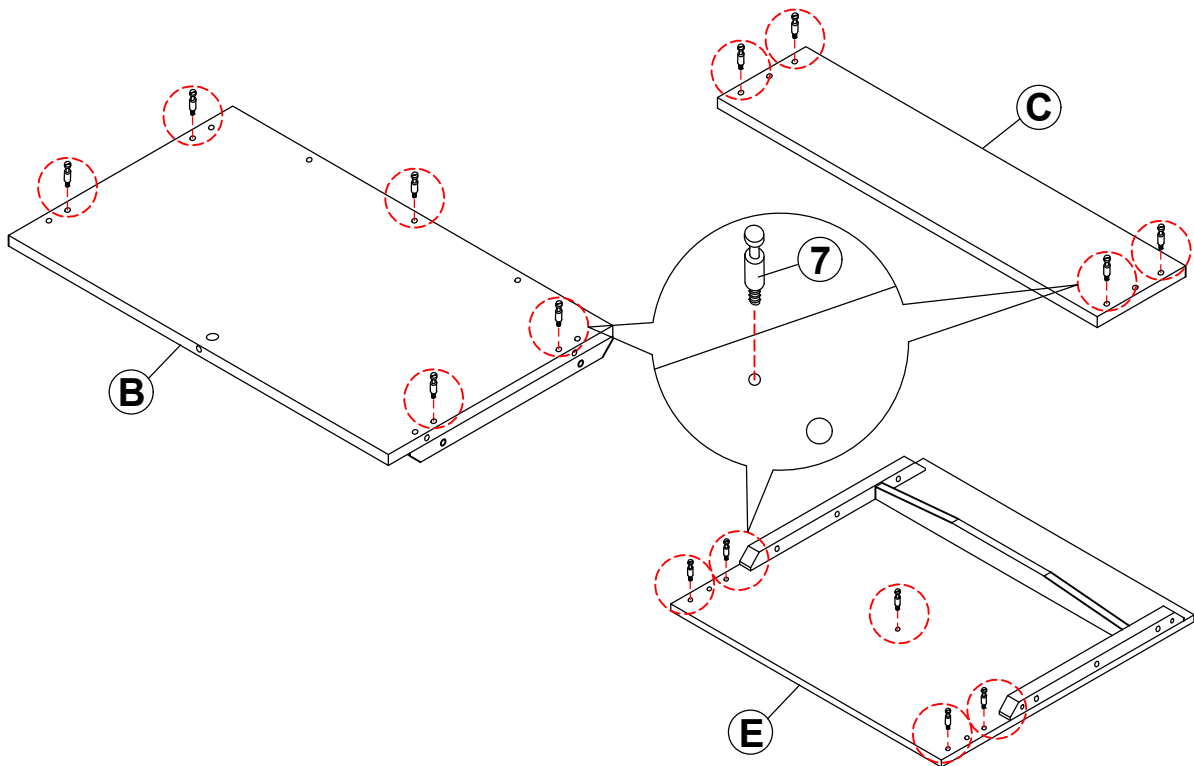

STEP 2

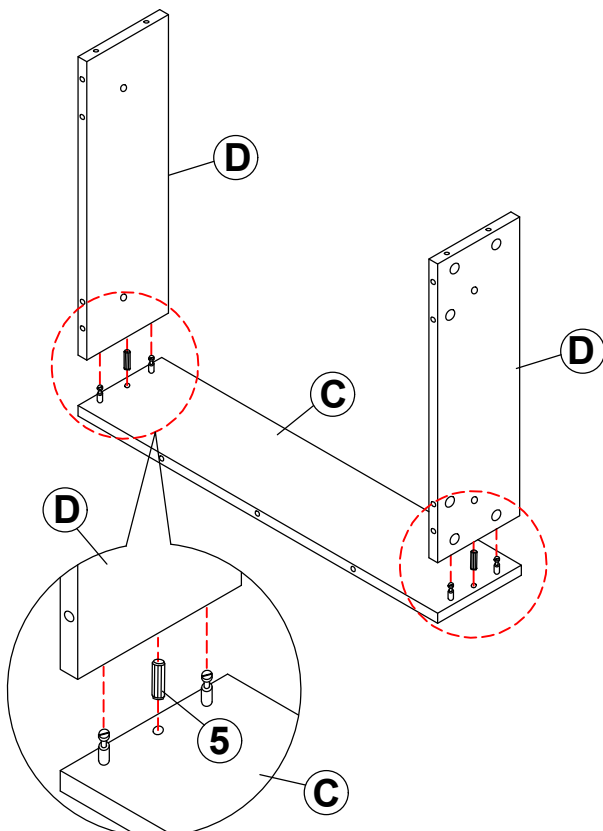

STEP 3

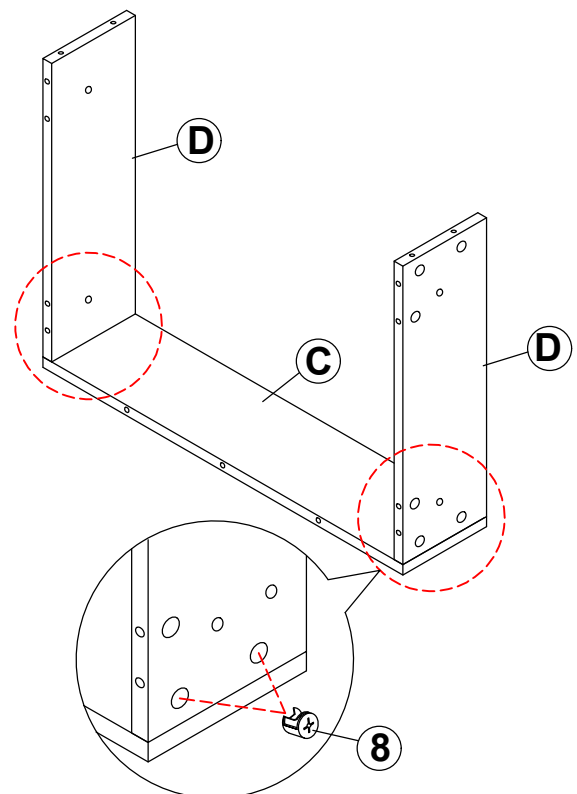

ITEM: **801587 (B1&B2)**



ASSEMBLY INSTRUCTIONS

STEP 4

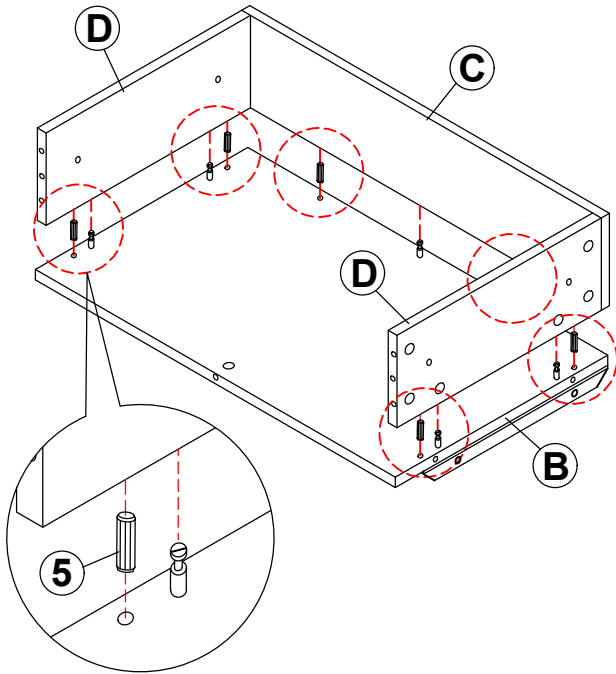

STEP 5

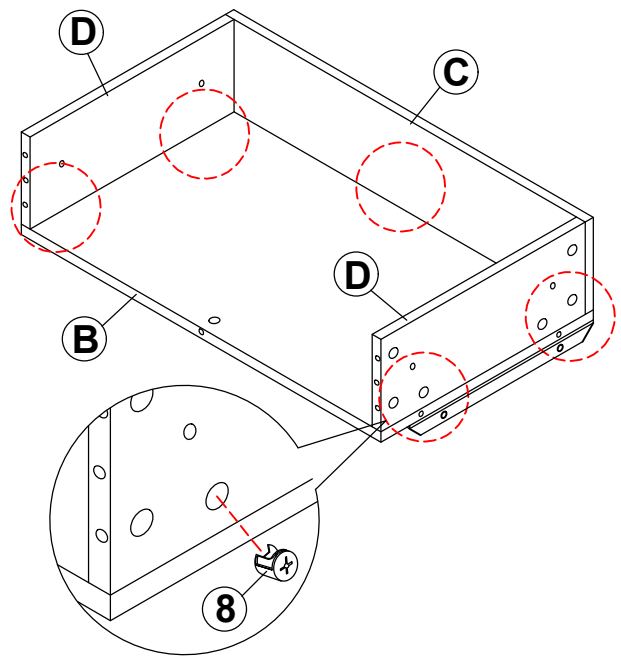

STEP 6

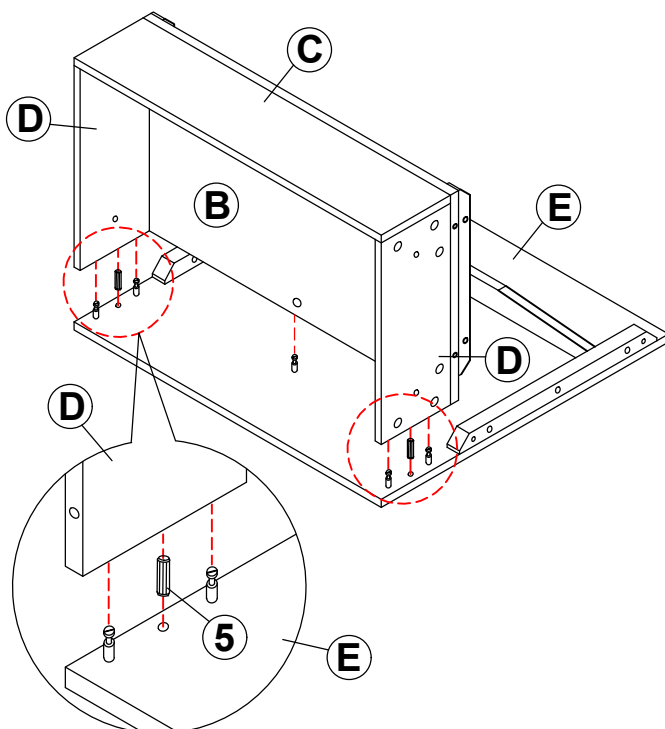

STEP 7

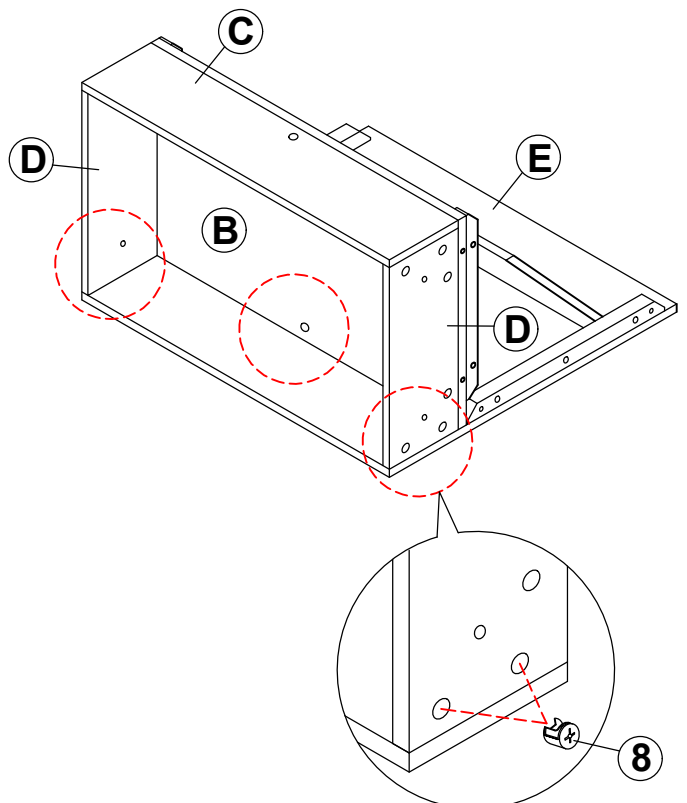

ITEM: **801587 (B1&B2)**



ASSEMBLY INSTRUCTIONS

STEP 8

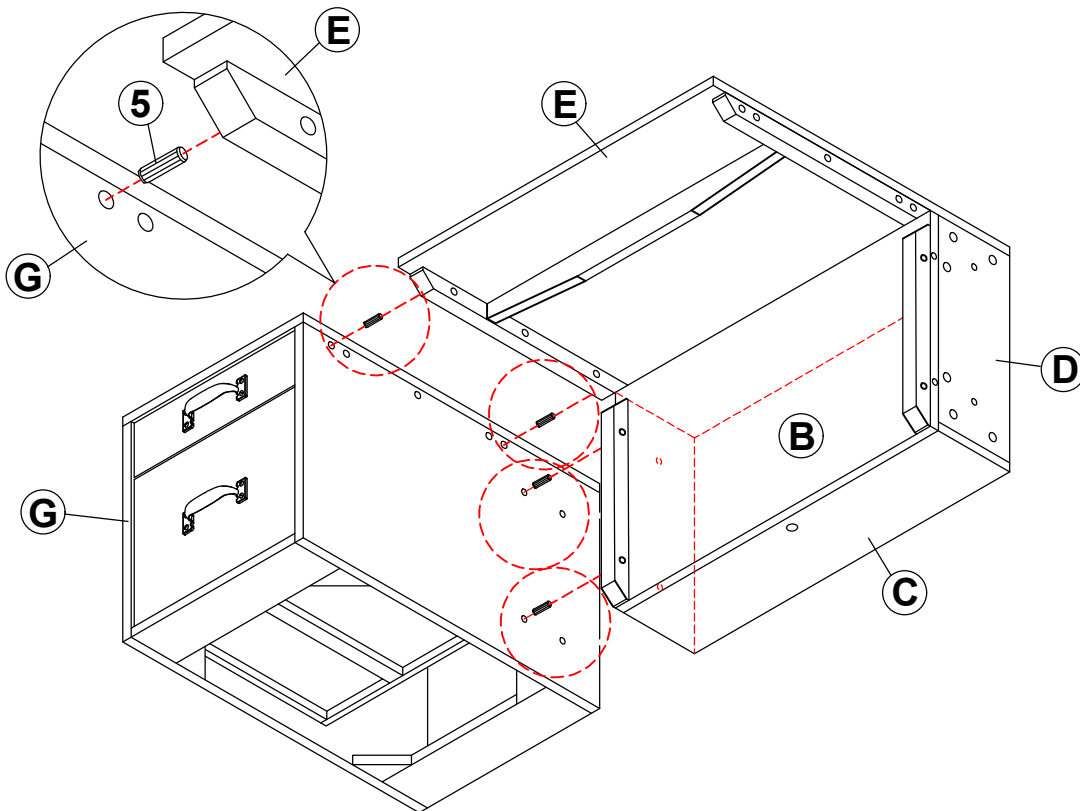

STEP 9

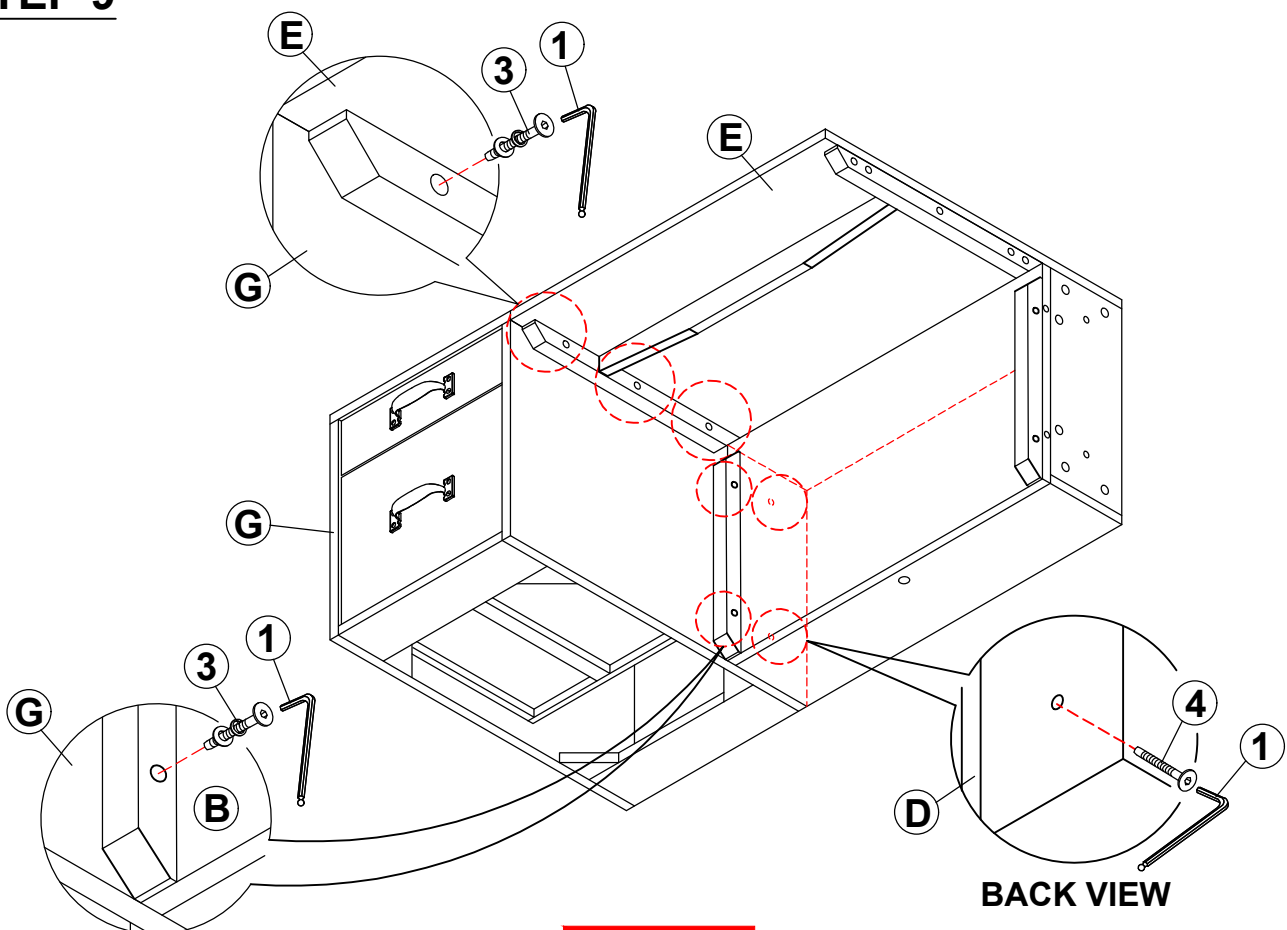

ITEM: **801587 (B1&B2)**



ASSEMBLY INSTRUCTIONS

STEP 10

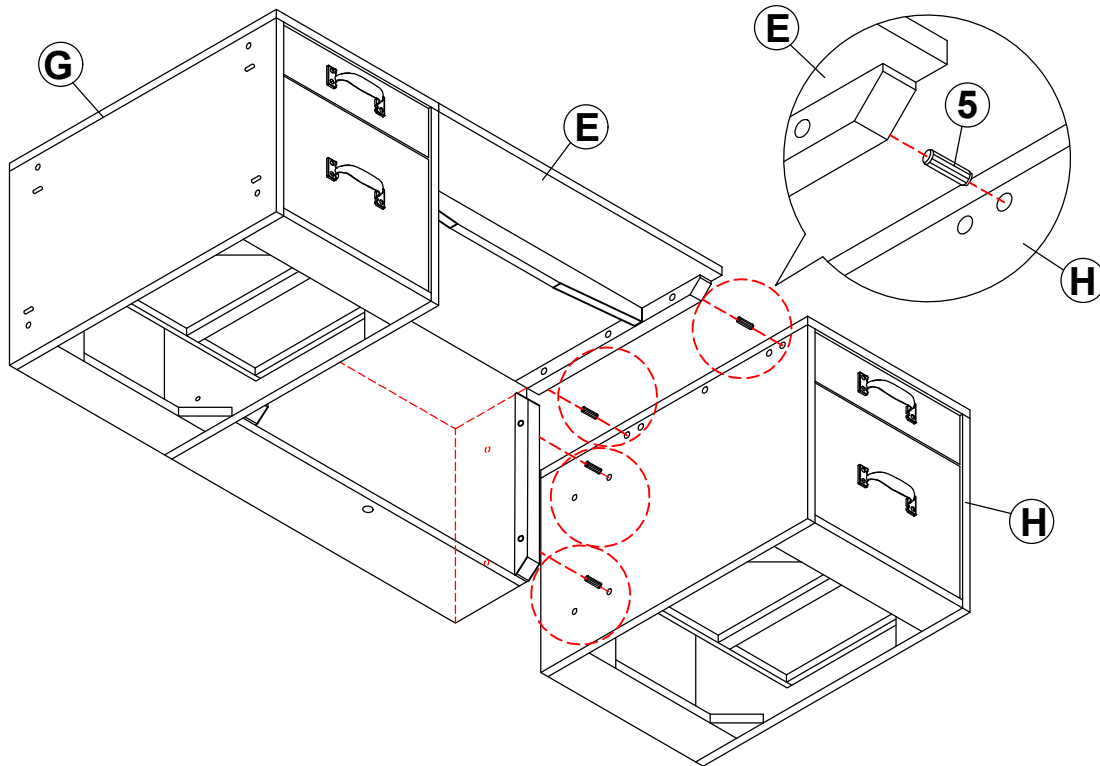

STEP 11

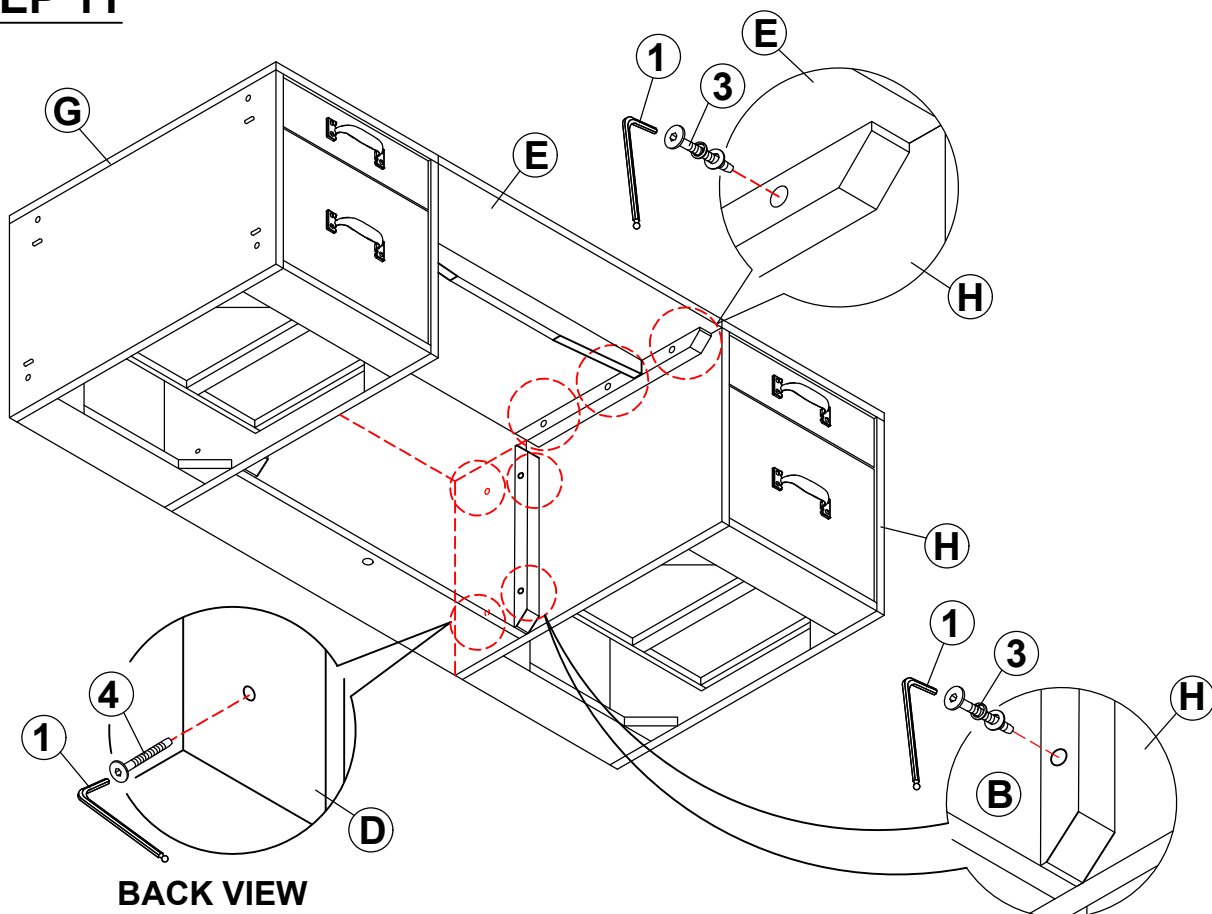

ITEM: **801587 (B1&B2)**



ASSEMBLY INSTRUCTIONS

STEP 12

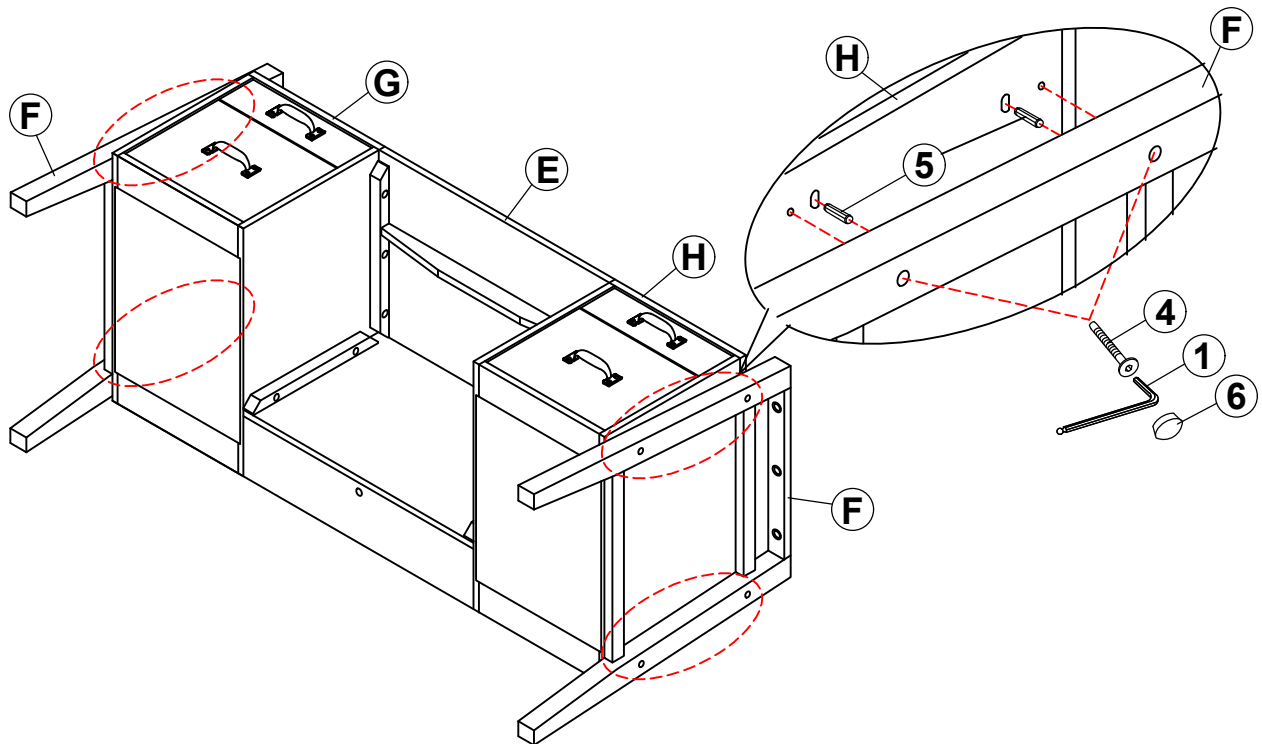

STEP 13

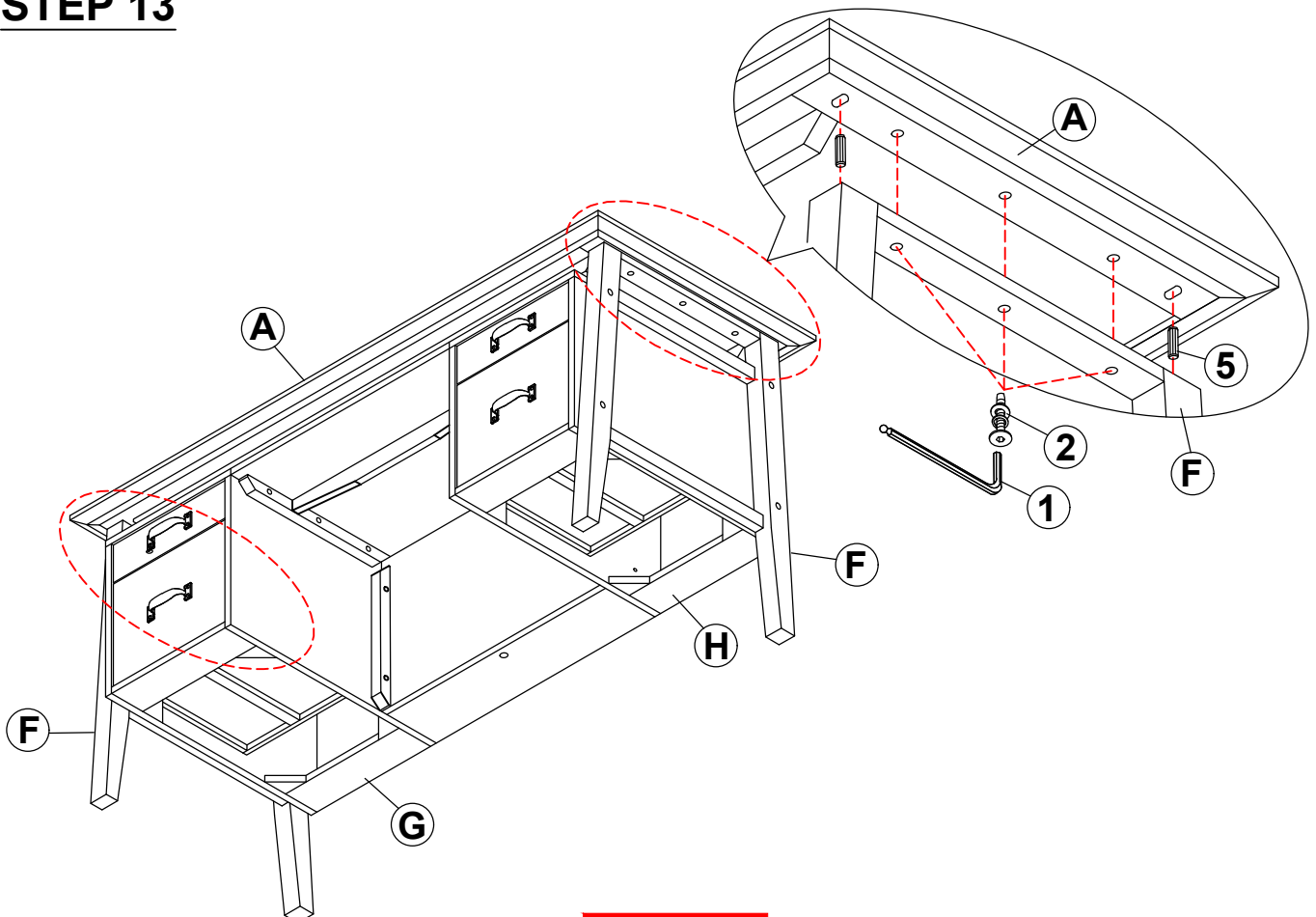

ITEM: **801587 (B1&B2)**



ASSEMBLY INSTRUCTIONS

STEP 14

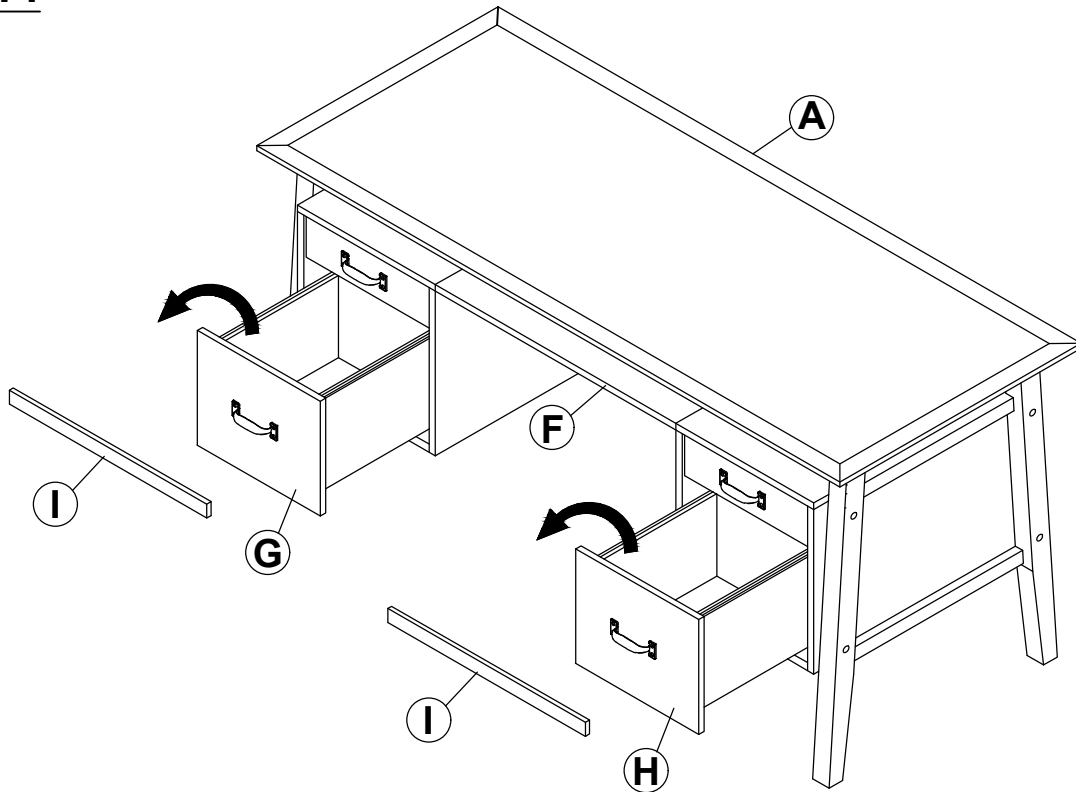

STEP 15

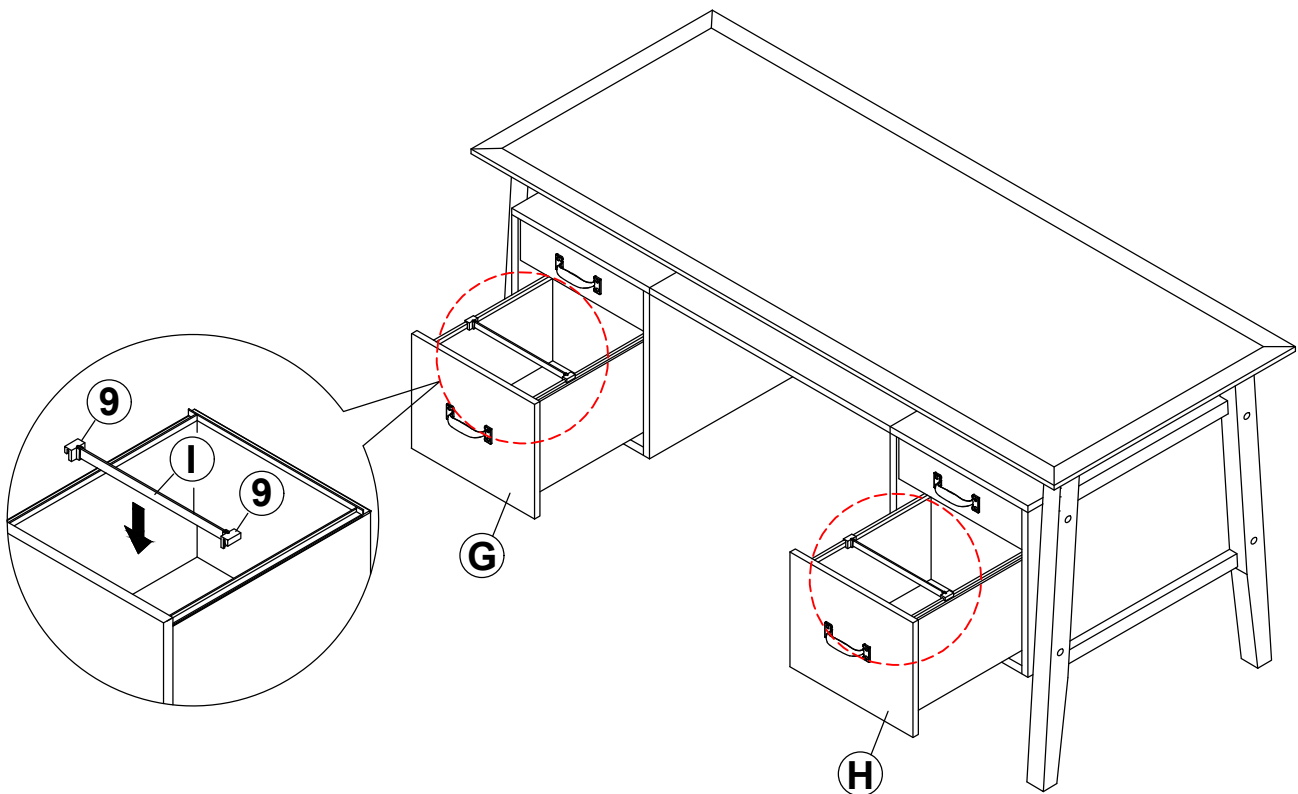

ITEM: **801587 (B1&B2)**



ASSEMBLY INSTRUCTIONS

STEP 16

COMPLETE

