

ASSEMBLY INSTRUCTIONS
COASTER FINE FURNITURE



Fine Furniture for every stage of life

183436N
Counter Chair

ITEM: 183436N

ASSEMBLY INSTRUCTIONS



ASSEMBLY TIPS:

1. Remove hardware from box and sort by size.
2. Please check to see that all hardware and parts are present prior to start of assembly.
3. Please follow attached instructions in the same sequence as numbered to assure fast & easy assembly.



WARNING!

1. Don't attempt to repair or modify parts that are broken or defective. Please contact the store immediately.
2. This product is for home use only and not intended for commercial establishments.



ASSEMBLY TIME

15 MINUTES

PARTS IDENTIFICATION

A BACK CUSHION

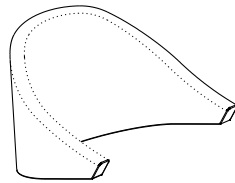

1PC

D BACK LEG

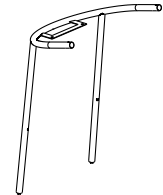

1PC

B SEAT CUSHION

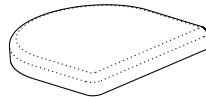

1PC

E CONNECTING TUBE

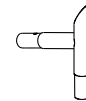

2PCS

C FRONT LEG

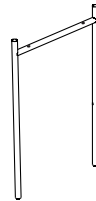

1PC

F FOOTREST

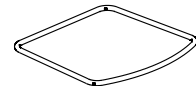

1PC

HARDWARE IDENTIFICATION

1 SHORT BOLT
(1/4" x 20mm - BLK)



6PCS

4 LOCK WASHER
(Ø1/4" - BLK)



2PCS

2 MEDIUM BOLT
(1/4" x 30mm - BLK)

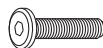

6PCS

5 FLAT WASHER
(Ø1/4" - BLK)



2PCS

3 LONG BOLT
(1/4" x 60mm - BLK)

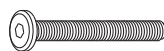

3PCS

6 ALLEN WRENCH
(4 x 26 x 60mm - BLK)



1PC

NOTE:

Quantities shown are for one chair.

Phillips head screw driver is required in the assembly process; however, manufacturer does not provide this item.

ITEM: 183436N

ASSEMBLY INSTRUCTIONS



STEP 1

Do not fully tighten all bolts until assembly is complete.

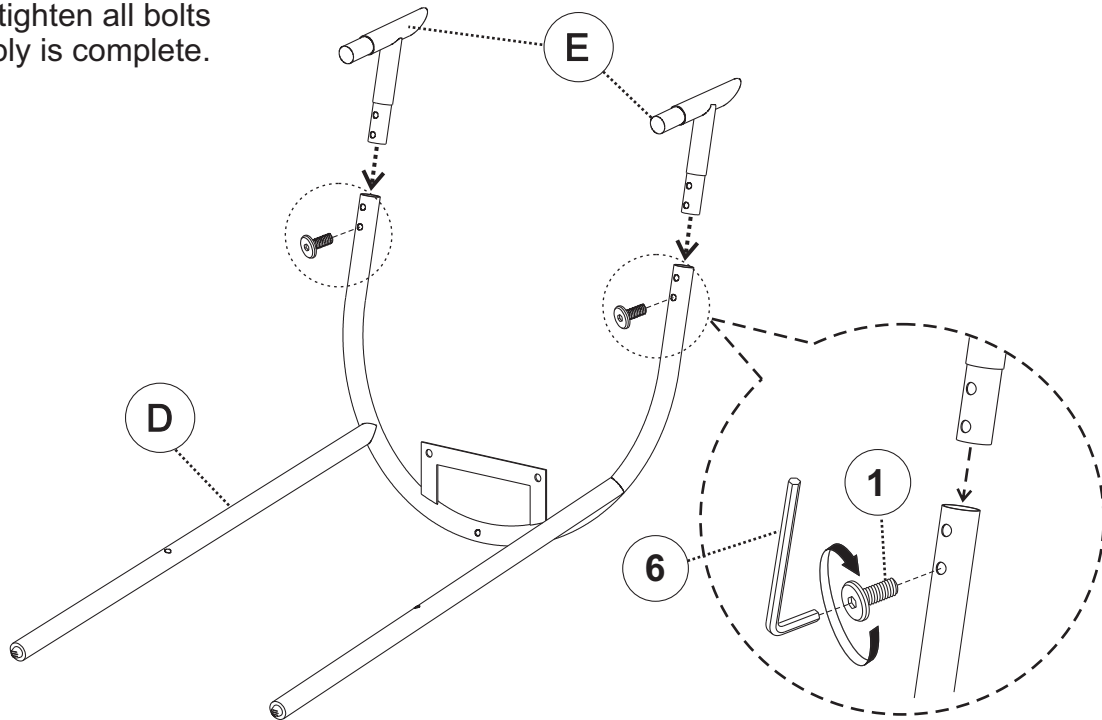

STEP 2

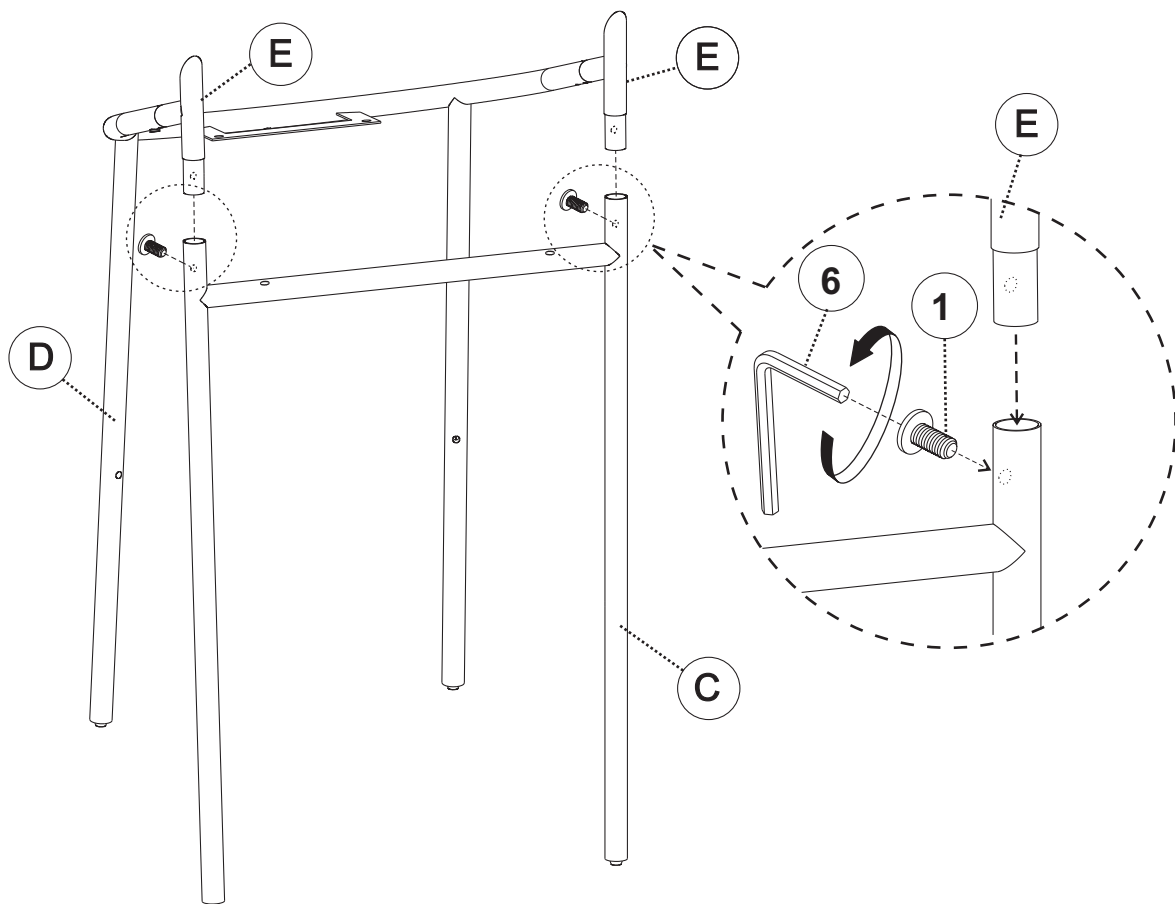

ITEM: **183436N**
ASSEMBLY INSTRUCTIONS
STEP 3

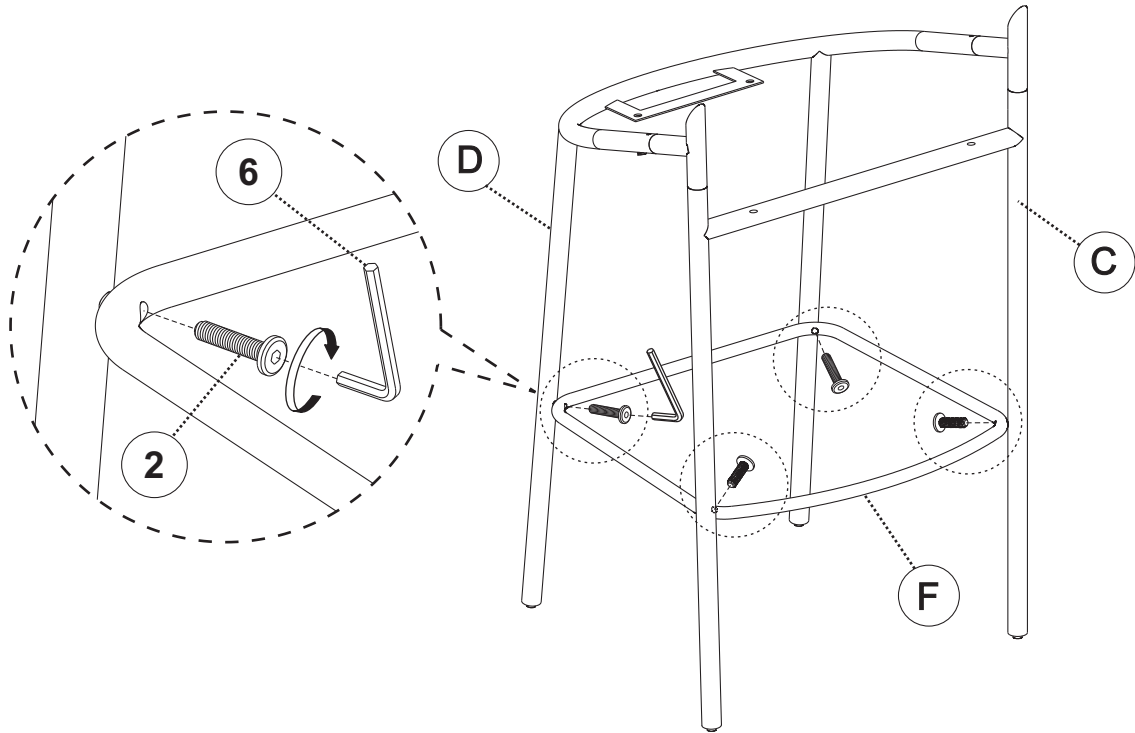

STEP 4

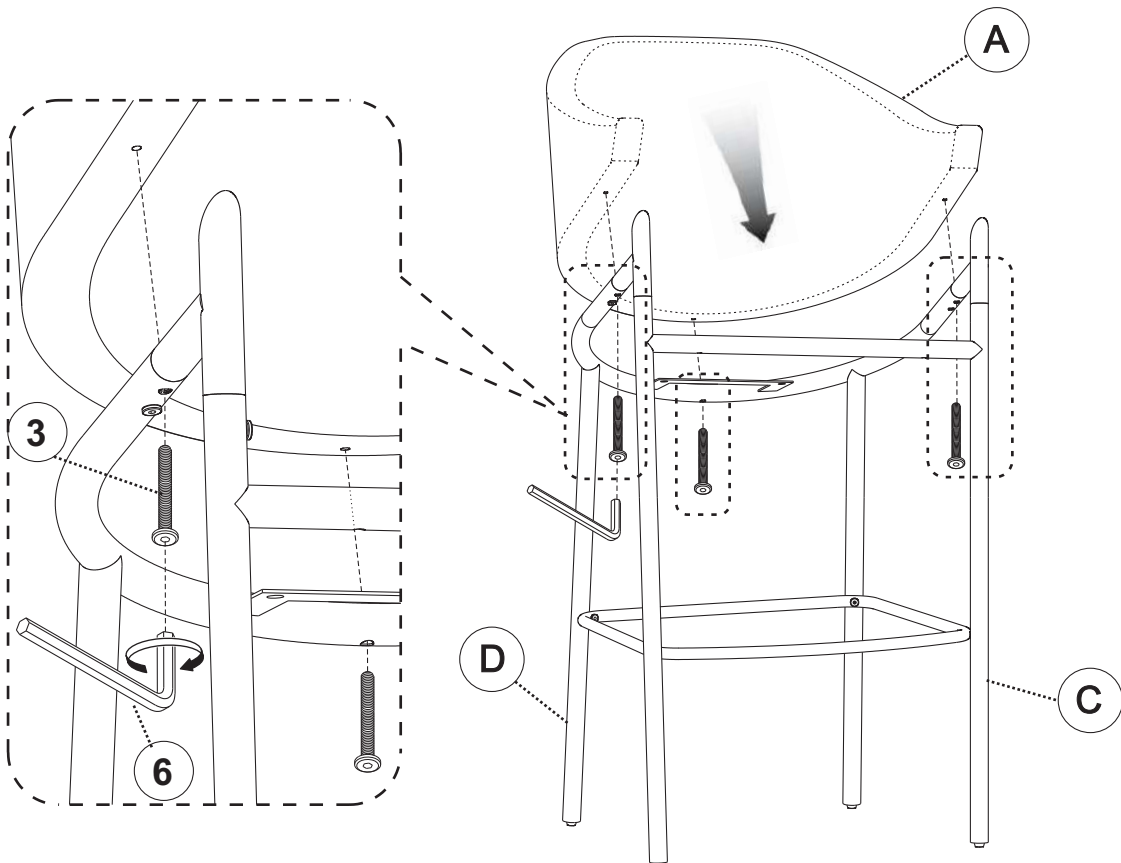

ITEM: **183436N**
ASSEMBLY INSTRUCTIONS

STEP 5

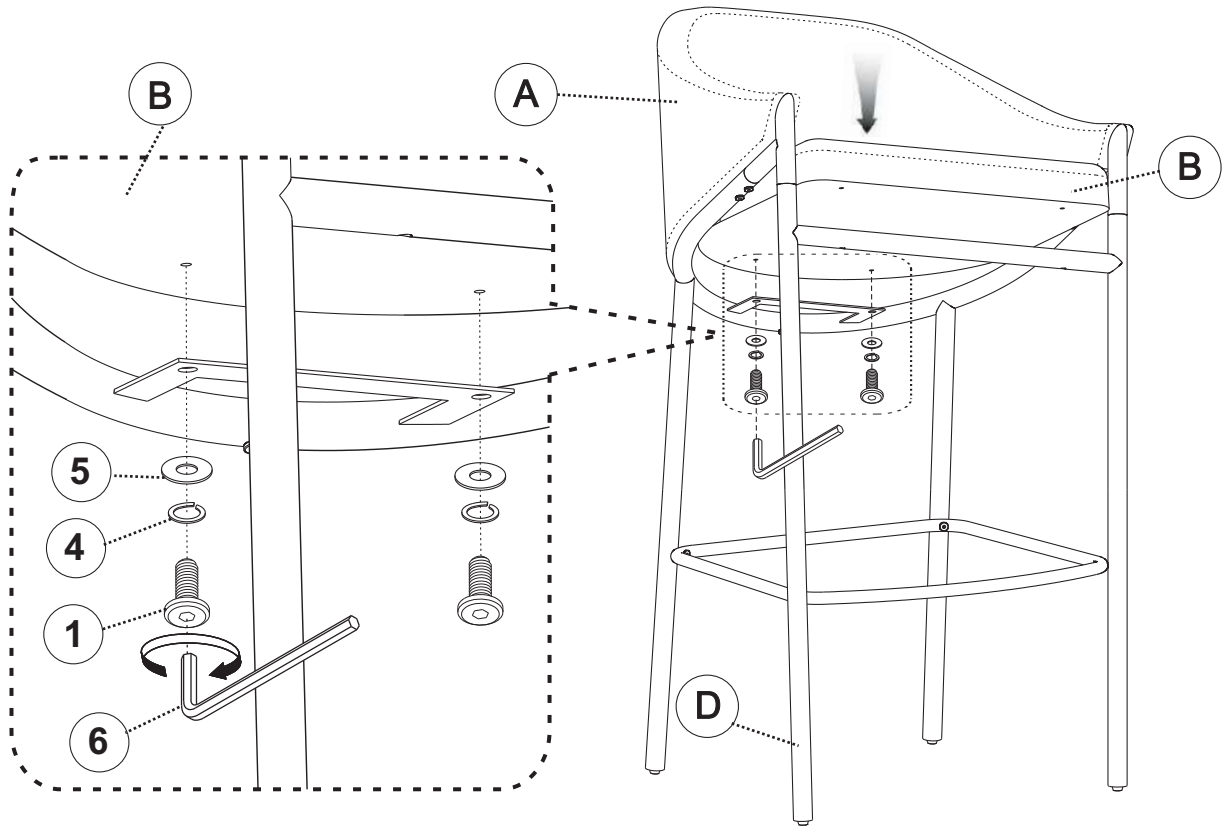

STEP 6

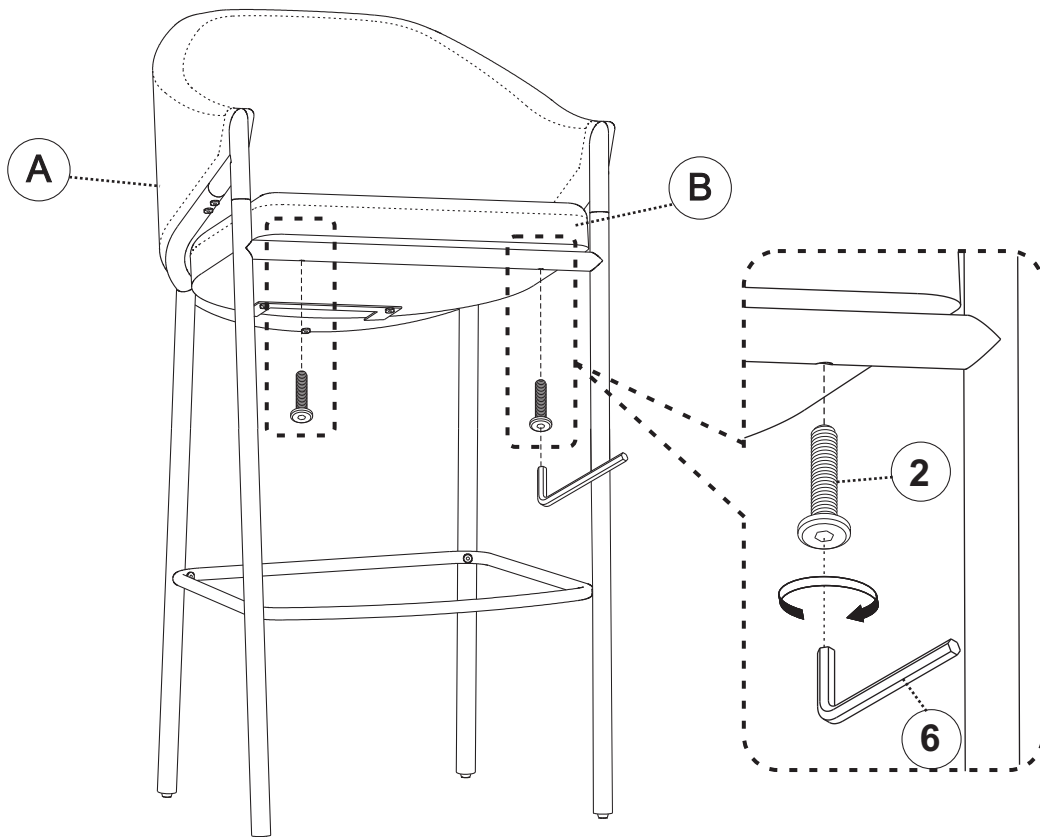

ITEM: **183436N**
ASSEMBLY INSTRUCTIONS



STEP 7
COMPLETE

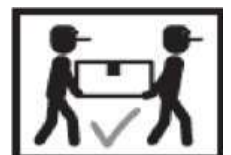
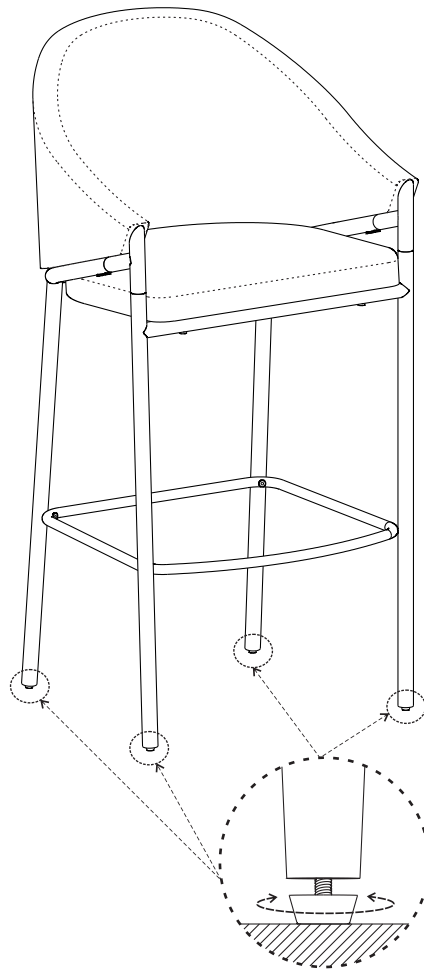

ITEM: 183436N

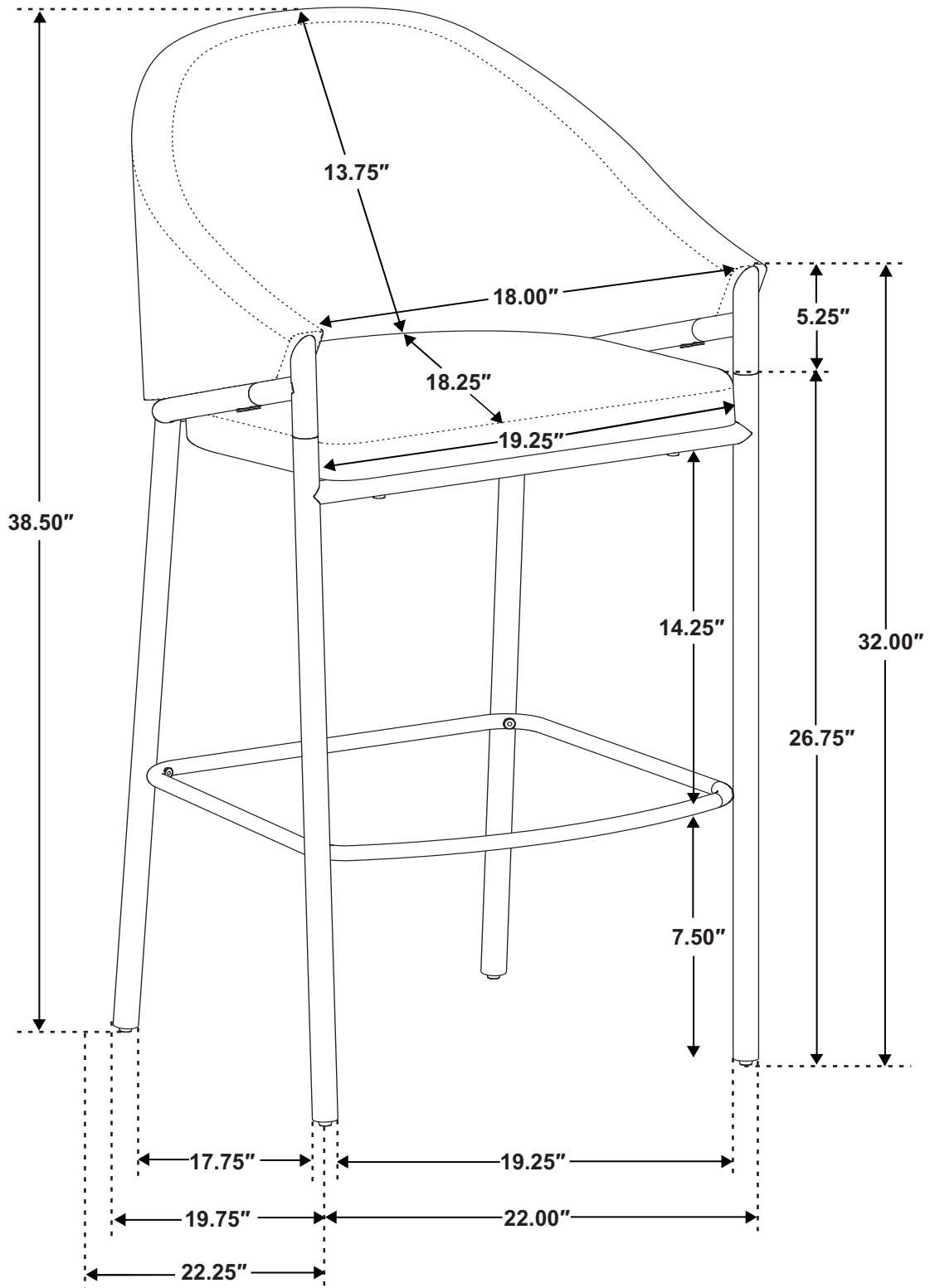

Note: Dimension tolerance $\pm 5\%$